

# SpotOn

The Audio Playout Software



[Introduction](#)

[Installation](#)

[Getting Started](#)

[Main Menus](#)

[Button Menus](#)

[Button Icons](#)

[Sound Card SetUp](#)

[GPI Interfaces](#)

[Additional Information](#)

[Versions](#)

© David Markie 24<sup>th</sup> January 2026

E-Mail - [david.markie@serialtech.com](mailto:david.markie@serialtech.com)

Web - [www.serialtech.com](http://www.serialtech.com)

# Contents

Introduction .....	4
Installation 1 .....	6
Getting Started.....	19
Main Menus .....	32
File Menu .....	33
SetUp Menu .....	52
Display Menu .....	71
Edit Menu.....	80
Search Menu .....	87
Global Menu.....	90
Options Menu .....	131
Info Menu.....	141
Engineering Menu.....	149
Admin Menu .....	174
Button Menus .....	204
Display Options .....	214
Audio SetUp .....	232
Audio SetUp - Gain.....	233
Audio SetUp -Trim.....	249
Audio SetUp - PlayList .....	280
Midi Assignment .....	284
Regions.....	288
Additional Information.....	291
Keyboard Shortcuts.....	292
Windows Sounds.....	295
Advanced Operation .....	299
USB Power Management .....	304
Game Port Connections .....	307
UDP/TCP Commands.....	310
PBus Control.....	322
Locked Attributes .....	325
Button Icons .....	327
Command Line Switches .....	333
Settings.....	335
XML Playout Logs .....	339
Screen Saver .....	341

Sound Card Mixers .....	344
Audio Processing .....	347
Decoders .....	350
Audio File Types .....	352
BLITS - 5.1 Surround Sound Ident .....	353
MultiChannel Sound .....	359
Sound Card SetUp .....	360
Audio Science ASI5041/2/4.....	361
DigiGram VX422 .....	377
Gina 3G.....	382
Layla3G.....	387
Edirol UA-101/UA-25 .....	391
M-Audio Delta 1010.....	397
RME HDSP AES-32 .....	406
RME SetUp .....	416
RME HDSP MADI .....	421
RME Fireface 800 .....	424
RME Multiface II.....	426
GPI Interfaces.....	429
Game Port Connections .....	430
GPI to Midi Convertor .....	433
Versions.....	456

# Introduction

SpotOn is a utility that can playout WAV, MP2, MP3, AIF and WMA format audio files from either touchscreen, keyboard, mouse or external trigger.

The main screen is shown below with the default setting of 64 buttons and 5 pages giving a total 320 buttons, initially all the buttons will be coloured dark green indicating an unassigned button.

Once loaded the button will change colour from green to blue and display the track name and duration, the colour and text can be changed later to something more appropriate.



Some of the main features of SpotOn:-

- Simple playout from mouse click or keyboard hot keys
- Audio output can be directed to any of the installed sound cards
- Customisable screen layout ranging from 1 to 160 buttons per page
- Button text and colour fully editable
- Audio gain, pan and speed adjustable
- Midi note input and output triggers available
- GPI input triggering
- Audio start and end points can be edited
- Buttons can be set to loop audio track
- Juke box style of playout with spacebar playing next track
- Fade In and Out options available

- Any number of tracks can be played simultaneously
- Uses WAV file Playlist data
- Comprehensive master/slave linking of buttons
- 5.1 surround sound capable
- ...

## [Installation](#)

# Installation 1

The SpotOn package is supplied in a single file:-

Setup.exe (Windows installer)

To install - insert the SpotOn CD into drive and the install process should begin automatically, if not navigate to the root directory of the CD drive and run the file Setup.exe

When installation is complete SpotOn will appear as a shortcut Icon on the Windows Desktop.



Use the Control Panel 'Add/Remove Programs' utility to remove or update the SpotOn package.



SpotOn requires an external security key (dongle) before it will run, see [activation](#) section for details.

The minimum requirements for running the application are:-

Operating System	Windows XP Professional recommended, Vista and
Installed RAM	1024MB
Software	Microsoft DirectX version 9
Sound Card/s	Fully Microsoft DirectSound compatible with WDM drivers

File types used by SpotOn

*.dta	Session data - binary
*.pkg	Package - binary
*.txt	Track List and logs - tab delimited text
*.csv	Track List - comma delimited text
*.blk	Button Block - binary
*.tcl	Timecode Trigger List- binary
*.ctp	Button colour template - binary
*.stf	Play Stack file - binary

SpotOn data folders under ..\Documents and Settings\All Users\Application Data\Serialtech\SpotOn\

BackUp	BackUp session files
Debug	Debug files
Event Logs	Daily logs of significant events for fault diagnosis (EventLog_ddmmyy.txt)
Local	Copies of audio files loaded from remote or removable drives
Playout Logs (text)	Daily logs of tracks played in plain text (PlayLog_ddmmyy.txt)
Playout Logs (XML)	Daily logs of tracks played in XML format (PlayLog_ddmmyy.xml)
Recent	Links to recently used audio files
Temp	Temporary files

SpotOn system files under ..\Documents and Settings\All Users\Application Data\Serialtech\SpotOn\

~temp.dta	Session saved/loaded when SpotOn exits/runs
BackUp\~backup_X.dta	BackUp sessions
BackUp\~statuslog_X.txt	Status log files
Recent\*.lnk	Recent file list

The above are default folder locations for the files, some folders can be changed via [Admin|File Folders](#) menu option.

SpotOn system folders under ..\Program Files\Serialtech\SpotOn\

Archive	Previous version of SpotOn
Web	Web server files
Images	Sample button image files
TestFiles	Test files - sine wave tones, silence and sample frequency tests

## Folder Access Rights

In some installations the Windows user account is based on a 'Restricted User' profile and this will not allow sufficient access rights to the Application Data folder. SpotOn will make an attempt at testing the access rights and show an error box if it detects a problem.

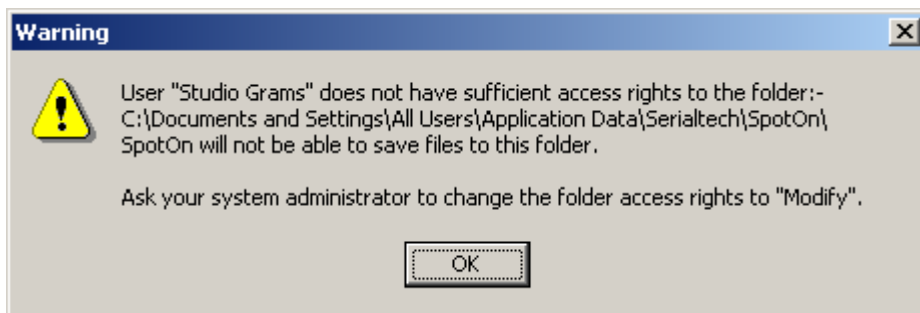

To set the access rights for the SpotOn Application Data folders: -

- 1, log on as Administrator
- 2, in Windows Explorer navigate to ..\Documents and Settings\All Users\Application Data\Serialtech\SpotOn\
  - 3, if the Application Data folder is hidden use the Windows Explorer menu item 'Tools|Folder Options|View|Show Hidden Files and Folders'
  - 4, in Windows Explorer uncheck menu item 'Use simple file sharing...'  
usually found at the bottom of the list

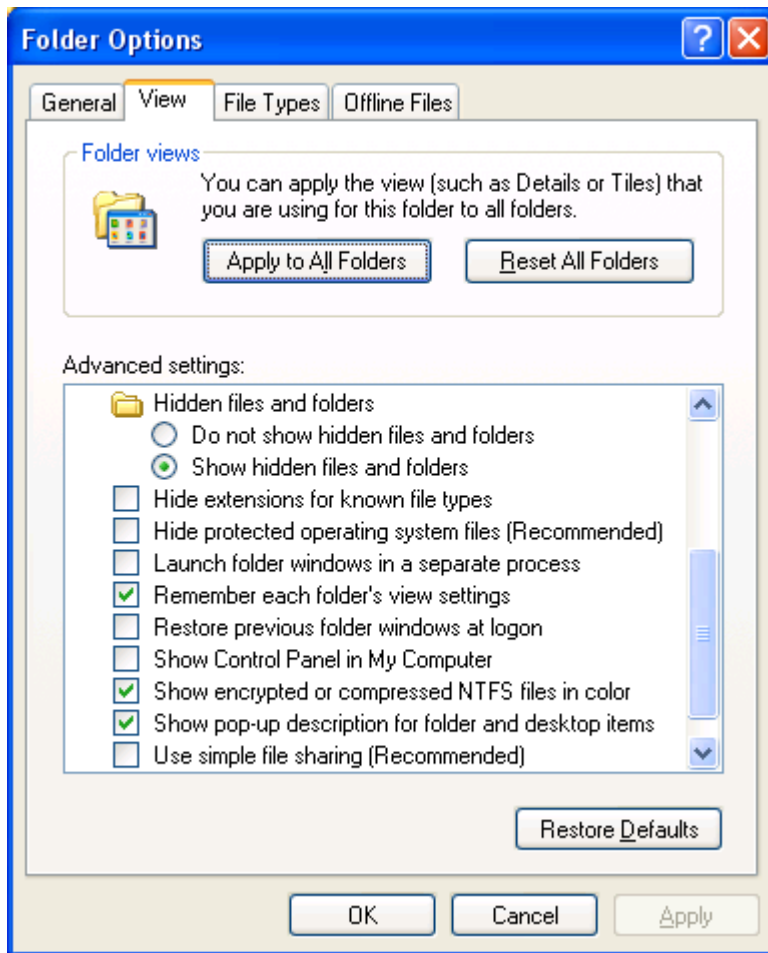

5, apply the changes

6, right-click in the right hand file pane of the folder display and select properties

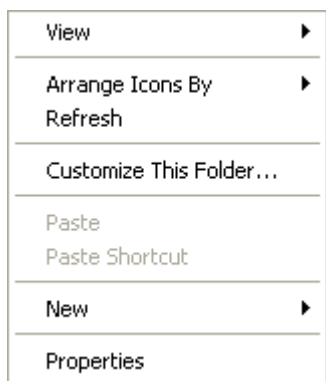

- 7, select the Security tab and the Administrator user, the permissions should be 'Full Control' as shown below

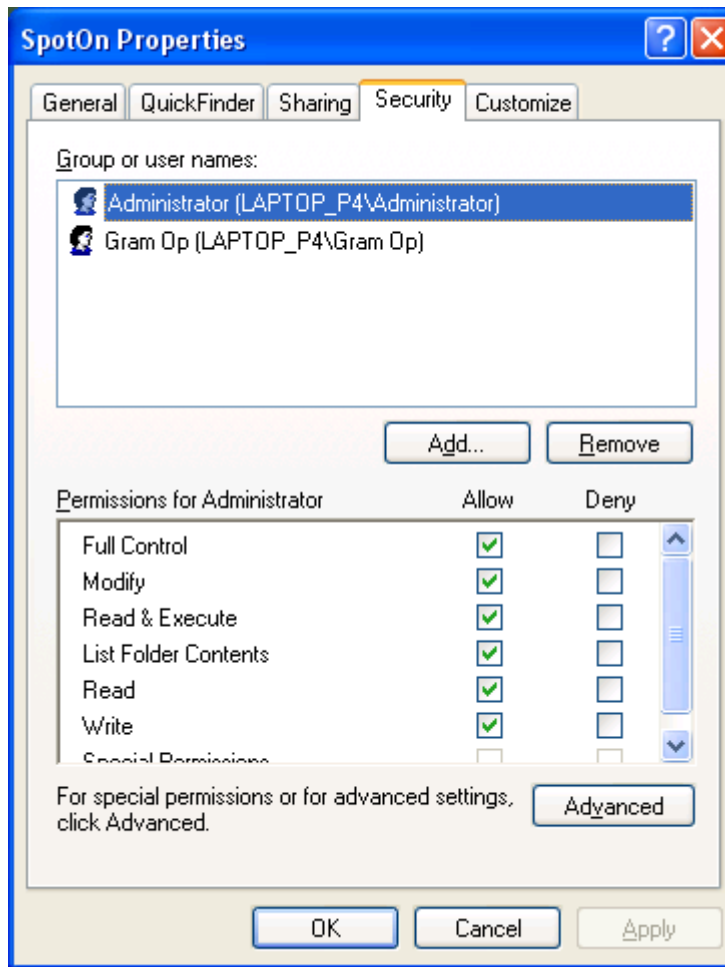

- 8, select the user that will be operating SpotOn, if the user account has been derived from a 'Restricted User' profile then the access rights will be as below, which does not grant Write permissions

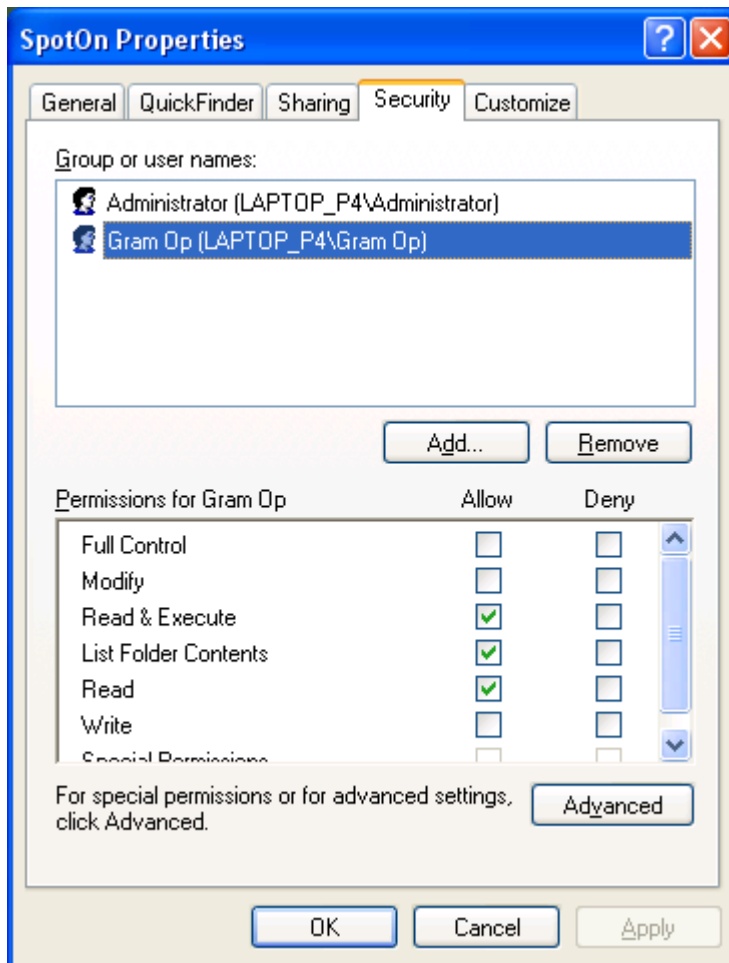

9, if necessary change the access rights by checking the 'Modify' checkbox to grant read/write access

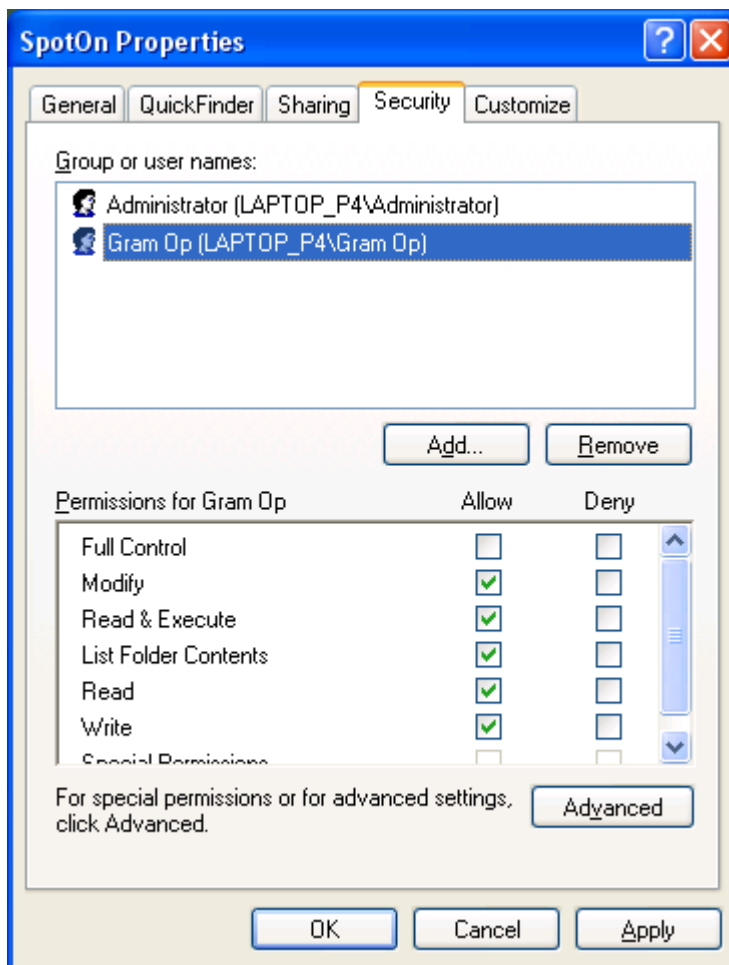

10, click on Apply to save changes

[Installation 2](#)

# Installation 2

## Sound Playback Preferred Device

When SpotOn is used on a single PC by several operators each with their own log-on, it is essential that the Sound Playback Preferred Device is the same for each user.

The Sound Playback Preferred Device is defined via the Windows Control Panel under the Sounds and Multimedia section.



Select the Audio tab

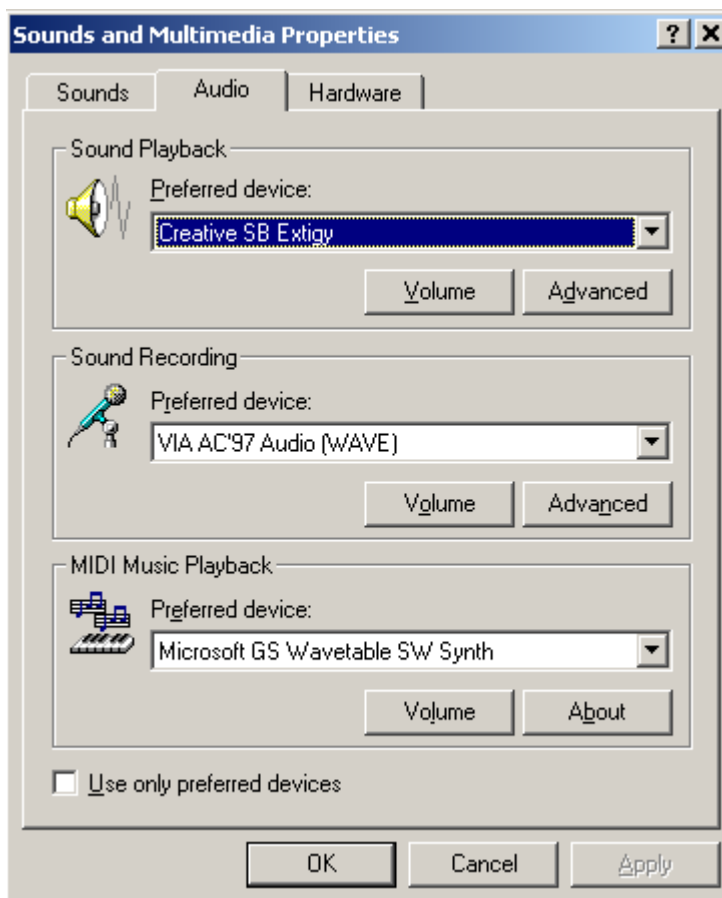

and then choose the required audio output device from the dropdown list

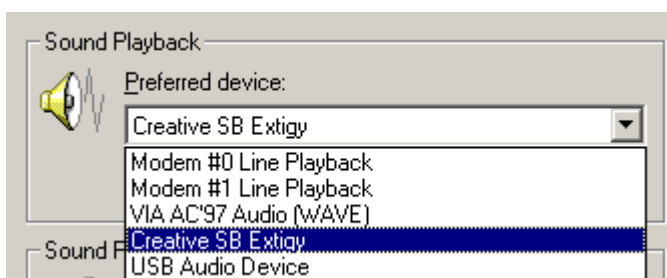

## Power Management

Windows XP computers have a sophisticated power management system that can get in the way of the SpotOn application, therefore it is recommended that the following settings be made.

In the Windows Control panel, select the Power Options icon and then the first tab named Power Schemes.

Choose the 'Always On' scheme, which should have the settings shown below with the Monitor powering down after an hour of inactivity and the hard disk continuously running and standby mode disabled

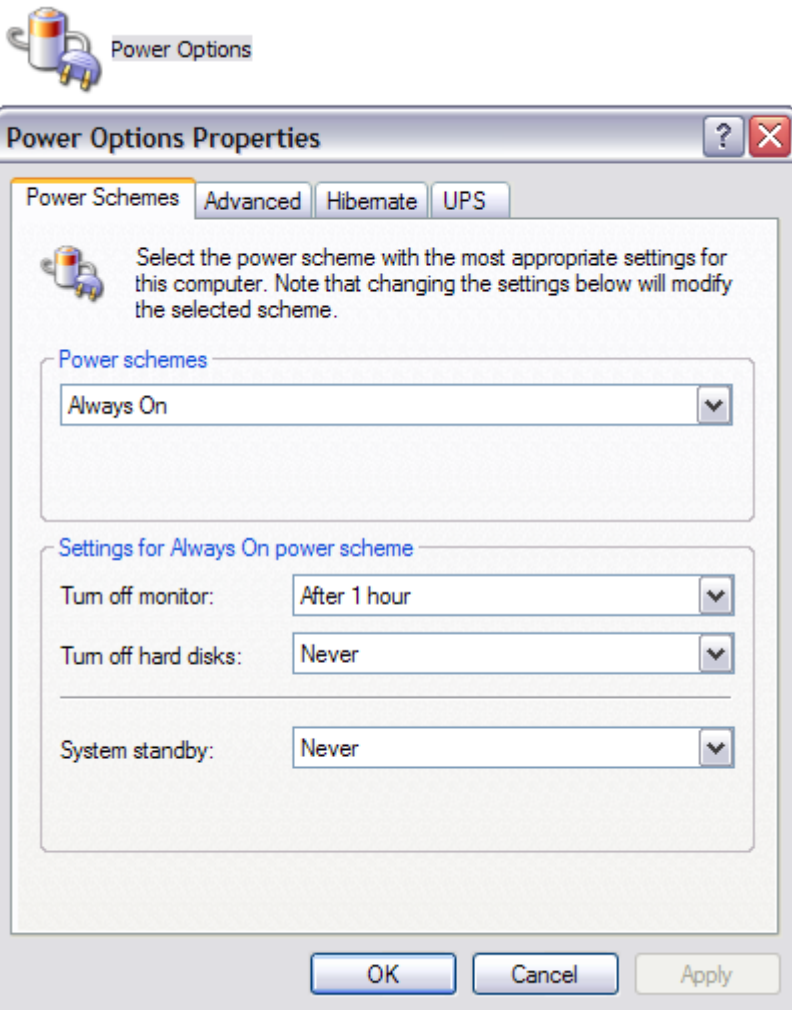

Also a very important setting to check can be found on the Hibernate tab, when running SpotOn the computer must not be allowed to enter its Hibernate mode, so the 'Enable Hibernation' option must be unchecked.

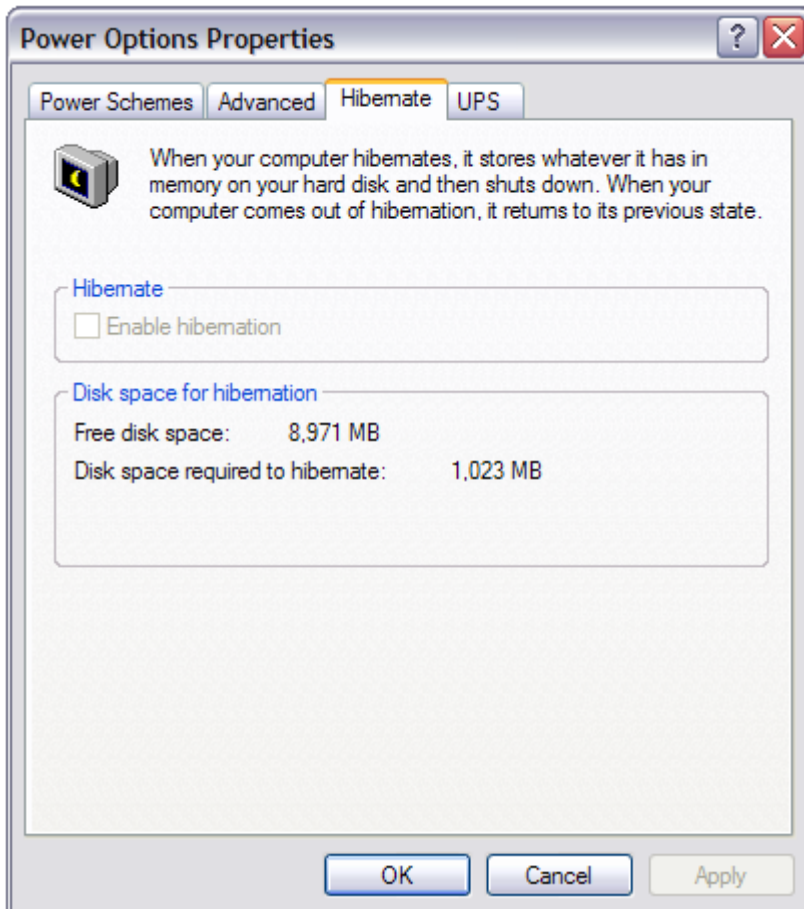

## CPU Usage

SpotOn does not require a large amount of CPU time, but it does require continued and regular amounts of CPU time in order to update the sound card buffers.

There are some programs that take more than their fair share of CPU time and these might cause problems when running with SpotOn, the effect would be gaps in the audio output.

However looking on the bright side, under tests SpotOn can play out tracks without problems whilst a virus scanner is checking the hard disk and using 97% of the CPU time cooperatively.

## Hard Disk Drives

As the audio information is read from continuously from disk, the speed or rather the seek time of the hard disk drive is important, therefore SCSI, fast IDE or SATA drives are recommended, large disk caches also boost performance. The audio data should preferably be stored on a non-system disk so separating the operating system from the data storage area. Regular defragmentation of the data storage disks will improve performance.

## Microsoft DirectX

The Microsoft Windows operating system has a subsection named DirectX, the utilities contained in this are concerned with MultiMedia functions.

DirectX is split into various sections such as DirectShow (graphics), DirectInput (game controllers) and DirectSound (audio), SpotOn makes extensive use of the DirectSound functions.

Within DirectSound are drivers to handle the interface to the hardware of the 'sound card', the most common type of interfaces are 'WAVE' and 'WDM' (Windows Device Model).

'WAVE' is based on old technology and could be regarded as a legacy interface, the more modern 'WDM' interface is the one that allows Microsoft DirectX/DirectSound full access to the sound card.

SpotOn relies on the 'WDM' interface to operate correctly.

So any sound card chosen to be used with SpotOn should show in the manufacturers data sheet references to full DirectX/DirectSound 'WDM' driver compatibility, if in doubt please contact the sound card manufacturer.

## Sound Cards

It is important that the sound card/s chosen should be fully compatible with the Microsoft DirectX/DirectSound API, consult the sound card manufacturers data for confirmation.

There is a wide choice of sound cards suitable for use with SpotOn as it make no great demands on the sound card performance.

Some sound cards which are aimed at the professional market may be unsuitable as they incorporate proprietary drivers that are not compatible with the Microsoft DirectX/DirectSound functions that SpotOn uses, these cards are often advertised with their own "virtual sound desk" software.

Another point to check when selecting a sound card is that it will allow several applications to use the sound card simultaneously, such as SpotOn being used for playout and a separate editing application preparing the audio files.

## Audio Sample Frequency

SpotOn uses an audio sampling frequency of 44.1kHz or 48kHz and consequently attempts to set up the sound card to run at this same frequency, however current versions of the Windows DirectX code take control of this away from the application. In some instances if another program changes the sound card sample frequency after SpotOn has been started, then this can make tracks played out via SpotOn appear at the wrong speed. See [Sound Card SetUp](#) for details of how the card sample frequency is set.

A much smaller frequency error is present in all sound cards, that is they are not clocked at precisely 44.1kHz or 48kHz the consequence of this is that over several minutes the timing of the audio track will slip relative to real time.

## Windows Volume Level Settings

At startup SpotOn will check the volume level settings of the audio outputs, if any of the settings (Master or Wave) are not 0dB then they will be reported in the dialog box shown below.



The levels can be reset to 0dB via the [Volume Controls](#) option in the Engineering menu, in the Admin menu is the option not to display the [Volume Level check](#) results.

## Update Check

If [Web Hyperlinks](#) are enabled SpotOn will attempt to check each week for new updates, if a new version is ready for download then a message dialog similar to the one shown below will appear.

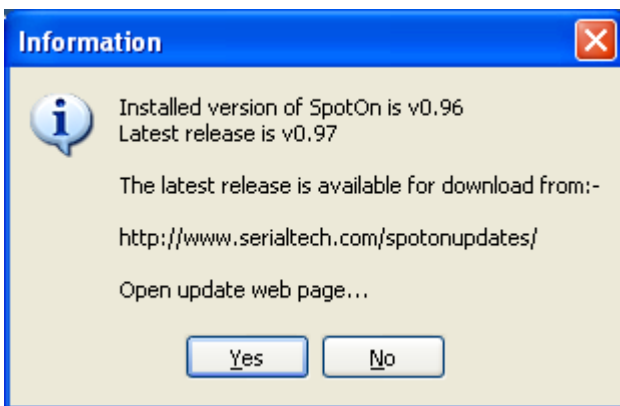

## Windows Vista and Windows 7

The latest version of Microsoft's operating system 'Windows 7' was released in 2009, SpotOn is compatible with Vista and Windows 7 but users should check that updated drivers for the sound card/s are available



# Activation

## Parallel/USB Port Security Key



SpotOn requires an external security key (dongle) before it will run, a key is supplied when the product is purchased.

The key plugs directly into the parallel printer port or a USB port on the PC, no user action is required to enable the key.

The parallel port key is designed to work with standard or bi-directional parallel ports and the latest 'intelligent' printers.

The program can be run on any PC which has the key fitted.

When using a USB key, note that Windows treats the same device in different USB ports (including hubs) as a different piece of hardware. This means that if the key has been set up on one port it should always be used in that port, otherwise Windows will report 'New Hardware Found' and start the hardware installation wizard.

When using a USB dongle the USB port power settings should be checked to ensure that the power is 'Always On' see [USB Power Management](#) for details.

The USB security keys along with many other devices are sensitive to discharges of static electricity. The USB ports on a PC can be used with memory sticks and external disc drives, the action of plugging in these devices can cause static discharges into the PC wiring. To avoid affecting the USB dongle with these discharges it is recommended that the USB security key is connected to a USB port that is isolated from other ports used for memory sticks.

# Getting Started 1

To load a track into an unassigned/blank button, right-click the button and select **Load** from the popup menu.

If the program options have been changed from their default settings, you may find that the popup menu is accessed by holding down the Shift key whilst right-clicking the button, see [Options|Mouse Function](#).

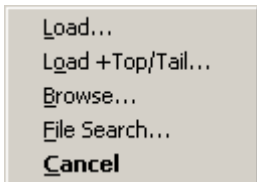

A standard file access dialog will appear listing common audio file types.

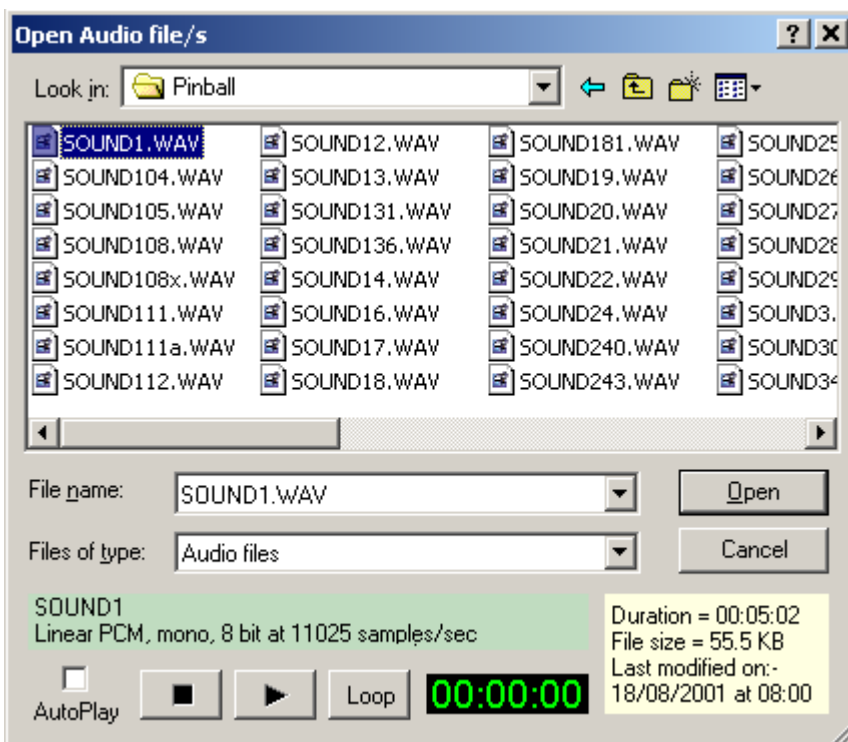

Navigate to the required file and click on Open, the file will then load into the button ready for use.

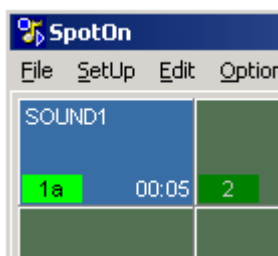

The track can be previewed before loading by using the controls at the bottom of the selection dialog, the track will be played out on the output assigned to be the [preview output](#).

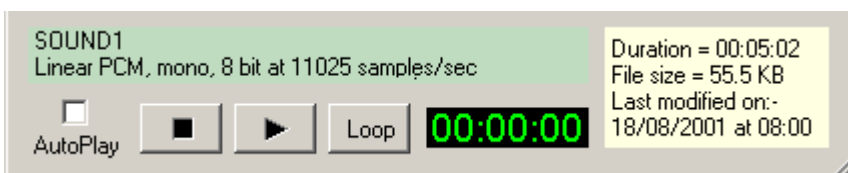

The filename or embedded description will be shown along with the track format and file details, the track can be played or looped.

The preview option is only available for linearly coded PCM WAV files, and files containing compressed data in MP3 or similar formats cannot be previewed at present.

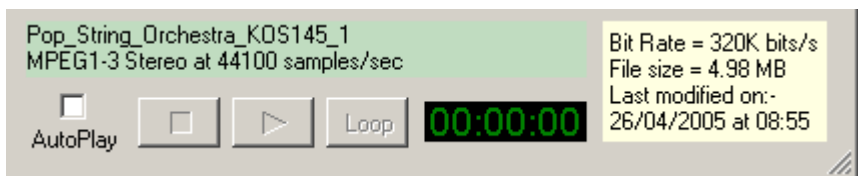
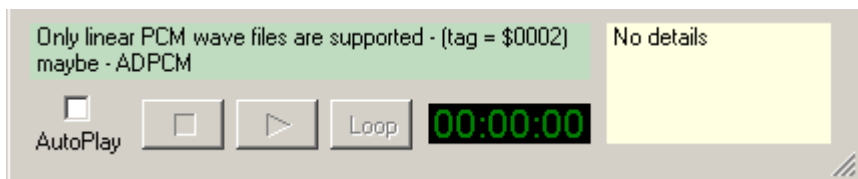

If the track preview section is not visible it can be enabled via the [Admin|Use WAV Preview](#) option

### AutoPlay

To speed up selection of the correct track the AutoPlay facility can be enabled



If AutoPlay is enabled then as soon as a valid WAV coded track is selected in the file list it will begin playing on the [preview output](#).

Once loaded the track can be played out by left-clicking on the button at which point the track number '1a' will change from black on green to yellow on red text. The time remaining (mm:ss) at the lower right of the button will count down as the playout progresses, at 00:03 the colour of this text will change to black on light blue.

Note - in the button legend '1a' - '1' refers to the button number and 'a' to the output device

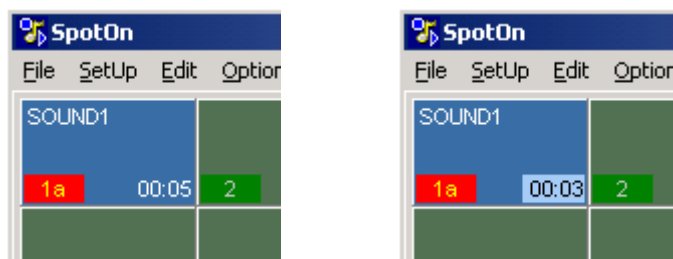

Repeated pressing of the left mouse button will alternately start and stop playout, when playout commences the track will always start from the beginning of the track. See [Options|MouseFunctions](#) for an alternative mode of operation.

[Getting Started 2](#)

## Getting Started 2

More than one track can be loaded into SpotOn by using the standard Windows multiple selection combinations of Shift+left-click for a block of tracks and Control+left-click for a non-contiguous list of tracks.

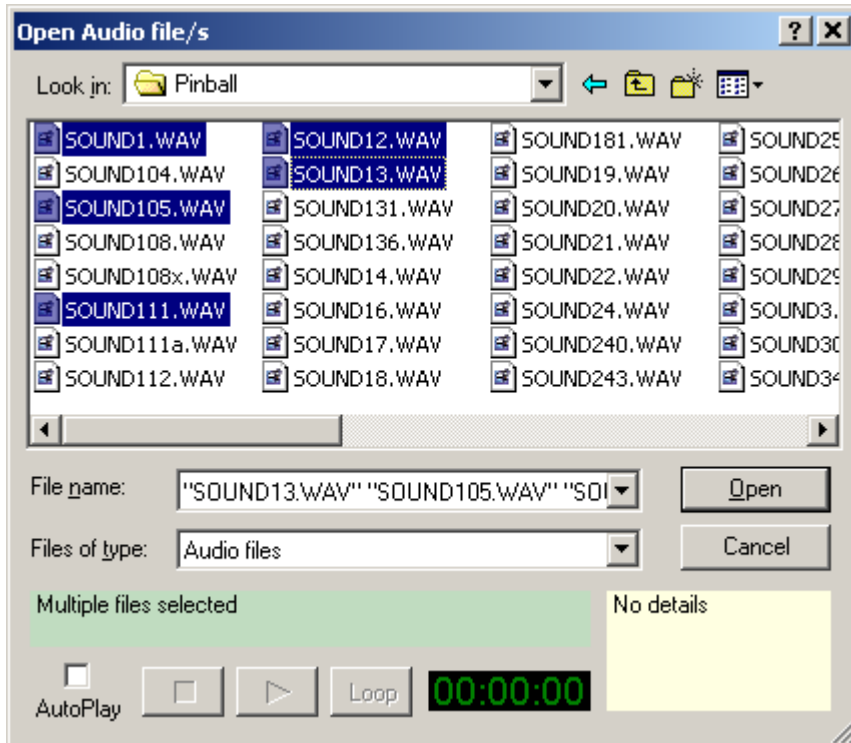
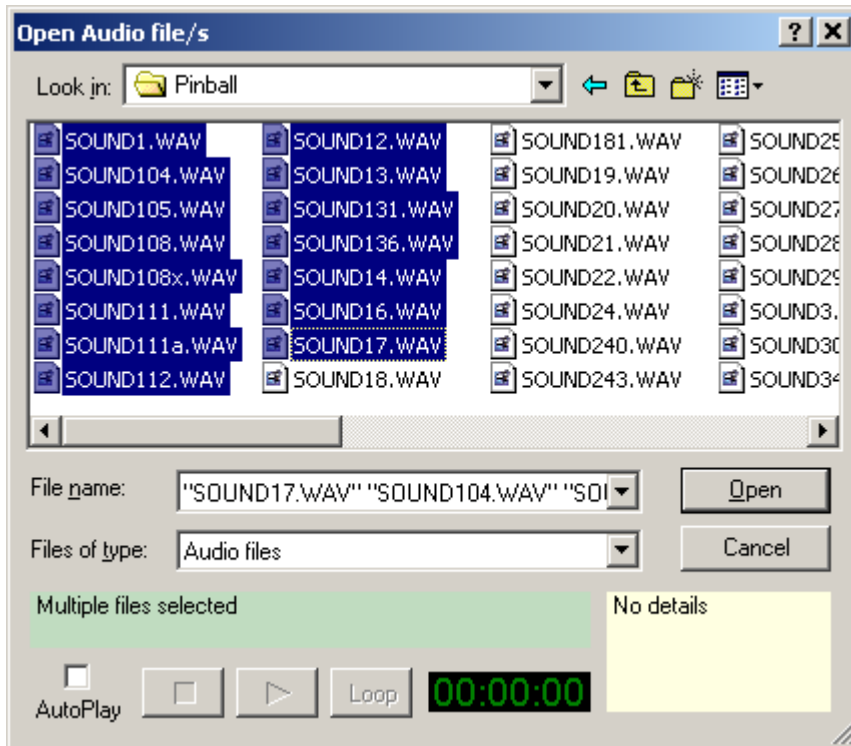

If the load action was started by right-clicking on button 1, the above Control click selection will result in the tracks being loaded into buttons as shown below.

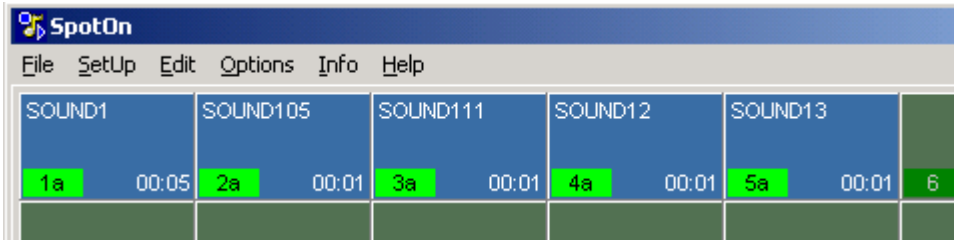

Note that due to the sorting of files by Windows the exact order of the files in SpotOn may not be the same as that seen in the file selection dialog box - SpotOn will sort them into alphabetical order.

As an alternative it is possible to drag and drop tracks onto buttons, to use this facility navigate to the required tracks using the **browse** option

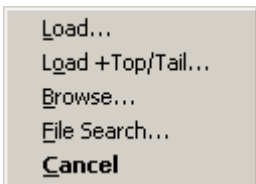

This will display a Windows Explorer navigation window.

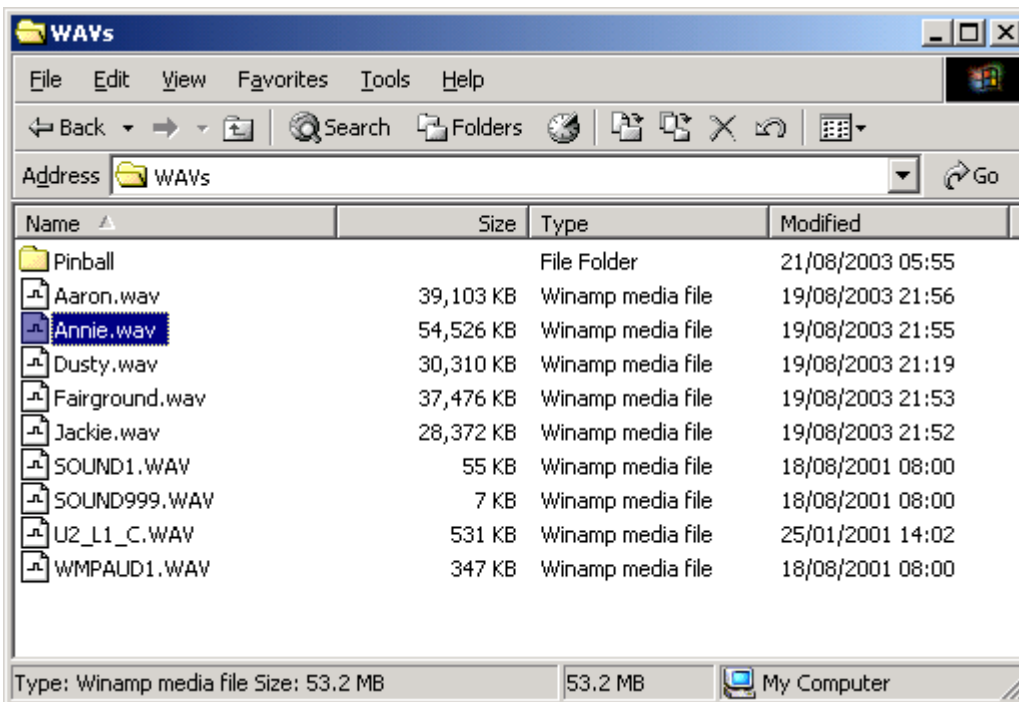

From this selected file/s can be dragged from the Explorer window onto the SpotOn button/s, again multiple selections will load into consecutive buttons overwriting any previously loaded tracks.

As an alternative to selecting the Browse option, single or multiple files can be drag and dropped from any Windows Explorer window that may be open.

[Getting Started 3](#)

## Getting Started 3

Once a button has been loaded the button right-click menu will contain many more options.

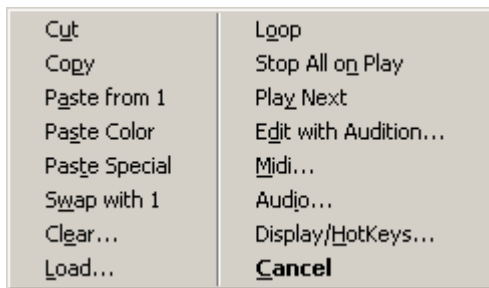

The items in the left hand column deal with the button as a whole, the items on the right cover the parameters of the track loaded into the button.

The **Cut**-to clipboard, **Copy**-to clipboard and **Paste**-from clipboard options allow tracks to be moved between buttons, Paste Colour will take the colour of the "Copied" button and paste it to a destination button enabling say, a set of buttons with similar sounds to have the same colour. **Paste Special** allows selected parameters to be copied to multiple buttons.

**Swap** will exchange the button that was "Copied" to the clipboard with the currently selected button.

**Clear** will remove all references to a track from a single button

**Load** displays file selection dialog for loading of a new track to this button.

Paste and Swap menus show the source button number that provided the data copied to the clipboard.

The first three items in the right hand column are options that can be checked or unchecked.

**Loop** when checked will cause the track play command to start playing the track in a continuous loop, the track will loop between In and Out points if they are present

**Stop All on Play** if this option is checked, when the track begins to play all other tracks being played will fade out using their individual fade times, this is indicated by a small solid square halfway up the right hand edge of the button.

Alternatively tracks can be set to stop immediately without fades by muting the audio on this button (see [Audio Setup](#)), in this case the solid square box icon is replaced by a square outline

A further option is to stop all tracks on the current page only, here the button icon appears as a solid or outline diamond., this is enabled via the [Midi selection](#) see later

**Play Next** checking this option will cause the track contained in the next numbered button to play when this track reaches the end, this is indicated by a small right facing arrow halfway up the right hand edge of the button. If the next numbered button is unassigned then no other track will be played

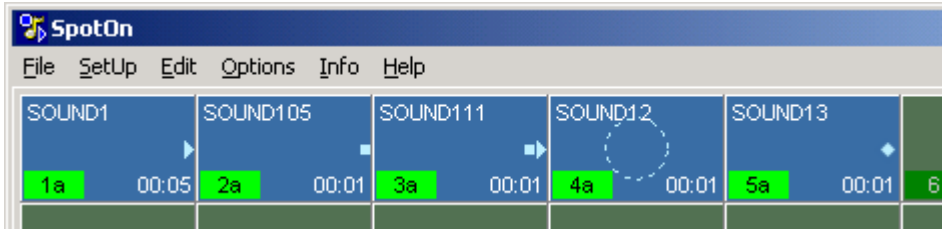

When the track on button 1 reaches the end or the start of its fade out, Button 2 will begin to play

When button 2 plays any other tracks that may be playing will be stopped using their fade out times

When button 3 is played it will also stop any other tracks that are currently playing and will then play button 4 when the track on button 3 reaches the start of the fade out.

Button 4 is set to loop continuously

Button 5 will stop all tracks on current page

**Edit** *EditorName* opens up the user defined WAV file editor, this editor is selected via [SetUp|Editor](#) menu. If an editor is assigned the name of the editor will be shown in the menu.

**Midi** see [Midi Assignment](#)

**Audio** see [Audio Setup](#)

**Display** see [Display Options](#)

[Getting Started 4](#)

## Getting Started 4

The Status bar at the bottom of the main window shows hints and the state of several options.



Working from the left:-

### **Data Rate**

176 KB/s

The current data rate of the audio streams being read from disk in bytes/second, note SpotOn has a predefined limit of 20MBytes/sec at which point the status text will change to yellow text on red background. Once the limit has been exceeded no more tracks can be started until the data rate falls below the limit.

176 KB/s

As a guide, a CD quality track has a data rate of 176kBytes/sec so the 20MBytes/sec limit should be more than adequate being equivalent to over 100 tracks.

176 KB/s

When SpotOn is set to work with multi-channel audio tracks, that is where the number of channels contained in a track is more than two, this status panel has a default green background. The multi-channel mode is enabled using [command line switches](#).

If the [Play Stack](#) is currently playing out a track then a new status bar panel will appear immediately to the right of the data rate panel, this Play stack panel will flash Yellow/Red, left-clicking on the panel will open up the Play Stack window.

Play Stack

Play Stack

Pyw Mode

SpotOn can playout buttons on a Preview output without affecting the main outputs, the Preview output is assigned with [Global|Preview Output Assignment](#).

00:00:10m

If Midi timecode is detected and Midi In is enabled then the timecode value will be shown with the addition of an 'm' suffix.

08:39:32x

Similarly if [SMPTE timecode](#) is being used then it will be displayed but with the addition of an 'x' suffix indicating external timecode.

08:39:32i

If the timecode is being derived from a button track then the suffix will be 'i' (internal)

10:00:01x

If [Timecode Chase](#) mode is active then the timecode value will be shown in magenta text

## Hints

55.8 MB o/p A3, Fade Out, Log Fade, Play Next

Hint for the button under the mouse pointer, detailing file size, allocated output and any other modifiers. In this example 'A3' shows the allocated output port is A and suffix 3 indicates that it was the third button to be allocated to port A - this becomes important when utilizing sound card hardware mixers to produce smooth fades.

This panel will have a yellow background when [Prep mode](#) is active.

SpotOn running in Preparation Mode

## Midi In

Midi In Off

The brown background to the text indicates no Midi In devices have been assigned, see menu [SetUp|Midi Devices](#) and would normally mean no Midi input triggers can be accepted. However, if [Midi Loopback](#) is enabled (see below) then clicking this panel will enable/disable the Midi In functions without the need for any real Midi devices, (used when the Midi out messages are internally looped back to the Midi In port).

midi in on  
midi in off

If Midi loopback is on then the Midi Out panel text will be in lowercase

Midi In Off

A Midi In device has been assigned but Midi In messages are not enabled clicking this panel will disable/enable Midi In.

Midi In On

A Midi In device has been assigned and Midi In messages are enabled, clicking this panel will disable/enable Midi In.

Midi In On

If multiple buttons are assigned the same Midi In note and are to be played out in overlapped mode the text will be underlined as will the Midi In note descriptions displayed on the buttons (see [SetUp|Midi Devices](#) for further details).

*Midi In On*

If the option to use [Midi In over UDP](#) is enabled then the text will be in italics

Midi In On

Midi In On

The panel text will flash red when incoming Midi In message is detected.

## **Midi Out**

Midi Out Off

A Midi Out device has not been assigned, see menu [SetUp|MidiDevices](#)

midi out off

A Midi Out device has not been assigned, but Midi loopback is selected

Midi Out Off

A Midi Out device has been assigned but Midi Out messages are not enabled, clicking this panel will disable/enable Midi Out.

Midi Out On

A Midi Out device has been assigned and Midi Out messages are enabled, clicking this panel will disable/enable Midi Out.

Midi Out On

The panel text will flash red when Midi Out message is sent.

midi out on

A Midi Out device has not been assigned, but Midi loopback is selected and is enabled

Midi Out On

Midi Out over network is enabled when text is underlined, example shows Midi over Network enabled but no real Midi device selected

Midi Out On

When [Network Master](#) enabled the text is shown in blue, example shows Network master enabled with a Midi device selected and Network Midi Master active

## **GPI In**

GPI In Off

A GPI In device has not been assigned, see menu [SetUp|GPI Triggers](#)

GPI In Off

A GPI In device has been assigned but GPI In events are not enabled

GPI In On

A GPI In device is assigned and GPI In events are enabled, clicking this panel will disable/enable GPI In

GPI In On

The panel text will flash red when a GPI In event is detected.

## **PBus**

When PBus control is enabled the text in the GPI In panel is shown underlined

**GPI In On** A GPI In device has not been assigned and PBus Control is enabled

**GPI In On** The panel text will flash cyan when a PBus trigger event is detected.

**GPI In On** GPI In device has been assigned and PBus Control is enabled

Shift right-clicking on the GPI In panel will toggle the PBus control enabled/disabled

## **Links**

**Links Off** Groups and Master/Slave links are disabled

**Links On** Groups and Master/Slave links are enabled, clicking this panel will disable/enable button linking

## **HotKeys**

**HotKeys Off** HotKeys are disabled

**HotKeys On** HotKeys are enabled, clicking this panel will disable/enable HotKeys, if [Overlapped](#) mode is selected and there are duplicate

**HotKeys On** Hotkeys assigned the text will be underlined

## **Play Mode**

**Play/Menu**

Mouse button functions are - Left Button alternatively plays and stops track, Right button brings up menu

**Play/Stop**

Mouse button functions are - Left Button plays and right button stops track, shift+right button brings up menu

Mouse mode can be changed by left clicking on the panel or via menu [Options|Mouse Functions](#)

When using a touchscreen to control SpotOn sometimes it may be necessary to debounce the "presses" (left-clicks) made by the user so that the track is not restarted unintentionally. Under the

[options menu](#) the debounce time can be set and when in use it is indicated by the lower right status panel text being shown in white on blue as below.

Play/Stop

The five button attributes MidiIn, MidiOut, GPIs, Links and Hotkeys above can be displayed as highlighted button numbers by right clicking the appropriate status bar panel.

The panel will change colour to orange and the numbers on the buttons that have those attributes are also set to orange, the remaining button numbers are set to dark grey

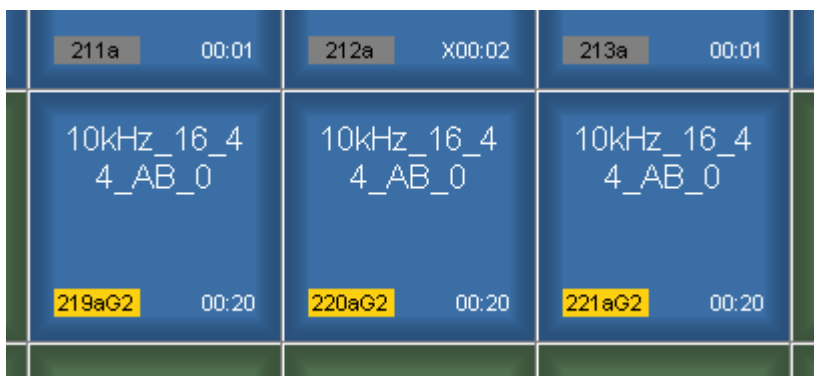

Similarly the output assignments can be shown on screen by right-clicking the mouse mode panel on the right hand side of the status bar. This will offer a popup menu listing all the available audio outputs, selecting one of them will highlight the buttons on the screen as described above.

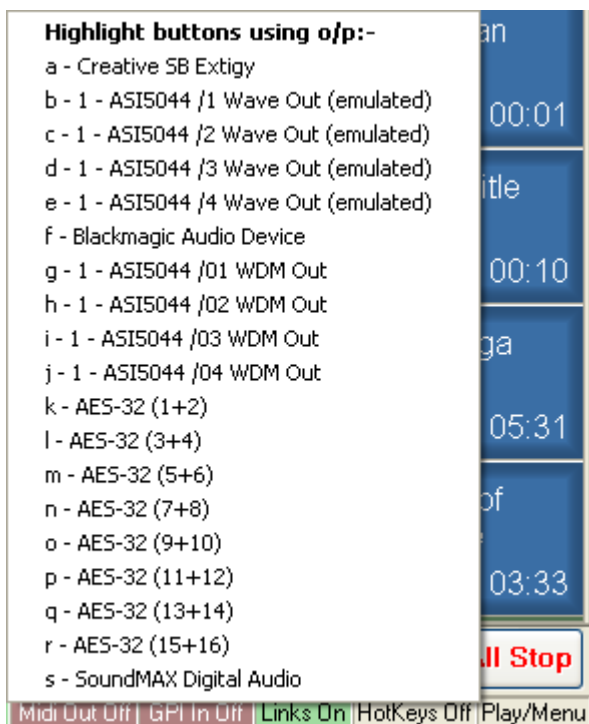

The button highlight can be used to show buttons with a specific sample rate, this mode is selected by shift right-clicking the mouse mode panel.

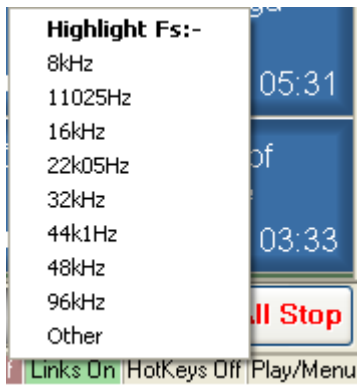

The button highlight can be used to show buttons with a specific number of channels, this mode is selected by control right-clicking the mouse mode.

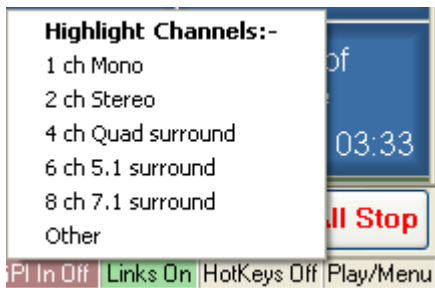

Finally the button highlight can be used to show buttons with a specific bit depth, this mode is selected by shift+control right-clicking the mouse mode.

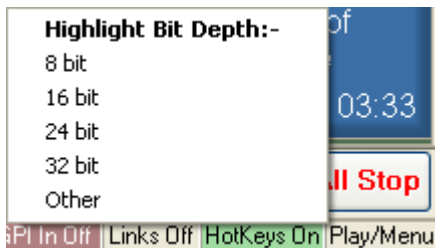

In all the highlighting modes the action will automatically cancel after 5 seconds or can be cancelled manually by right-clicking the panel a second time.

Example of a typical screen layout

The screenshot displays the SpotOn software interface, which is used for managing broadcast schedules. The main area is a grid of colored boxes, each representing a program segment. Each segment contains a label, a unique ID (e.g., 76a), and a duration (e.g., 00:37). The segments are arranged in a 5x5 grid. Below the grid is a control bar with buttons numbered 1 through 8, and an 'All Stop' button. At the bottom of the window, there is a status bar showing system information like '0 Bytes/s' and '1.93 MB o/p A, Fade Out, Linear Fade'. The Windows taskbar is visible at the very bottom, showing the 'start' button, system tray icons, and the time '12:09'.

Segment ID	Label	Duration
76a	Opening Sting	00:37
77a	Headlines	00:45
78a	Opener Stab	00:06
79a	RoundUp V1	00:44
80a	RoundUp V2	00:07
81a	Headline VO Chris	00:06
82a	Headline VO Martin	00:06
83a	Headline VO Katie	00:06
84a	Countdown	00:07
85a	Countdown V2	00:07
86a	15-AudioTrack 15	00:11
87a	15-AudioTrack 15	00:11
88a	Track 22	00:06
89a	Track 23	00:06
90a	01-AudioTrack 01	00:37
91a	ITV Bed 40s	00:41
92a	Short Break	00:06
93a	Short Break	00:06
94		00:00
95a	06-AudioTrack 06	01:23
96a	02-AudioTrack 02	00:45
97a	ReCap	01:23
98a	ReCap Close	00:18
99a	Close 43s V1	00:44
100a	Close 43s V2	00:44

# Main Menu

 SpotOn

[File](#) [SetUp](#) [Display](#) [Edit](#) [Search](#) [Global](#) [Options](#) [Info](#) [Help](#)

[File](#)

[SetUp](#)

[Display](#)

[Edit](#)

[Search](#)

[Global](#)

[Options](#)

[Info](#)

[Engineering](#)

[Admin](#)

[Help](#)

# File Menu

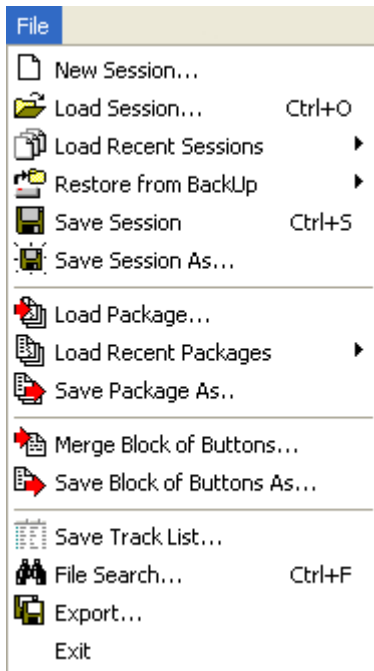

## [New Session](#)

Clear all pages to start a new session

## [Load Session](#)

Load data file containing complete setup information

Load Recent Sessions

Displays a list of recently accessed Sessions

## [Restore from BackUp](#)

Restore session from timed backup file

Save Session

Save data to last loaded/saved disc file

## [Save Session As](#)

Save data to a specific file

## [Load Package](#)

Load file containing setup information and audio files

Load Recent Packages

Displays a list of recently accessed Packages

## [Save Package As](#)

Save file containing setup information and audio files

## [Merge Block of Buttons](#)

Load block of consecutive buttons

## [Save Block of Buttons](#)

Save a block of consecutive buttons

## [Save Track List](#)

Save track data in a spreadsheet compatible format

## [File Search](#)

Opens an external file search utility

## [Export](#)

Export copies of tracks to single folder

## [Exit](#)

Close down SpotOn and save debug status files

## New Session

In addition to clearing all the buttons this option will load the file ~newsession.dta if it is present in the Application Data folder, this file can be saved just as any other session file so allowing loading of a customised new session.

Application Data folder = ..\Documents and Settings\All Users\Application Data\Serialtech\SpotOn\

## Load Session

Load a new session into SpotOn see [Load Session](#) page for an explanation

## Save Session As

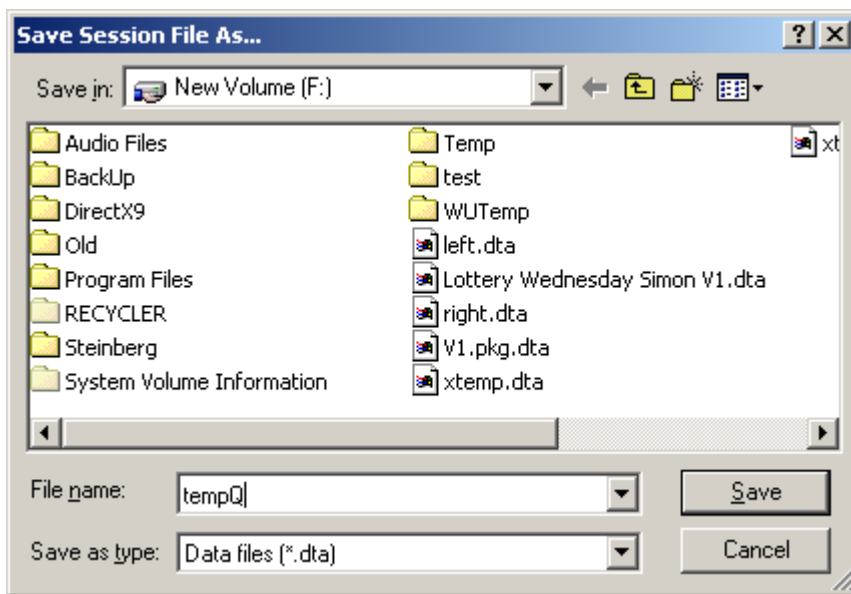

This saves the current session to disc, for SpotOn to locate the files the extension must be '.dta' this is added automatically. In the example above the file would be saved as 'tempQ.dta'.

If an invalid file extension is entered as part of the filename then it will be rejected.

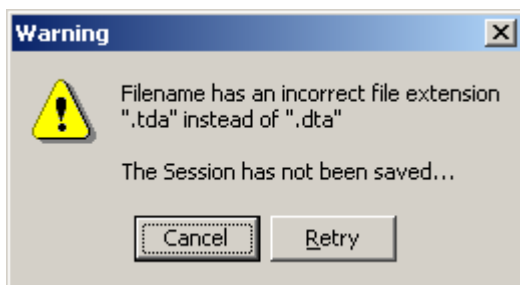

## Restore from BackUp

To restore a session from the automatic backup files, select a file based on the time and date that is most likely to contain the data required

11:27 today	16:54 yesterday
11:03 today	18:23 Sun 11 Apr
11:00 today	14:39 Sun 11 Apr
18:00 yesterday	14:34 Sun 11 Apr
17:20 yesterday	14:29 Sun 11 Apr
17:09 yesterday	14:24 Sun 11 Apr
17:04 yesterday	14:19 Sun 11 Apr
16:59 yesterday	14:14 Sun 11 Apr

## Load Package

A Package file (\*.pkg) can be loaded to recreate a complete setup including replacing the audio WAV files, as this may take up a large amount of disc space the location of the extracted audio files can be changed during loading from the default of SpotOn\Package Media\ to a more appropriate location, the default location is set via [Admin|File Folders](#)

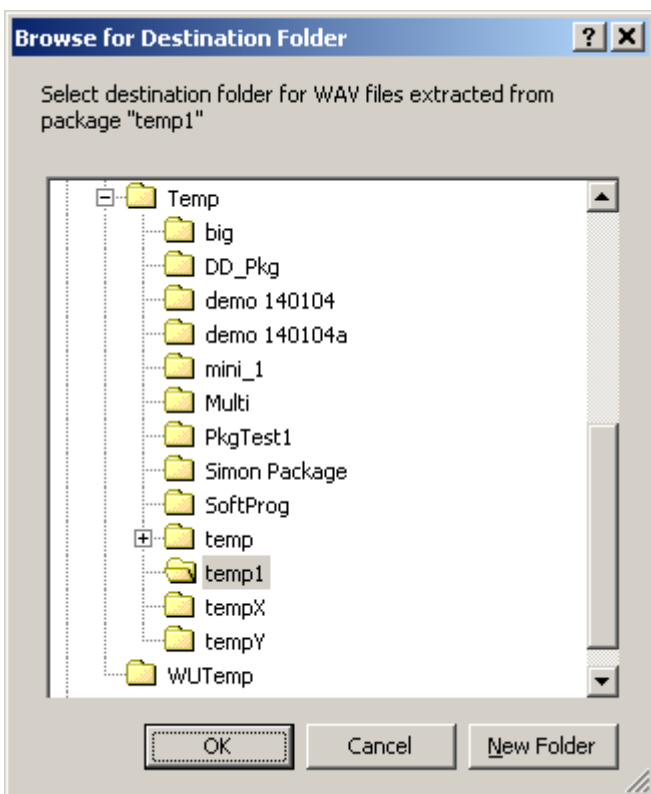

If SpotOn detects that the package being loaded was built with a version of the program that is more recent than the current version, then the warning dialog box below will appear.

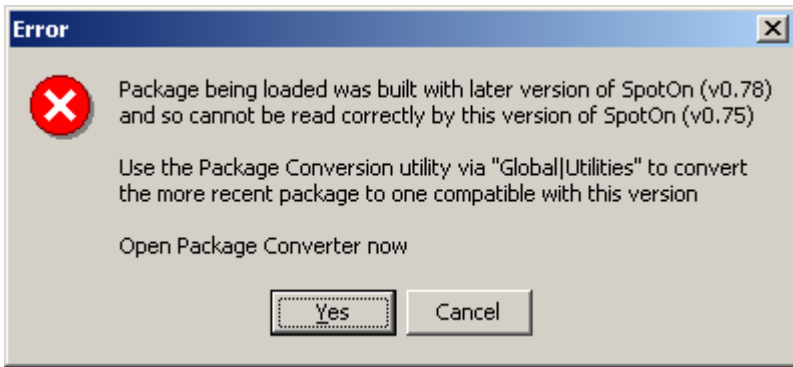

Clicking Yes will open the [Package Converter](#) utility, the Package Converter utility used must be the latest version and that can be found on the Serialtech web site - [PackageConvert.zip](#).

If the loaded package file contains less than the maximum number of buttons (<320) - a Mini package - then the option will be offered to merge the buttons into a specific place within the existing buttons.

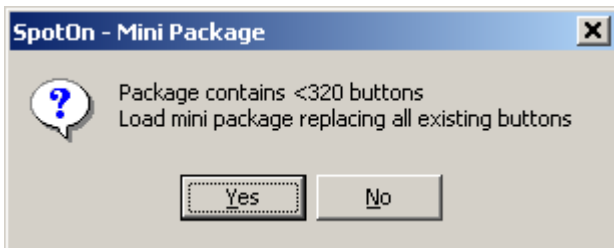

If Yes is selected all buttons in SpotOn will be cleared and then loaded from the Mini package starting at button 1.

If No is selected a further option is offered defining where the mini package will be merged into the existing set of buttons

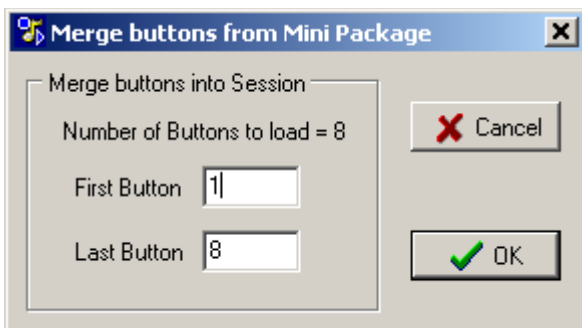
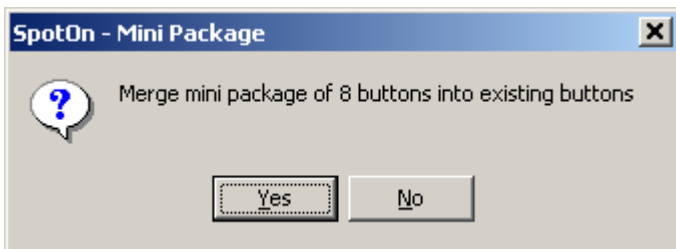

Default positioning starting at button 1, can be changed as below to start on any button.

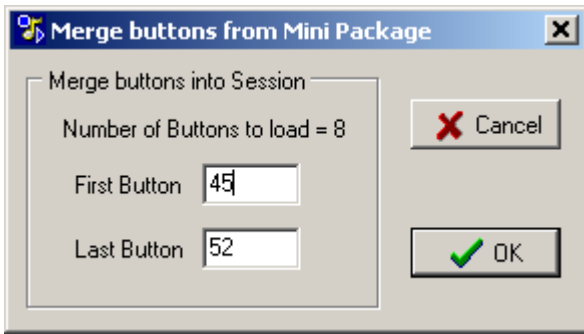

Depending on the length of the original filenames and the length of the name of the new folder, it is possible that the length of the overall path name may exceed the limit set by Windows. If this is the case then the filenames will be truncated but remain unique.

## Save Package As

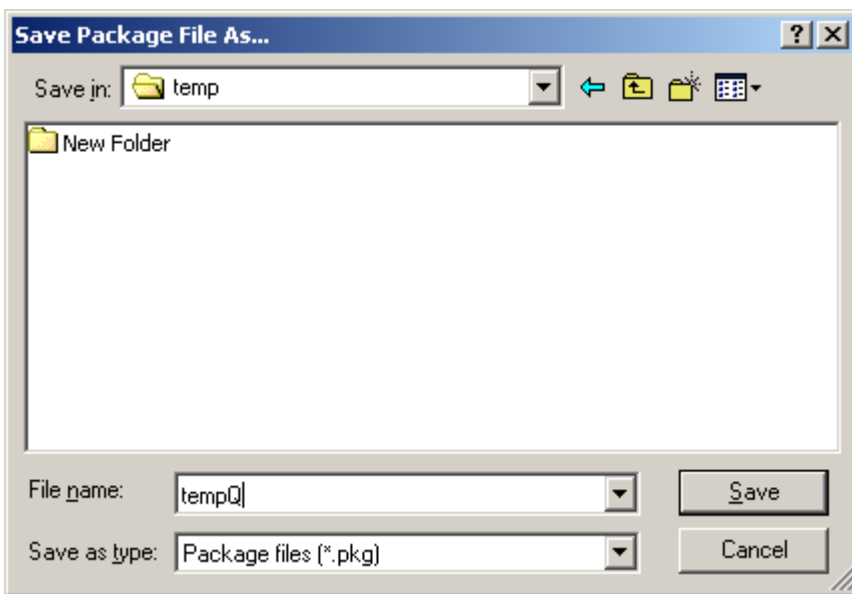

This option will save all the individual button settings along with the audio WAV files, consequently the resulting package file (\*.pkg) can be very large, with CD quality audio the file will take up approximately 10MB for each minute of audio saved.

This package file can then be reloaded into the same computer or another computer running SpotOn to recreate the original setup.

There is a utility program provided with SpotOn called [UnPackageWAVs](#) that can extract the audio WAV files from the package file, this may be useful when working offline without access to SpotOn to review the audio material. The utility can also export audio tracks with the trim and gain settings applied by SpotOn.

A Package can contain any number of consecutive buttons between 1 and the maximum of 320

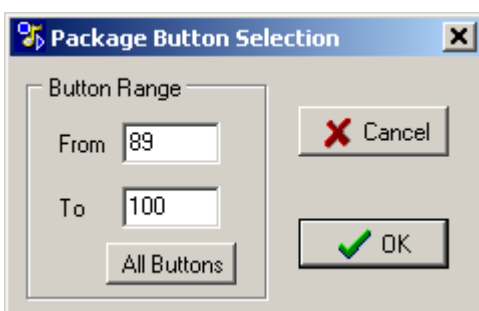

If the package does not contain all buttons then it is termed a Mini Package and can be merged into an existing set of buttons.

This saves the current package to disc, for SpotOn to locate the files the extension must be '.pkg' this is added automatically. In the example above the file would be saved as 'tempQ.pkg'.

If an invalid file extension is entered as part of the filename then it will be rejected.

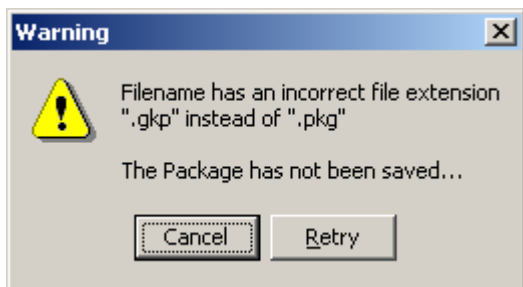

If a [CD/DVD burner utility](#) has been assigned then after the package has been saved there is then the option to burn it to CD or DVD.

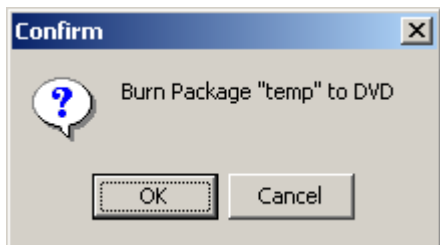

## Merge Block of Buttons

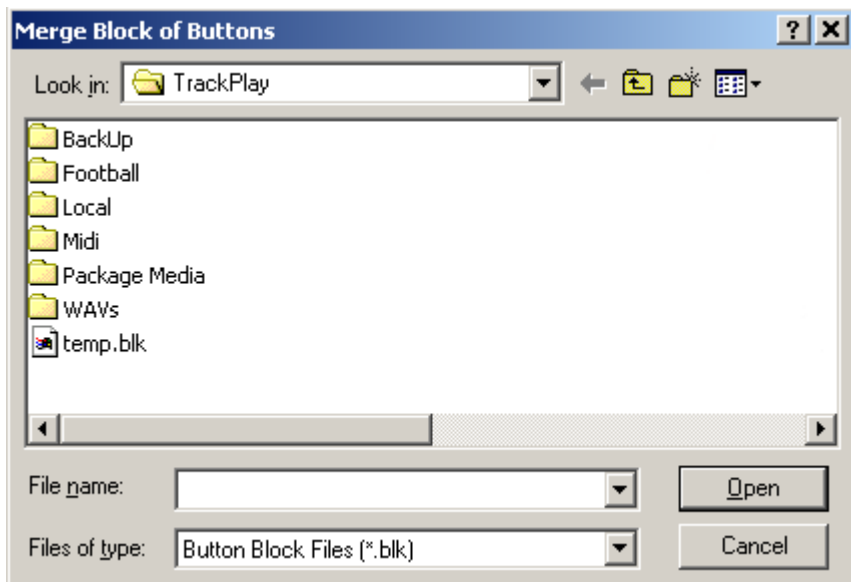

Having selected the file to retrieve the block of buttons, the first button of the sequence has to be defined, the number of buttons to be loaded is fixed in the file

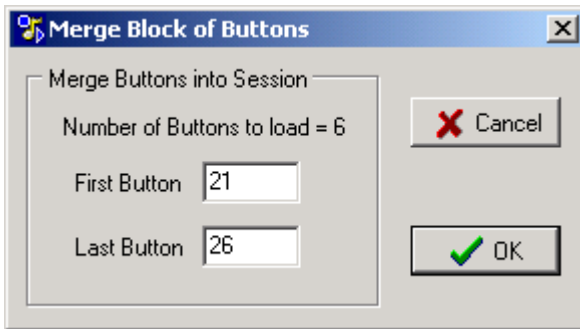

## Save Block of Buttons

A continuous numerical run of buttons can be saved to a file, this can be used for a set of tracks that are commonly used and can be imported into new setups

Select a file to store the block of buttons

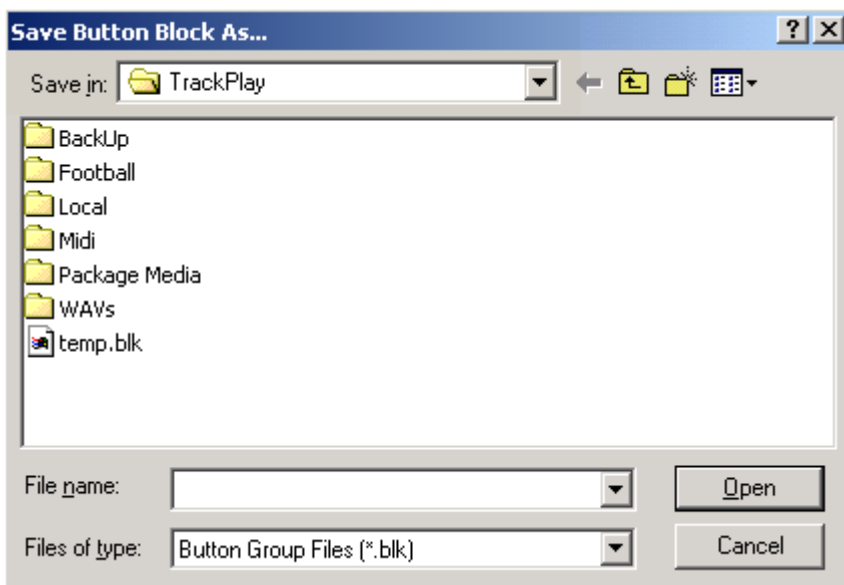

Then select the continuous range of buttons to save

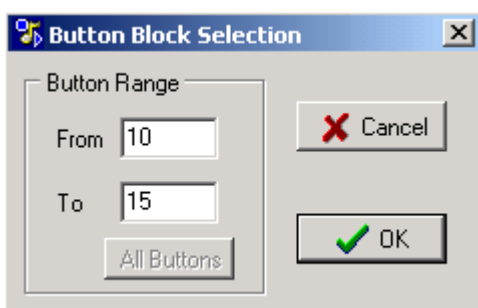

If an invalid file extension is entered as part of the filename then it will be rejected.

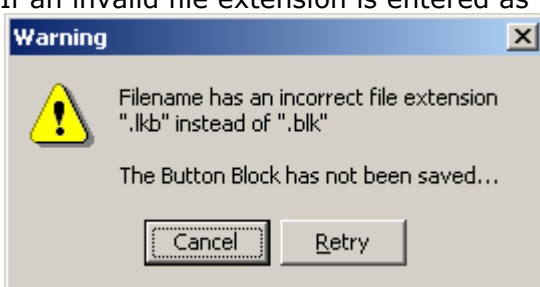

## Save Track List

A Track List contains the settings of the assigned buttons the data is saved as both a text file (\*.txt) and a comma separated variable (\*.csv) file

A typical section of a Track List file (\*.csv) imported into MS Excel

	A	B	C	D	E	F	G	H	I	J	K	L
1	#	TrackName	Length	Output	Gain	Left	Right	Speed	Trim In	In Point	Trim Out	Out Poi
2	2	SOUND1	00:00:05:02	a	0dB	0dB	0dB	0%	No	00:00:00:00	No	00:00:00
3	3	SOUND1	00:00:05:02	a	0dB	0dB	0dB	0%	No	00:00:00:00	No	00:00:00
4	4	SOUND1	00:00:05:02	a	0dB	0dB	0dB	0%	No	00:00:00:00	No	00:00:00
5	13	ding	00:00:00:69	e	0dB	0dB	0dB	0%	No	00:00:00:00	No	00:00:00
6	28	AudioTrack 09 (range)	00:00:08:01	e	0dB	0dB	0dB	0%	No	00:00:00:00	No	00:00:00
7	30	AudioTrack 14 (range)	00:00:11:51	e	0dB	0dB	0dB	0%	No	00:00:00:00	No	00:00:10
8	38	AudioTrack 14 (range)	00:00:11:51	e	0dB	0dB	0dB	0%	No	00:00:00:00	No	00:00:10
9	66	SOUND1	00:00:05:02	a	0dB	0dB	0dB	0%	No	00:00:00:00	No	00:00:00
10	67	SOUND1	00:00:05:02	a	0dB	0dB	0dB	0%	No	00:00:00:00	No	00:00:00
11	69	SOUND1	00:00:05:02	a	0dB	0dB	0dB	0%	No	00:00:00:00	No	00:00:00
12	70	SOUND1	00:00:05:02	a	0dB	0dB	0dB	0%	No	00:00:00:00	No	00:00:00
13	77	ding	00:00:00:69	a	0dB	0dB	0dB	0%	No	00:00:00:00	No	00:00:00
14	92	AudioTrack 09 (range)	00:00:08:01	e	0dB	0dB	0dB	0%	No	00:00:00:00	No	00:00:00
15	94	AudioTrack 14 (range)	00:00:11:51	e	0dB	0dB	0dB	0%	No	00:00:00:00	No	00:00:10
16	102	AudioTrack 14 (range)	00:00:11:51	e	0dB	0dB	0dB	0%	No	00:00:00:00	No	00:00:10

## File Search

The menu item will run an external file search utility this utility may be customised to the type of files required, the utility is selected via [SetUp|Search](#) and the default program is [SpotOnSearch](#)

## Export

For convenience SpotOn provides an export facility to copy all the currently used audio files to a single folder, this does not change the files or locations used by the application.

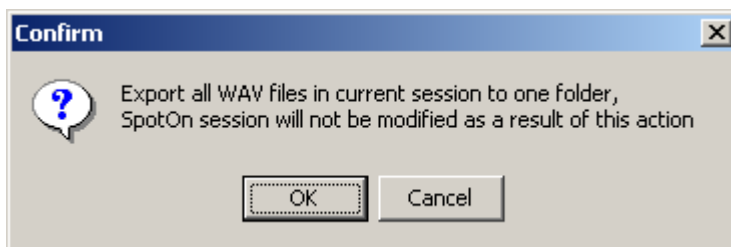

The destination folder is then selected

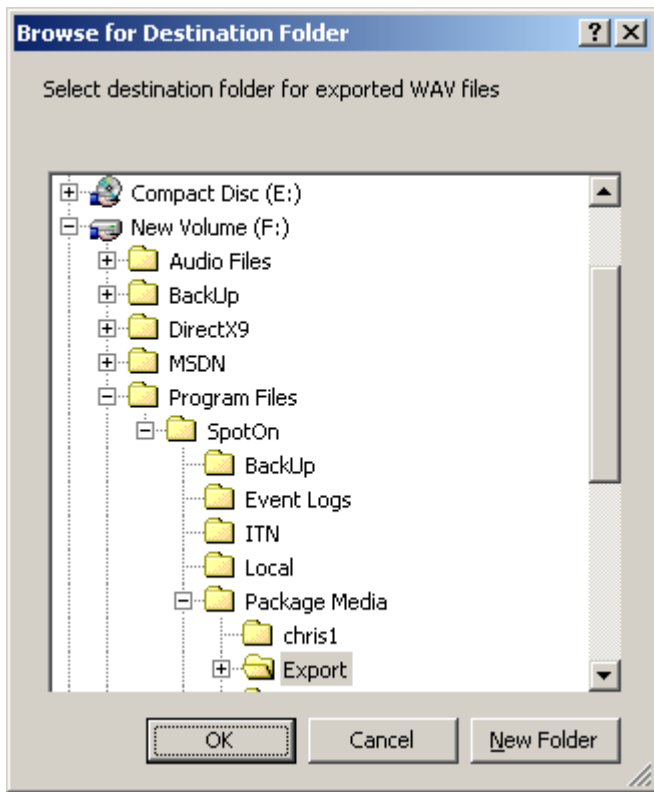

Next an option to export the files only from the buttons on the current page or from buttons on all pages is presented

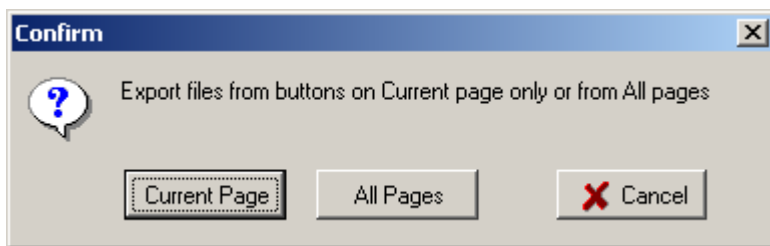

If a filename is found in the destination folder that is the same as any of the files being exported a warning dialog will be shown

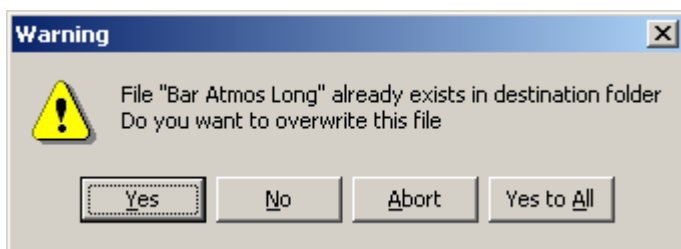

## Exit

This option will close down SpotOn and save a debug status file ~StatusLog.txt to the application data folder, found at:-

Windows 7 - C:\Program Data\Serialtech\SpotOn

Windows XP - C:\Documents and Settings\All Users\Application Data\Serialtech\SpotOn

Windows 2K - C:\Documents and Settings\All Users.WINNT\Application Data\Serialtech\SpotOn

This file is only overwritten when SpotOn is closed via the File|Exit route, exiting the program with the more usual Windows close button leaves the file intact.

This mode will be useful in debugging problems, if a problem should occur close down SpotOn and then save the ~StatusLog.txt file to another folder, the zip the file and EMail it to your supplier along with a detailed description of what problems occurred.

More comprehensive debug logs can be saved via the [Global|Utilities menu](#)

# Load Session

## Load Session

This option will load the selected session file which will contain the button assignments and any parameters that have been set such as Master/Slave links, Hotkeys etc., to achieve this the audio tracks are assumed to be in the same location (disk drive/folder) as they were when the session was saved.

However it is possible that the audio tracks have been moved or possibly deleted, in this case SpotOn will report any missing files as shown below along with their last known location.

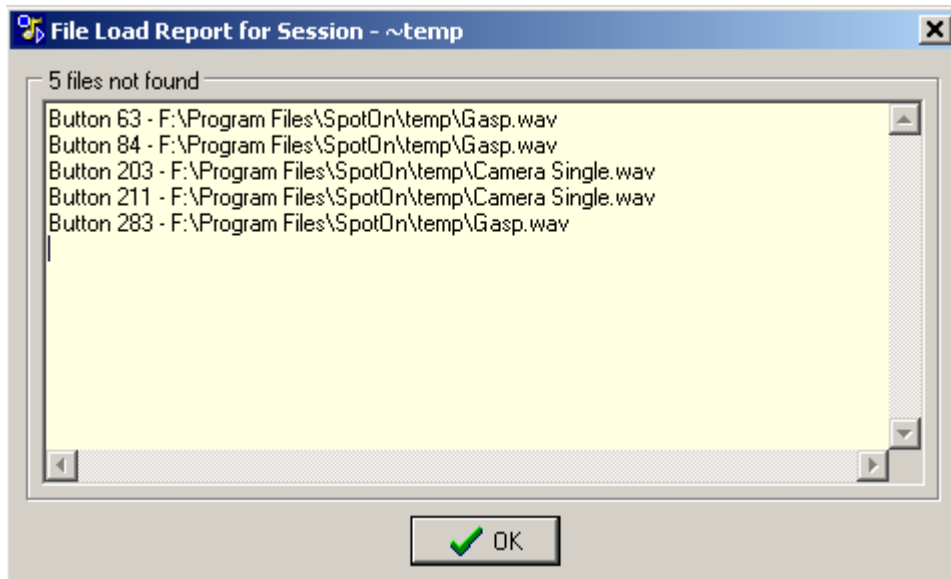

If the [Try Remote Files](#) option is checked, then the program will also attempt to search for the missing files in the location from which they were originally loaded eg CD or remote disk drive and then report as below.

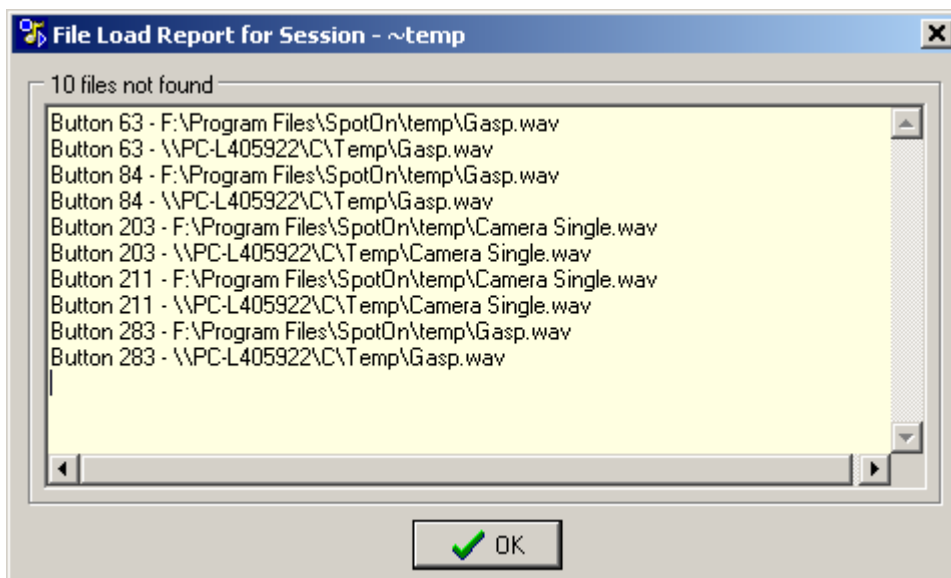

Here there are two entries for each button, the first for the local copy of the file and the second for its original location, these reports are saved to the log file which can be viewed via [Info|Logs](#)

SpotOn will also detect audio files with a timestamp that is not the same as that when the session file was saved, usually indicating the file has been recently edited.

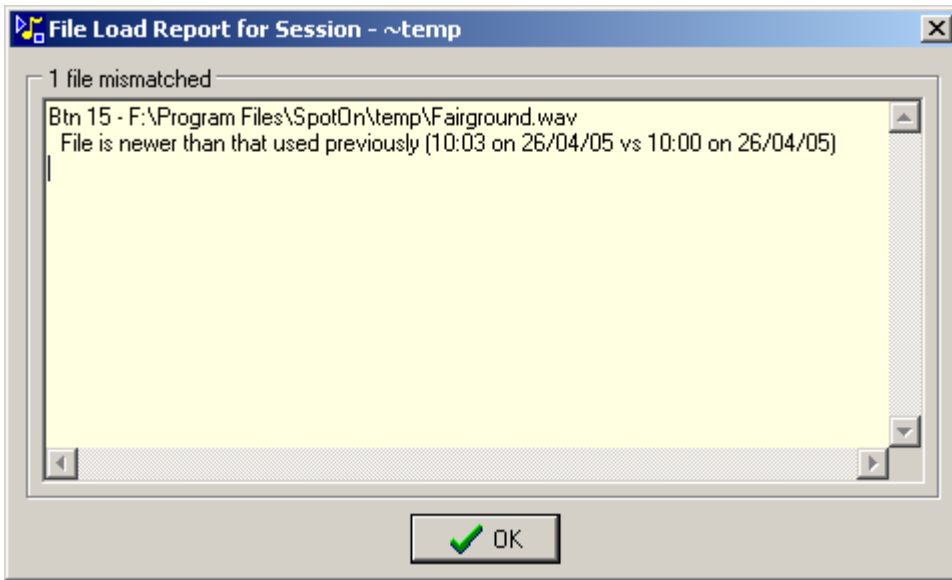

In this case if the playlist information has changed and it is possible the new playlist entries will be merged with the originals, also any fade out points that are now beyond the end of the file will be reset to default values.

This loading report is copied to the Event logs found under [Info|Logs|Events](#) so that any parameters changed can be reentered.

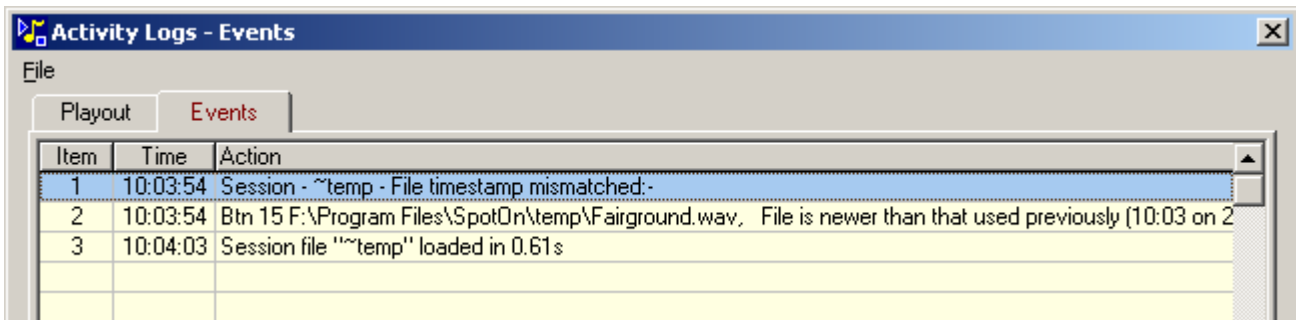

As a result of the possibility that some audio tracks may not be found or timestamps have been changed unintentionally by copying files, it is recommended that the session and audio data are saved together in a [Package](#).

### File Not Found

If files cannot be found, the buttons concerned are shown with the text 'File not found' instead of the Trackname



**Note:** It is important that a copy of the original session file is made using Windows Explorer before any attempts are made to recover missing files, this is to ensure the original session data is not inadvertently modified.

The right-click menu on this button contains an extra entry 'Locate File'

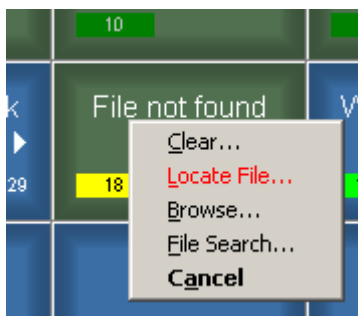

Choose Locate File to find the missing file and copy it to the original location where SpotOn was expecting to find the file or to copy it to a new location and modify the session file accordingly.

The Locate File dialog is shown below, on the left hand side is the procedure for locating/copying the file and on the right hand side the file locations.

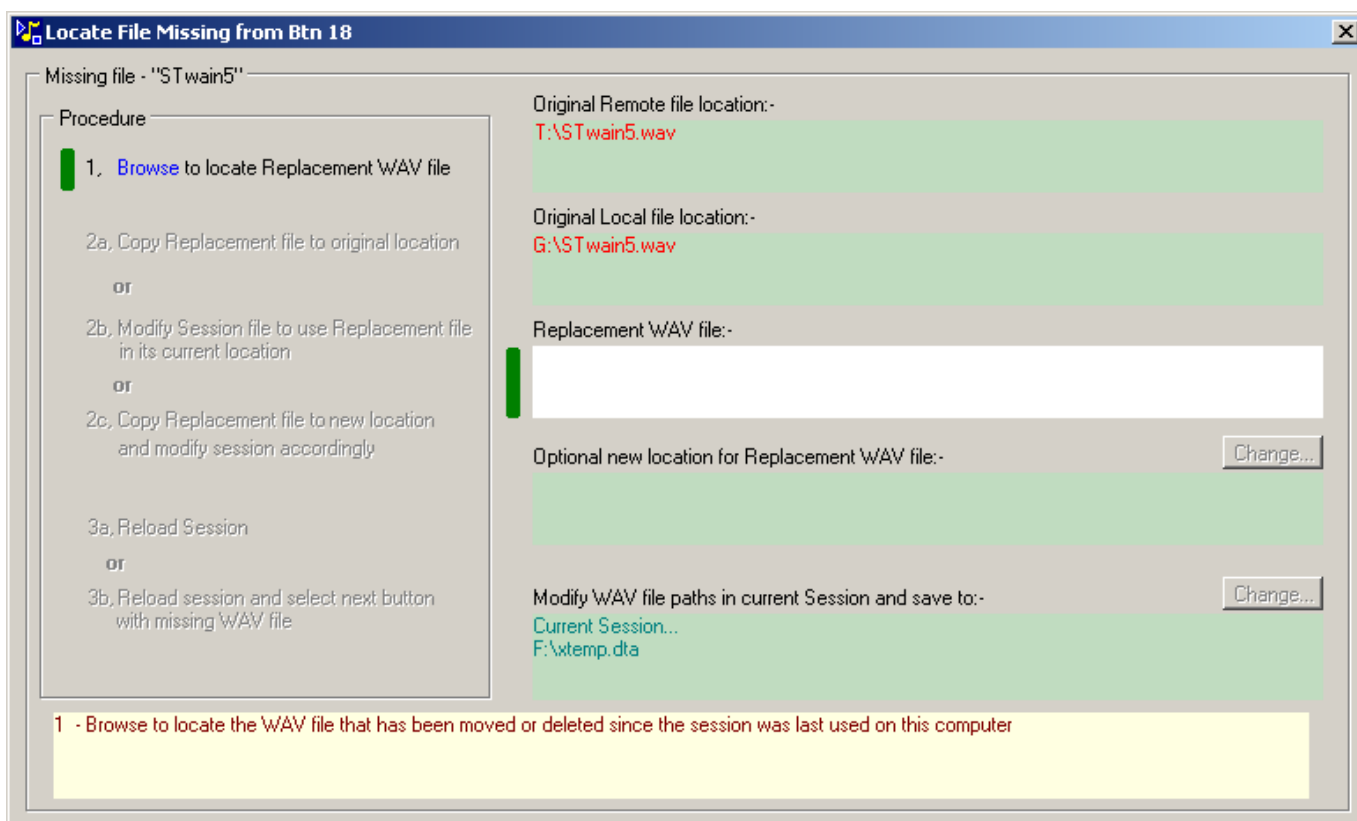

### Folder locations:-

Working down from the top right - the Original Remote File location points to the original source of the track, this could be a CD or server which maybe no longer accessible, in which case it will be shown in red text.



The Original File location is where SpotOn expected to find the file, again this will be shown in red text if the location cannot be accessed

Original Local file location:-  
G:\STwain5.wav

The Replacement WAV location is where SpotOn will now look for the audio file

Replacement WAV file:-

Once a replacement file has been located it can be copied to a new location, SpotOn will change the references to the audio file to point to the new location, the 'Change' button opens a folder selection dialog allowing the new location to be specified.

Optional new location for Replacement WAV file:-

Lastly the session file that contains the changed filenames can be either the default current session or another new session file, the 'Change' button allows a new session file name to be entered

Modify WAV file paths in current Session and save to:-   
[Current Session...](#)  
G:\xtemp.dta

Modify WAV file paths in current Session and save to:-   
[Alternate Session...](#)  
G:\xtemp2.dta

### Procedure:-

On the left of the dialog are listed the three steps to find the missing file, the steps are selected via hyperlinks indicated by blue text which is underlined when active, the vertical green bar shows the current step in the procedure.

Procedure  
1. [Browse](#) to locate Replacement WAV file

The first step is to locate the missing file, clicking on Browse will display a file dialog window

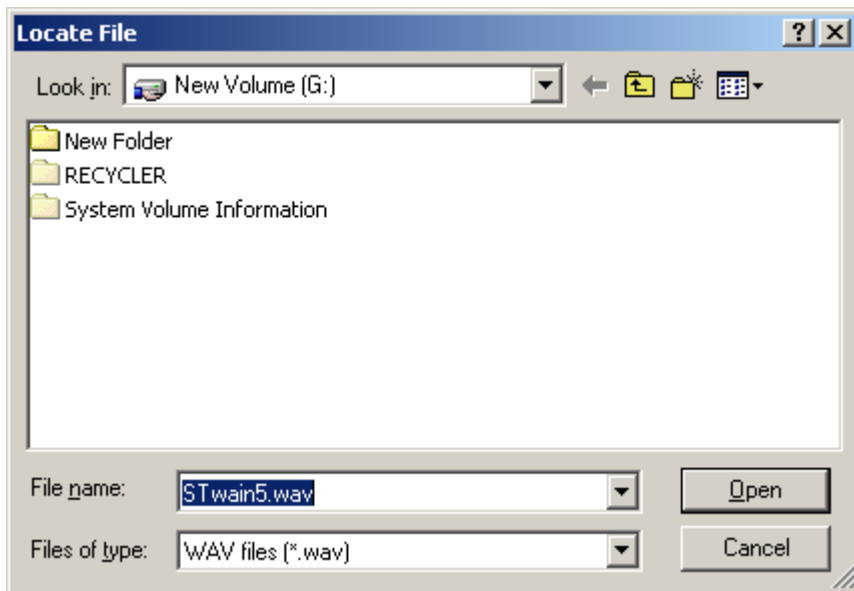

Here the file named 'STwain5.wav' no longer exists but in this case it is know to have been moved into the New Folder.

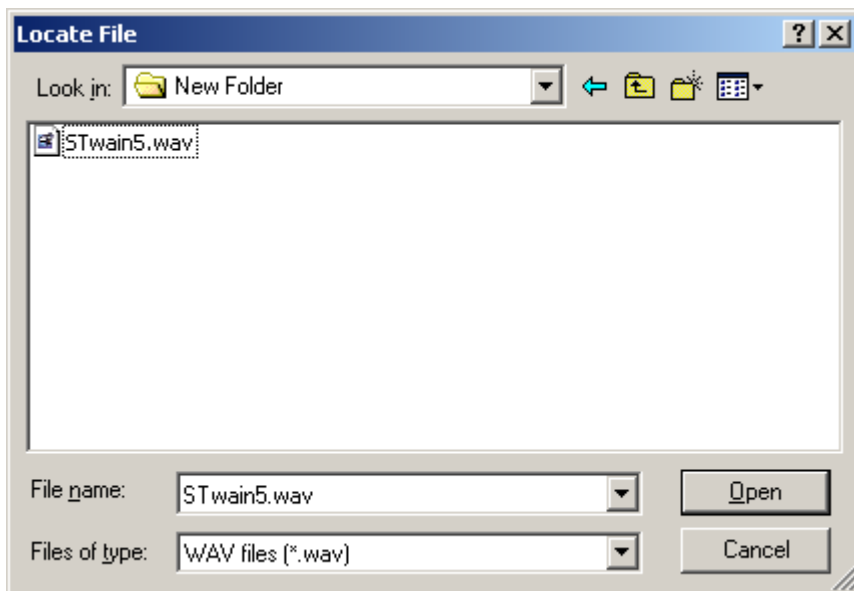

Once a replacement file has been assigned it is shown on the right of the dialog as a Replacement WAV file and the bar highlight on the far left moves to step 2

The hint panel at the bottom of the window give brief notes on the options available

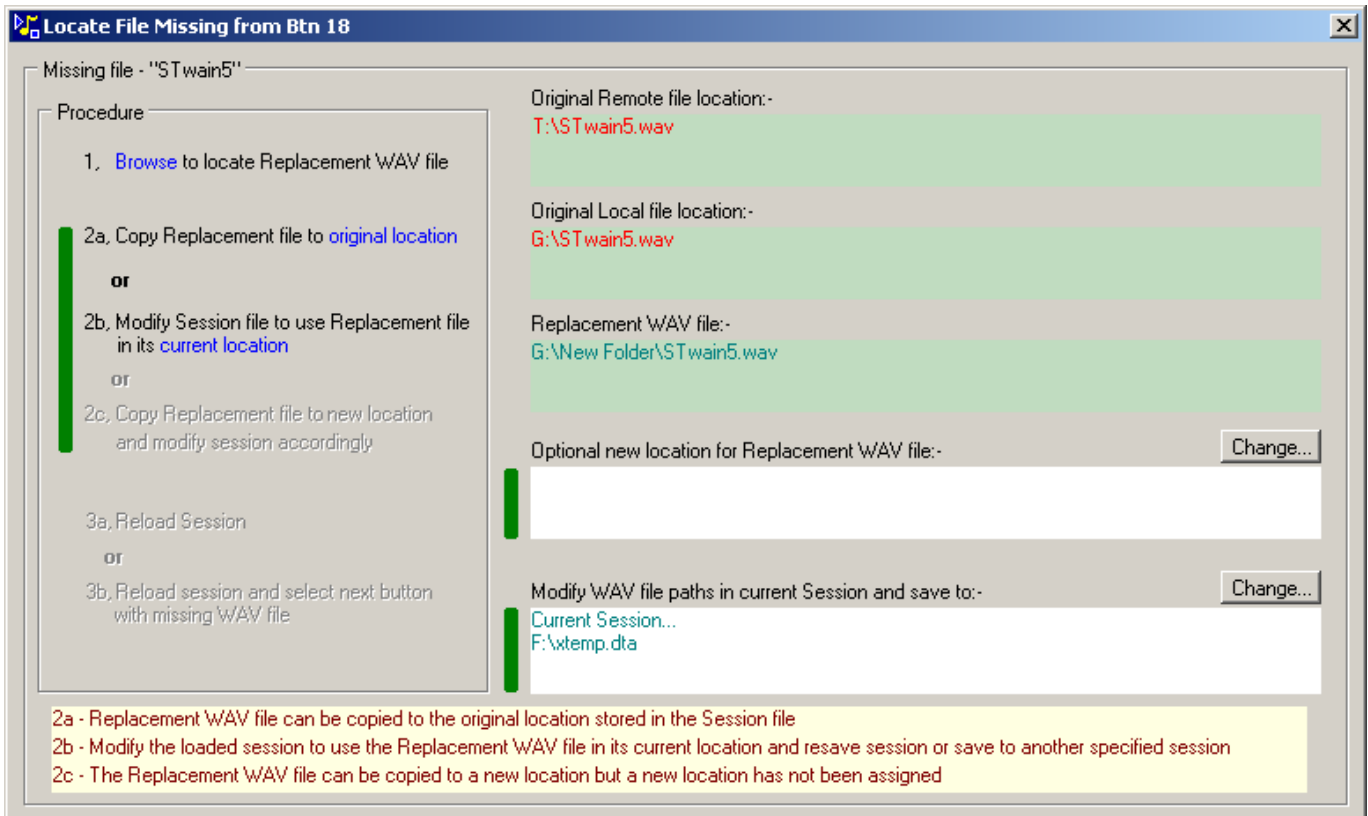

Some of the three options in step 2 may be disabled.

2a will be disabled if the original location does not exist on the computer, this may happen if a session has been copied from another computer or the computer disc drive configuration has been changed.

2b will always be enabled

2c is initially disabled until a new location is specified via the section below

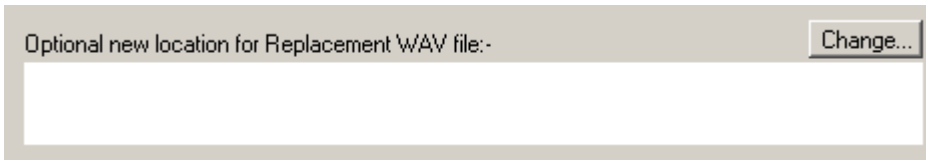

Click on the Change button to define a new location for the replacement WAV file

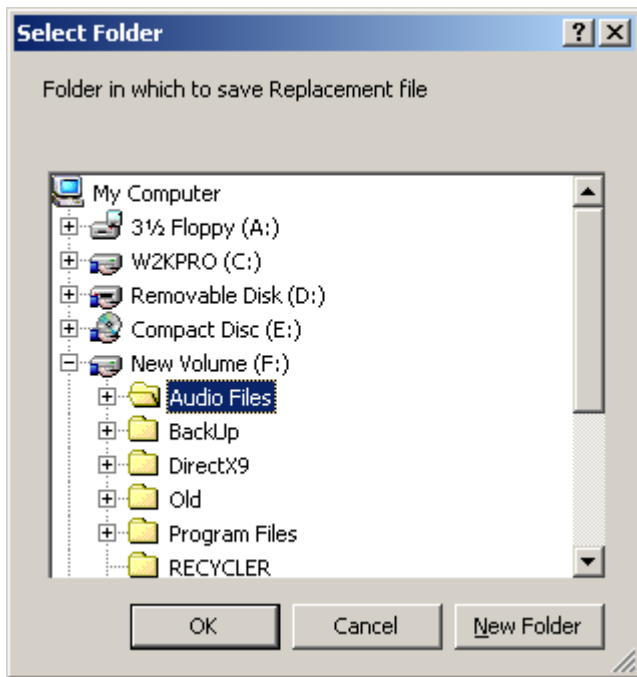

The alternative location is now specified and item 2c is enabled

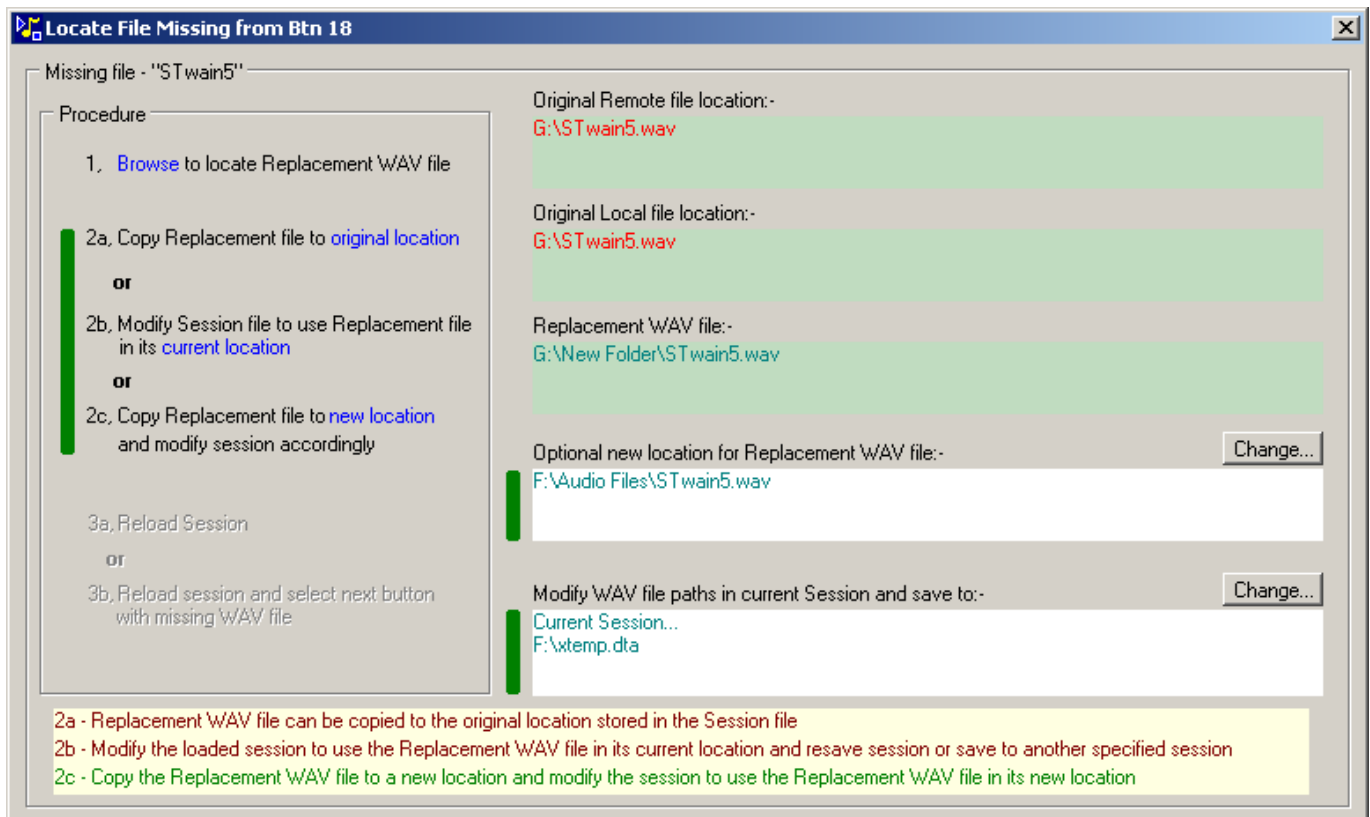

When the available options change the hint panel text is highlighted to indicate that it has been updated.

If the session data is to be modified the default is to modify the currently loaded session, alternatively another session name can be assigned by using the Change button

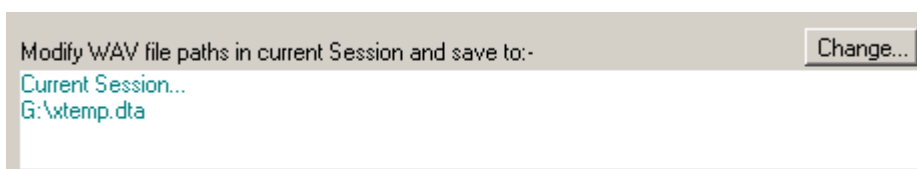

This displays a dialog box where the new session filename can be entered

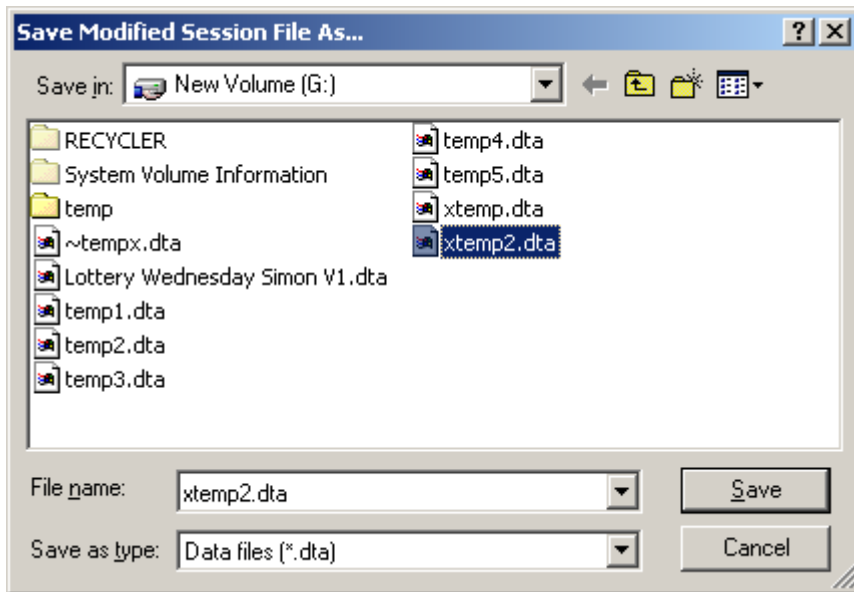

This is then reflected in the main dialog window

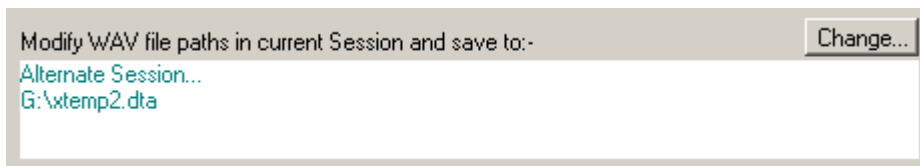

Clicking on any one of the options 2a, 2b or 2c will then move to step 3.

If when copying a file, a file of the same name is found in the destination folder a warning dialog will be shown

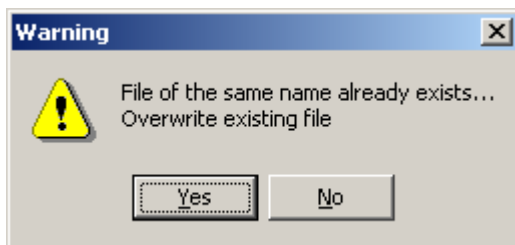

Finally on step 3 the two options are to reload the current session or to reload and select the next button with a missing WAV file.

Choosing 'select next button' will cause SpotOn to scan the remaining buttons for missing files and if the missing audio file is found in the same folder as the previous missing file then the session will be automatically modified with the new location.

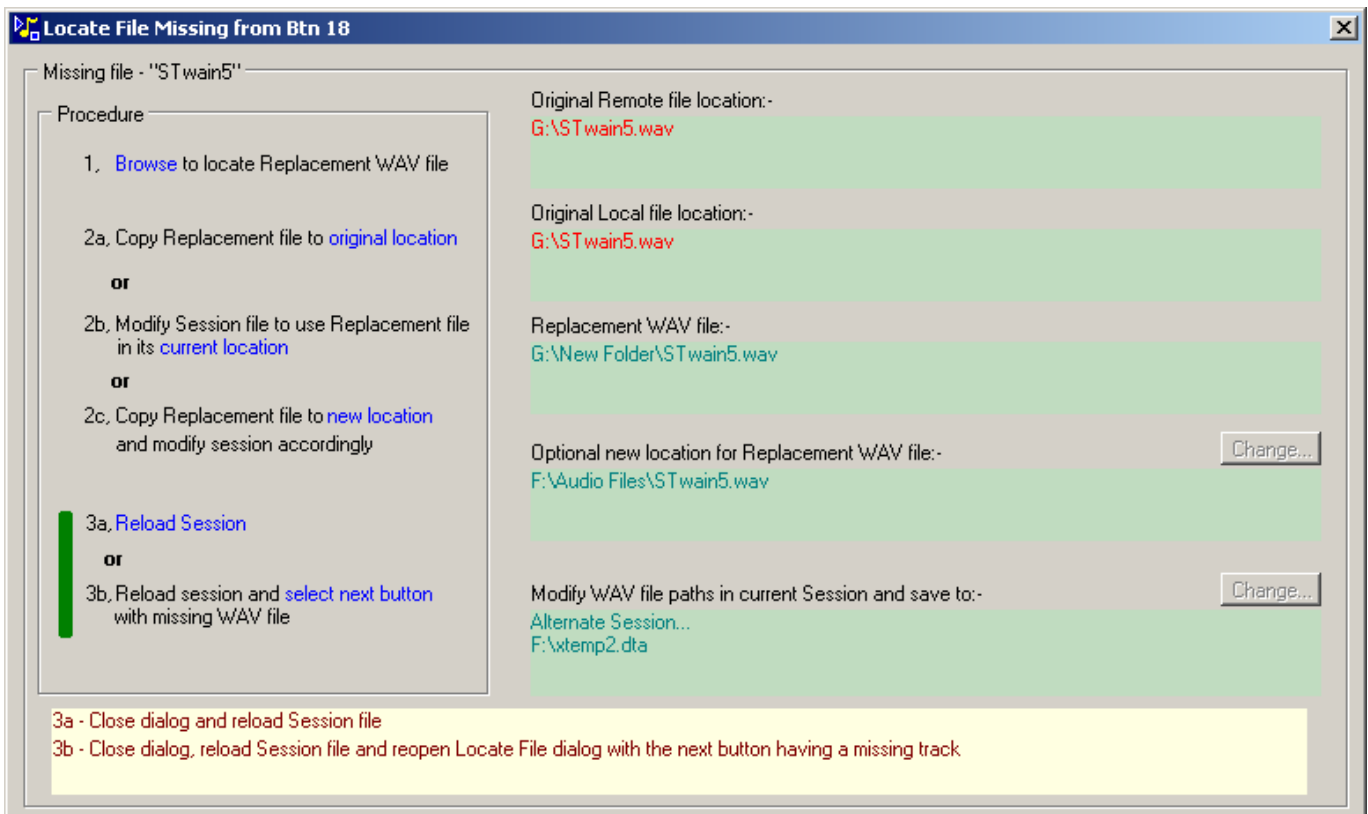

# SetUp Menu

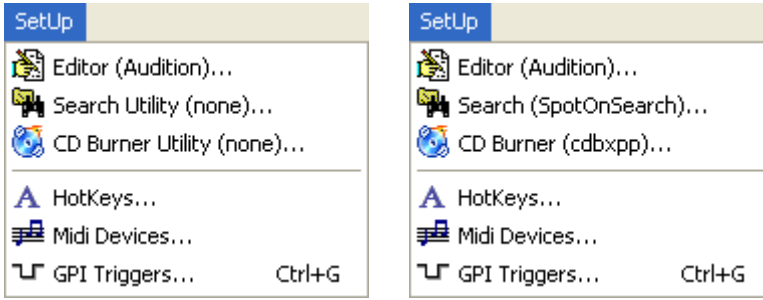

## Editor

Opens a file selector dialog to select an external WAV file editor, the editor application can then be called via the Edit option in the [Button Menu](#), the current editor name is shown in the menu item, a user selected editor is saved within the session file.

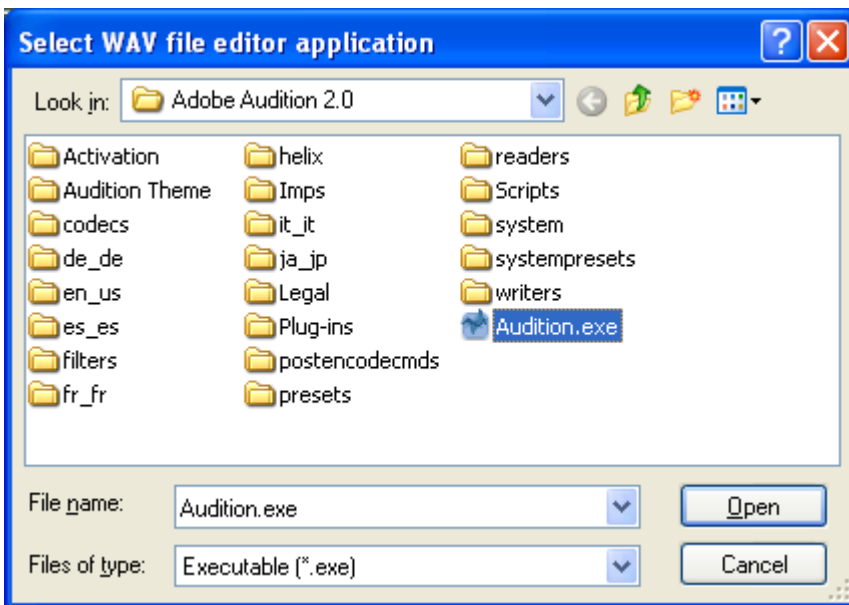

Selecting Cancel from the Editor select dialog will offer the option to clear the existing selection.

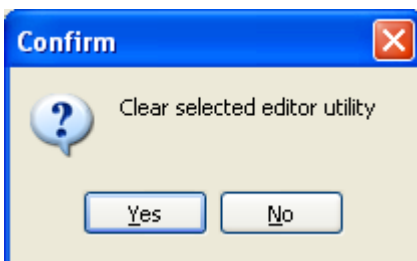

## Search

Opens a file selector dialog to select an external file search utility, the utility can then be called via the Search option in the [File Menu](#), the name of the current search utility is shown in the menu item. A utility [SpotOnSearch](#) is packaged with the SpotOn for this purpose.

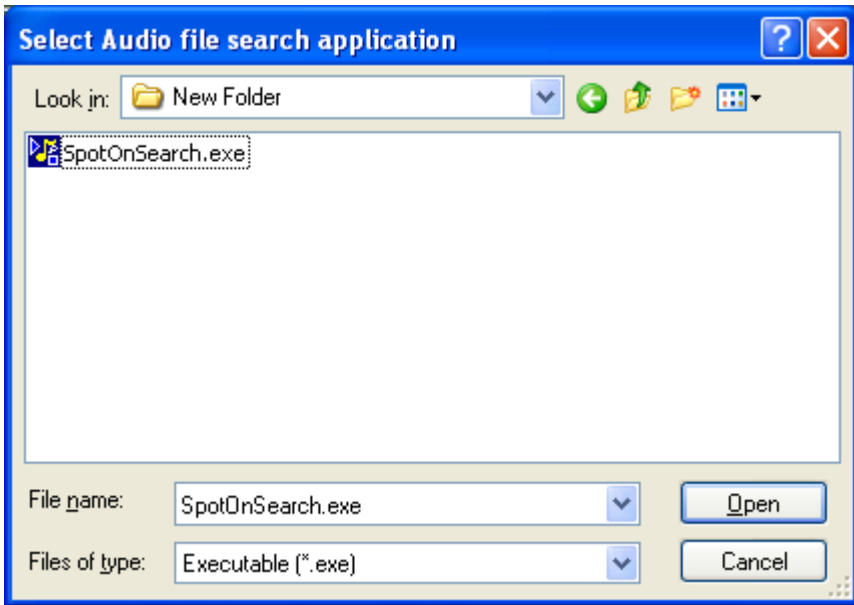

Selecting Cancel from the Search select dialog will offer the option to clear the existing selection.

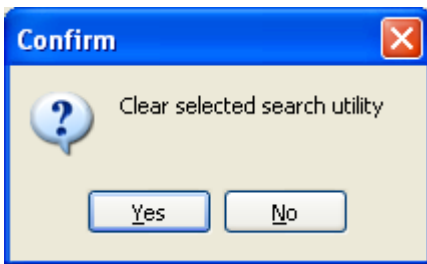

## CD Burner

Opens a file selector dialog to select an external CD Burner utility. SpotOn is configured to use a third party CD burner utility "CDBurnerXP", the latest version of which can be found at <http://www.cdburnerxp.se>. The utility can then be called via Ctrl+B or the CD Burner option in the [Global|Utilities](#) menu, the name of the current utility is shown in the SetUp menu item shown above.

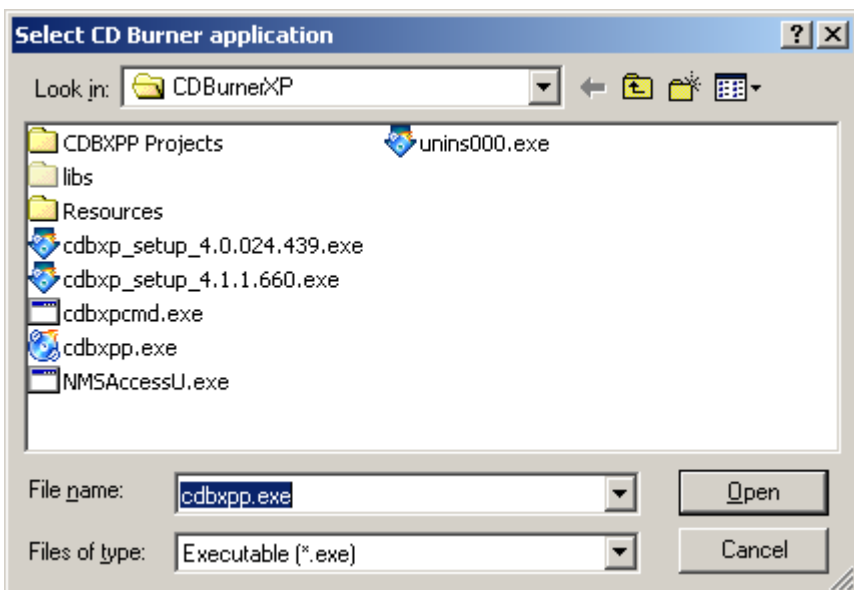

Selecting Cancel from the CD Burner select dialog will offer the option to clear the existing selection.

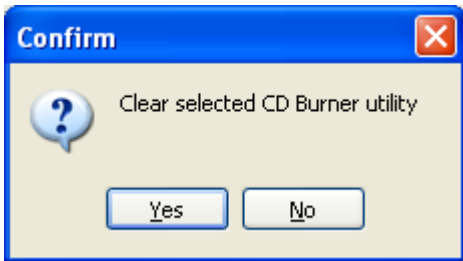

## HotKeys

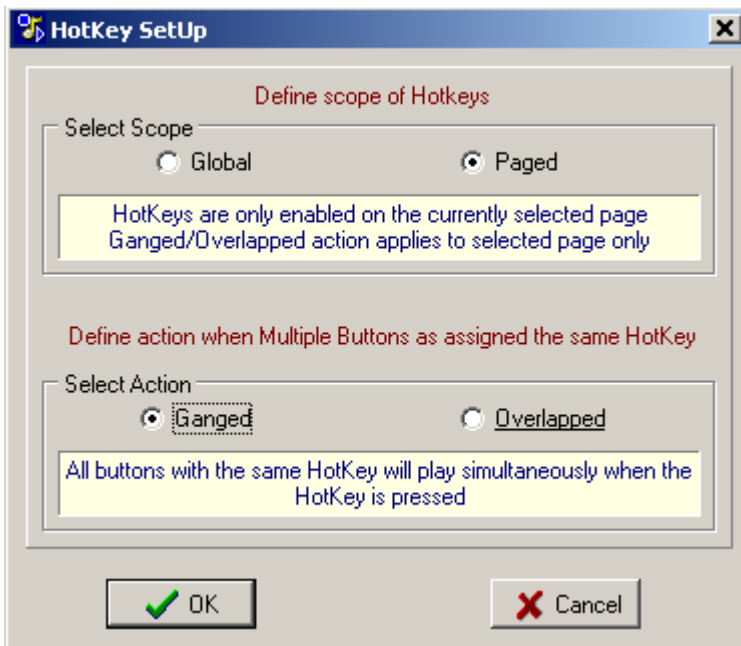

The action of pressing HotKeys can be handled in different ways.

The top selection in the setup dialog box Global/Paged defines the scope of the HotKeys, defining whether the HotKey press is restricted to act only on the currently selected page or applied to all pages globally.

The Ganged/Overlapped setting defines how buttons assigned to the same HotKey should act when the HotKey is pressed.

In Ganged mode all the buttons with the same HotKey will act together, alternatively in Overlapped mode the buttons with the same Hotkey will play in numerical sequence, starting with the first button not currently playing or with the least amount of time remaining if all buttons with the same HotKey are already playing.

Hotkey overlapped play action can also be triggered by a mouse left-click on a button, [see Advanced Operation](#) for further explanation

If the HotKeys are currently disabled then the message below will be shown.



## Midi Devices

The Midi In and Out ports are set using the dialog box below, these are set globally and are not saved in the individual session data files.

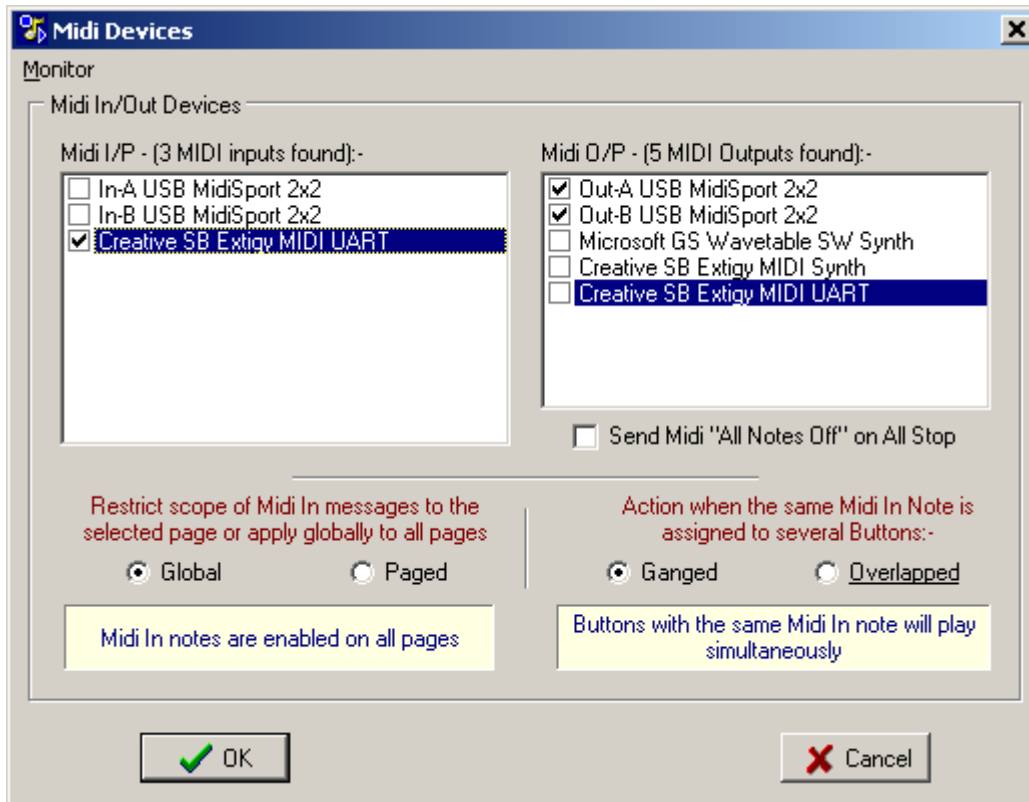

One or more Midi In devices can be selected along with multiple Midi out devices.

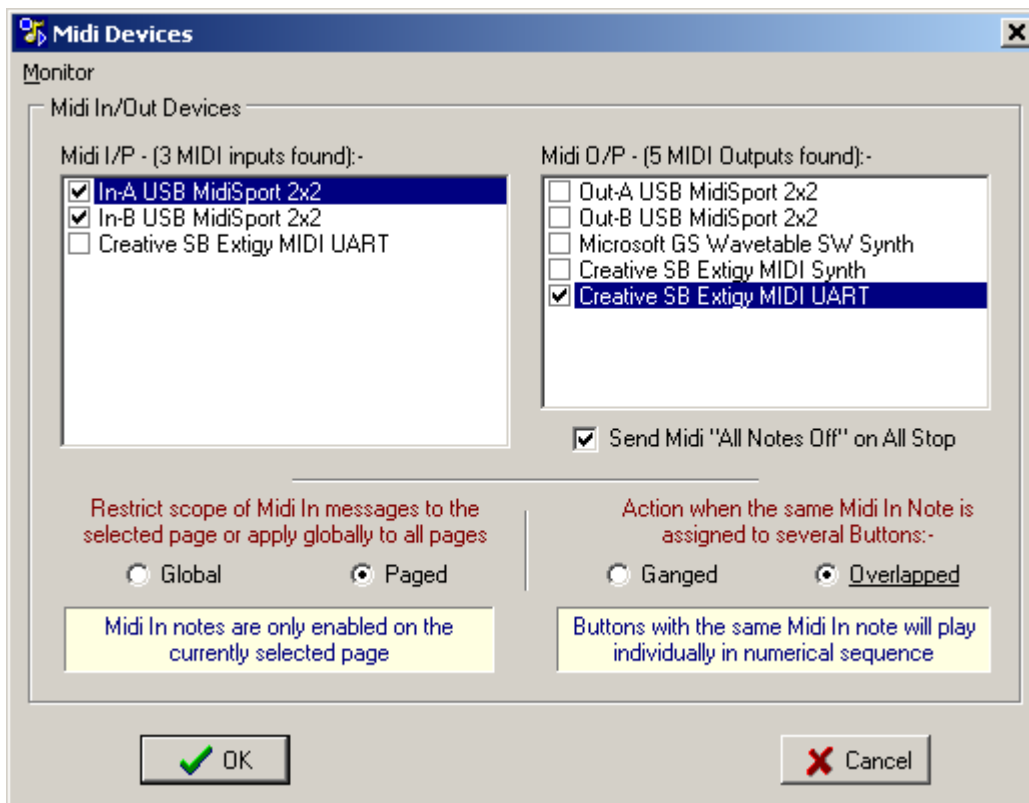

If either the Midi In or Midi Out options are disabled then a message will be shown at the bottom of the dialog box



There is also an option to send the Midi message "All Notes Off" to all Midi Out channels when Escape or All Stop buttons are pressed

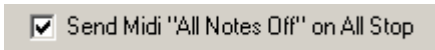

The action of the Midi In notes can be restricted to act only on the currently selected page by selecting Paged option as shown below. Midi In notes can be set to act across all pages by selecting the Global option.

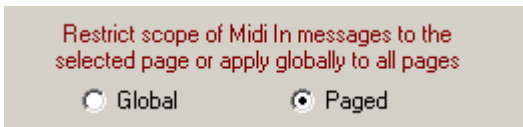

When more than one button is assigned the same Midi note the buttons can be played in one of two ways, Ganged or Overlapped (duplicate hotkey assignments operate in a similar way).

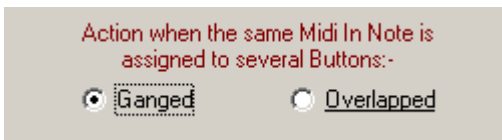

In Ganged mode all buttons with the same Midi In note will play when that Midi In message is received.

Alternatively in Overlapped mode each button with the same Midi In note will play individually on each successive Midi In message. The order in which the buttons are played is numeric starting with the first button not already playing.

The Overlapped mode is suited to effects that need to be repeated but have a long reverberation time, just stopping and restarting the audio would be incorrect, so in Overlapped mode the previous effect is left running whilst a new copy of the effect is played out.

The Midi Note text displayed on the buttons will be underlined if it forms part of an overlapped sequence.

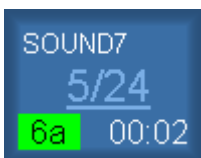

See [Advanced Operation](#) for further explanation

Selecting the Monitor menu item from the Midi devices window displays a listing the timestamped incoming midi messages. If Midi timecode is detected it will be shown at the top of the window in green text, if no Midi timecode is present the text will be in red. Midi timecode is also displayed in the [Data Rate panel](#) on the main window status bar.

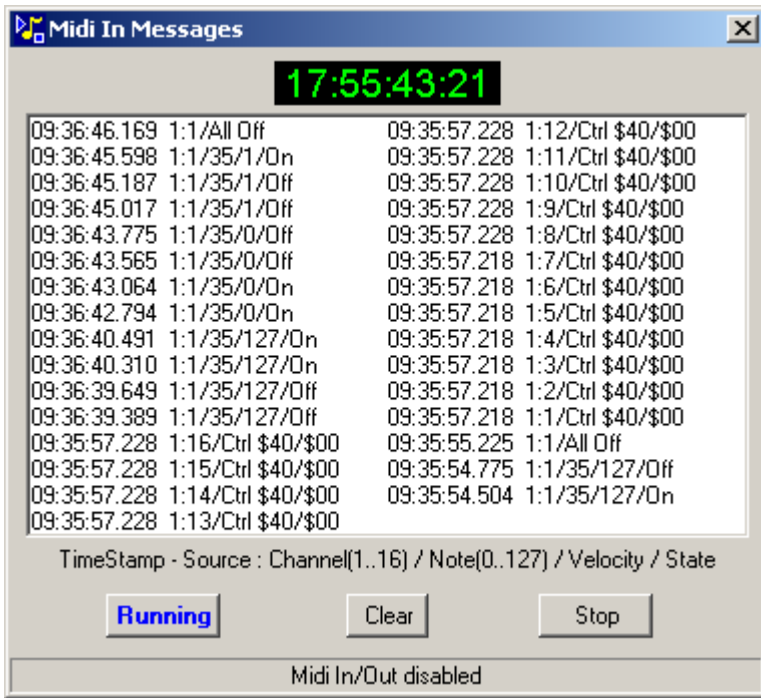

The most recent Midi messages are shown at the top of the list, the Run and Stop buttons control the logging of the messages, clear will delete all entries in the list.

## GPI Triggers

External GPIs can be used via the computer game port to trigger playing of buttons see [GPI Assignments](#) this menu item can access via the Ctrl+G keyboard shortcut

# GPI Assignments

SpotOn accepts inputs from up to 64 GPIs (General Purpose Interfaces), the first four of these are most simply implemented via the PC Game Port using the joystick button [connections](#). A USB joystick can also be used, however some internal wiring modifications to the joystick will be required to extract the switch contacts.

Any joysticks detected as being connected to the computer when SpotOn was run will be shown in the drop down list.

A PC Game Port card can be used to provide GPI inputs 1..4, with GPIs 5..64 typically triggered by Hotkey, Midi or time based emulation of GPIs - see later.

## Joystick Selection

In the image below only one joystick was found and it has 4 buttons that can be used, these are assigned to GPI 1..4, "LEDs" for the remaining GPIs are shown in grey.

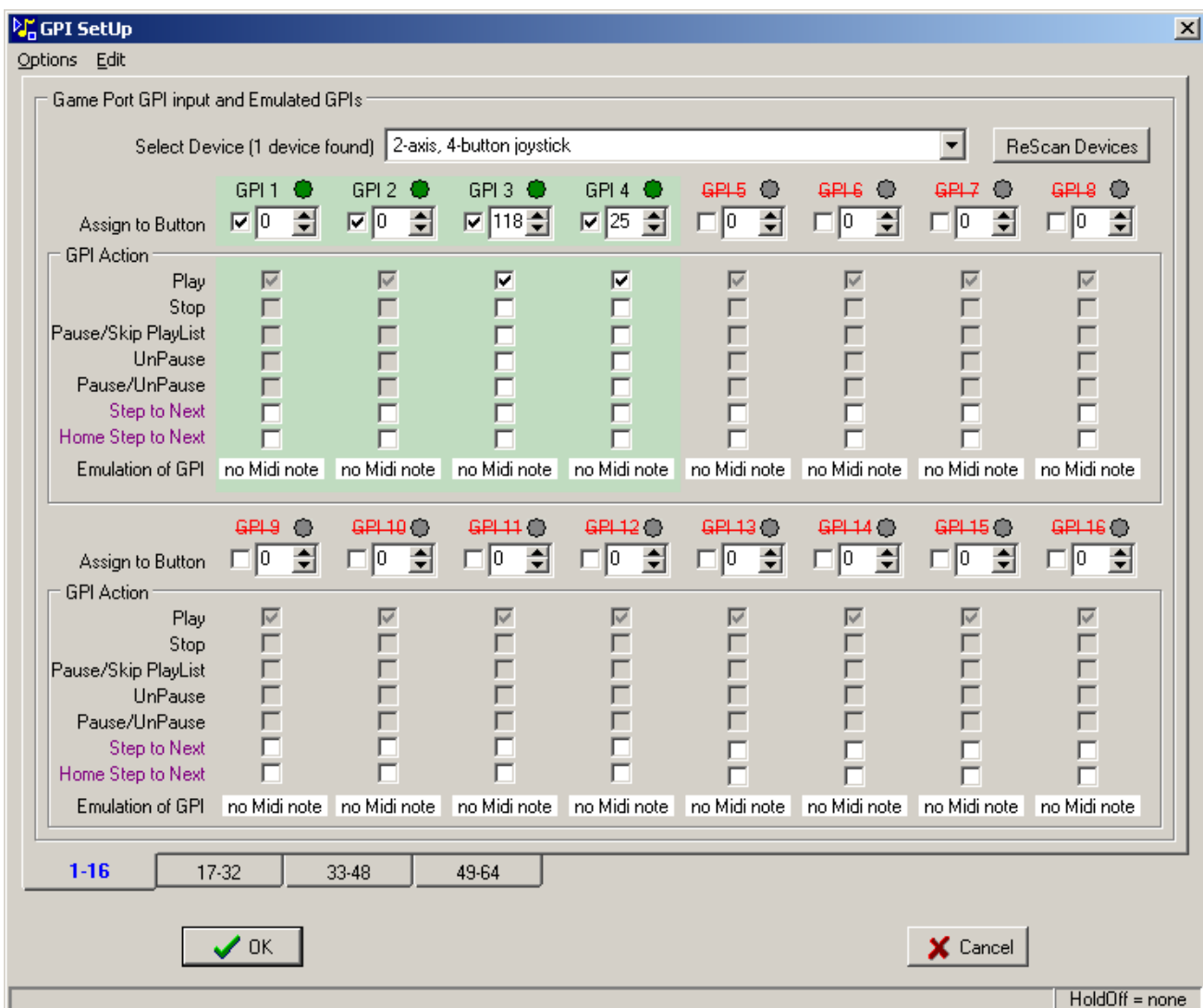

The area with a green background indicates that only GPI 1..4 can be 'real' GPIs from a game port card, the other GPIs will be emulated in some way.

If more than one joystick device was detected then they will appear in the drop down list



If the configuration of the GPI devices has changed the list can be refreshed by clicking on the ReScan Devices button which will clear the selection and fill the list with the devices currently connected.

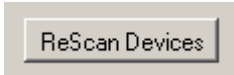

If a GPI device (joystick) is disconnected whilst in use then the display will show something like this



If GPIs are enabled the status bar of the main window will also indicate a disconnected device by flashing the GPI panel black/white



Disconnecting the GPI lead from the computer whilst SpotOn has it selected is not recommended, the GPI device should be deselected before it is unplugged, see [GPI wiring suggestions](#).

The next image shows the result when a 4 button joystick is detected, the red text in the GPI 1 box indicates that value (button number) has been changed since the dialog box was opened and hence is not a true mimic of the actual GPI assignment

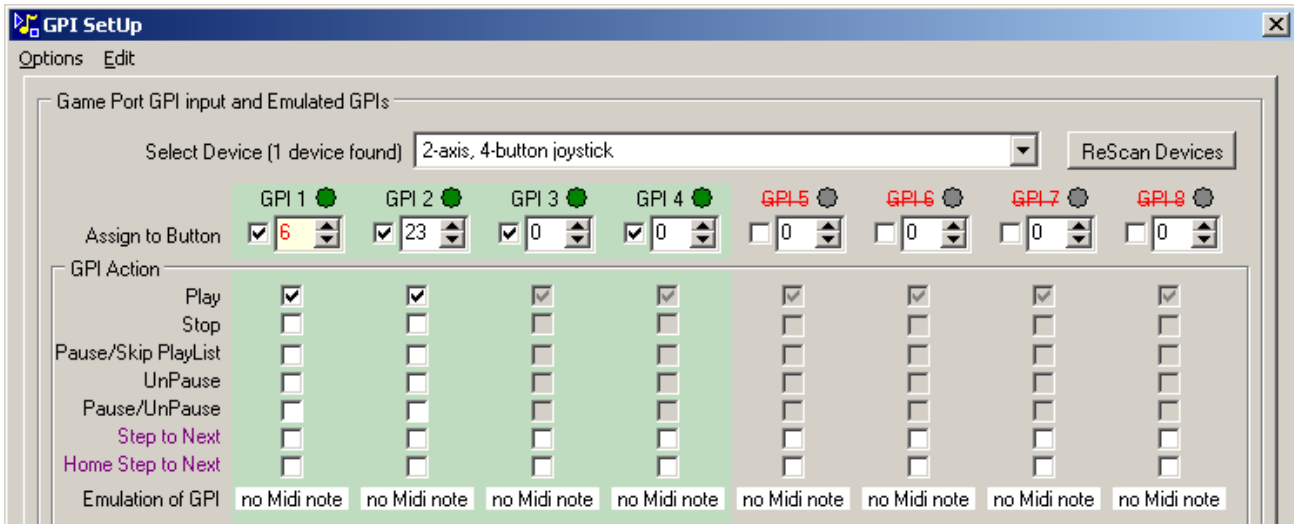

The checkboxes immediately to the left of the GPI button number allow the GPI to be enabled/disabled, in the disabled mode the display is as shown below.



The devices connected to the game port are only checked when SpotOn starts up, if there are any changes to the attached devices then the ReScan Devices button must be clicked or SpotOn restarted before they are registered.

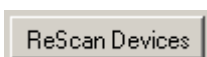

The choice of joystick device is applied globally and is not saved in the individual session data files.

If the GPI In triggers are disabled via the GPI In On/Off menu option then the message below will be shown.



## Button to GPI Assignment

The up/down nudge buttons associated with the GPI channels assign the button that will be controlled when the GPI becomes active, a button value of zero disables that GPI channel from controlling a specific button.

Under the nudge buttons are seven rows of checkboxes - Play, Stop, Pause, UnPause, Pause/UnPause, Step to Next and Home Step to Next.

Row 1 is the default action of Playing a track when the GPI becomes active.

Row 2 can be set to Stop a track when the GPI becomes active.

Row 3 can be set to temporarily Pause a track when the GPI becomes active, the Pause action is not available when the button has an active PlayList so this item will trigger a [Skip PlayList item](#) operation

Row 4 similarly will release the Pause and continue playing the track from the point it was paused.

Row 5 allows a single GPI to alternately Pause and UnPause a track

Row 6 enables the Step to Next Track function see [Options|Step To Next Track](#), if selected the GPI will issue a Play command to successive buttons each time it becomes active, (an option to skip over muted buttons is available under Options menu).

Row 7 of checkboxes provides the facility to reset the Step to Next operation by forcing the next button to be played to be the top left button on the current page, equivalent to pressing the Home key on the keyboard.

Note that when both Step to Next and Home Step to Next are checked SpotOn will first Home the selection to the top left button and then play that track and step to the next button.

In the example below GPI 1 will play successive buttons and GPI 2 will reset the next button to be the top left button.

Selecting any Step to Next checkbox will automatically set the GPI button value to zero.

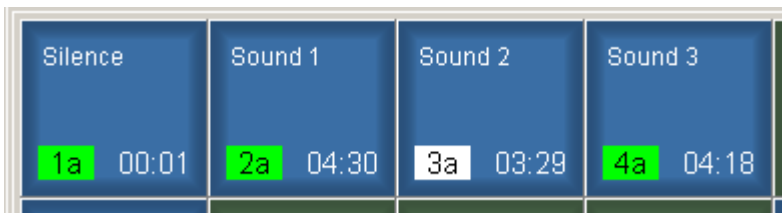
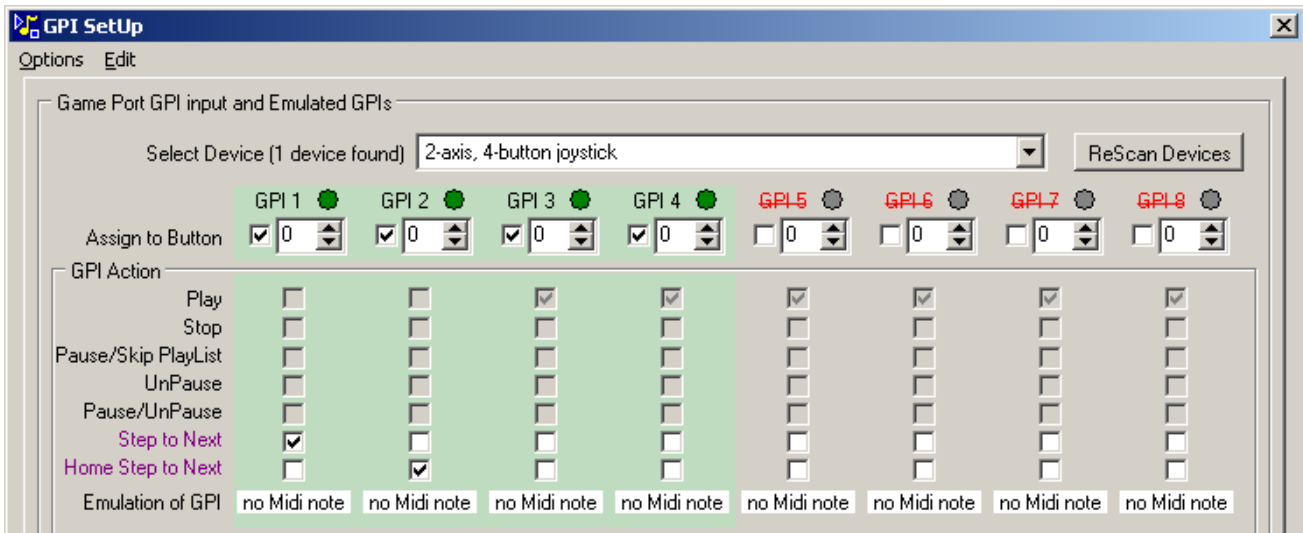

In this case if GPI 1 is asserted "Sound 2" will play and then SpotOn will step to button 4 ready to play "Sound 3"

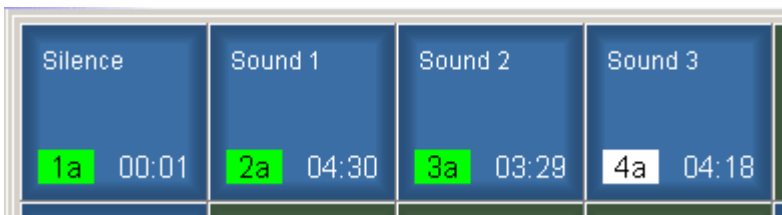

If GPI 2 is now asserted the Step to Next sequence will be reset to select button 1 which could well be a silent button that stopped all others, allowing the sequence to be reset at any time.

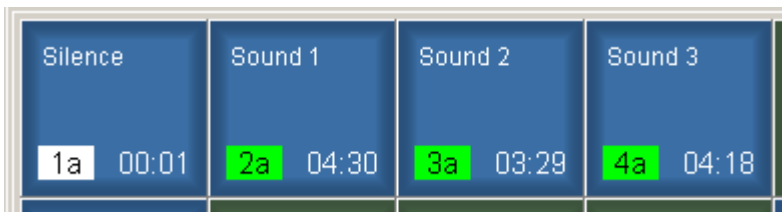

## Emulation of GPI



Using the emulation selection boxes, a match to Hotkey, PC clock time, incoming Midi note, Midi timecode or a source of SMPTE timecode can be used instead of an external GPI to trigger the GPI action, right-click the selection box for options

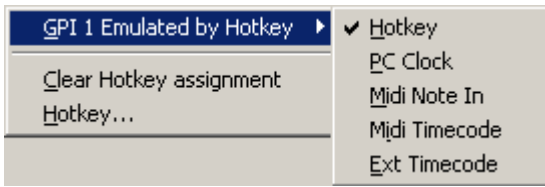

### Emulation of GPI by Hotkey

Assign the Hotkey to the GPI by pressing the appropriate keyboard key

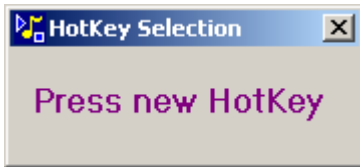

The image below shows Hotkeys Q, W, E assigned to GPIs 1..3

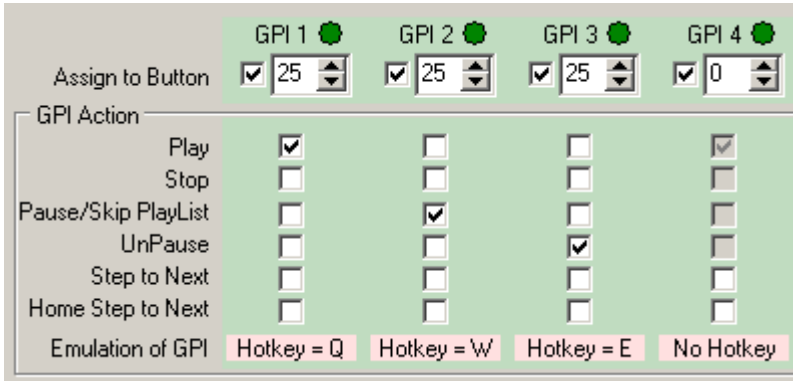

The same Hotkey can be assigned to button and to a GPI emulation

### Emulation of GPI by PC Clock

The PC internal clock can also be used to trigger GPI actions

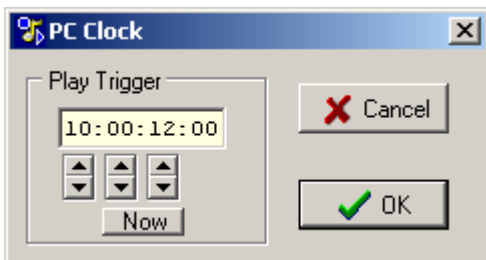

the precision of the time setting is restricted to 1 second for the PC clock source, the "Now" button is enabled in this mode to allow quick entry of the current time of day.

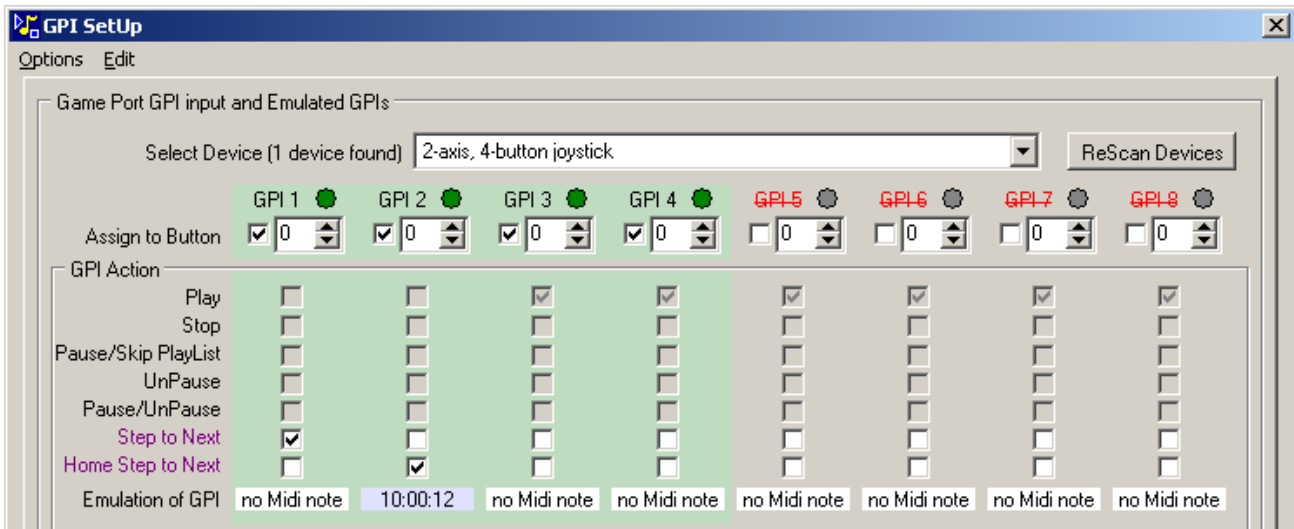

## Emulation of GPI by Midi Note

Select Midi Note In to display a Midi Note dialog box.

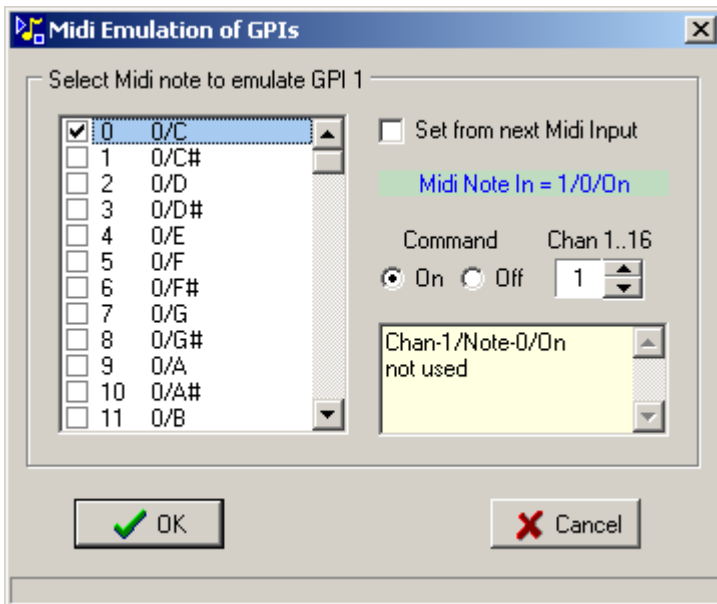

The Midi note can be automatically assigned by checking the box shown below, this will set the Midi note from the next Midi note to be received by SpotOn.

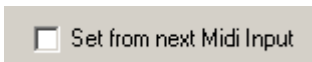

Here the Note On message for note 60 on channel 9 has been selected to emulate GPI 2

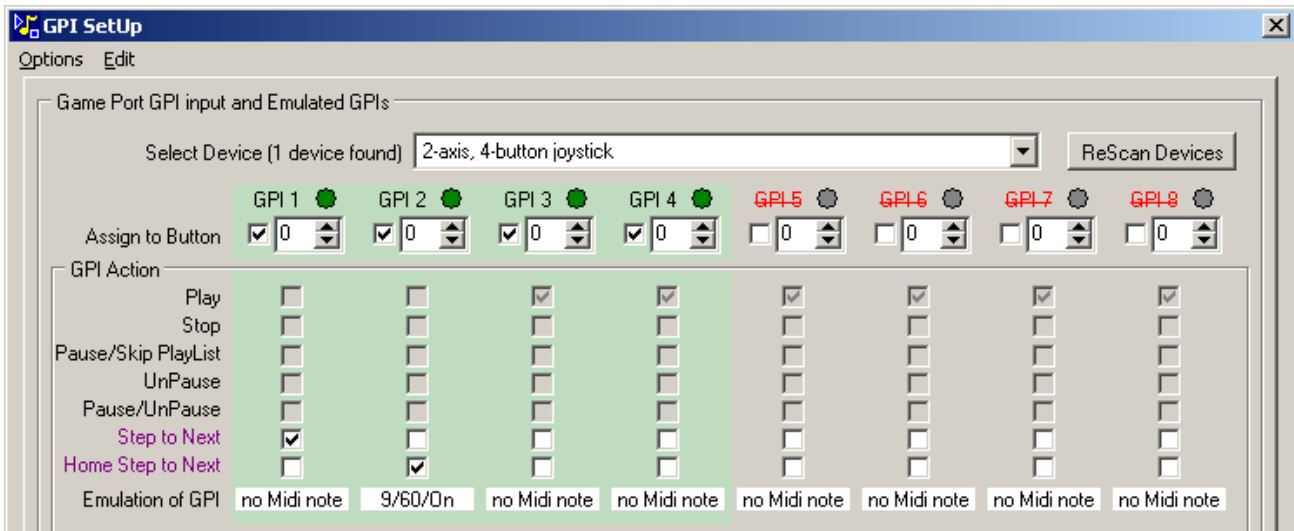

Now the selected Midi note will cause the GPI 2 action to be performed.

### Emulation of GPI by Midi Timecode

The fourth option is to trigger from a Midi timecode stream

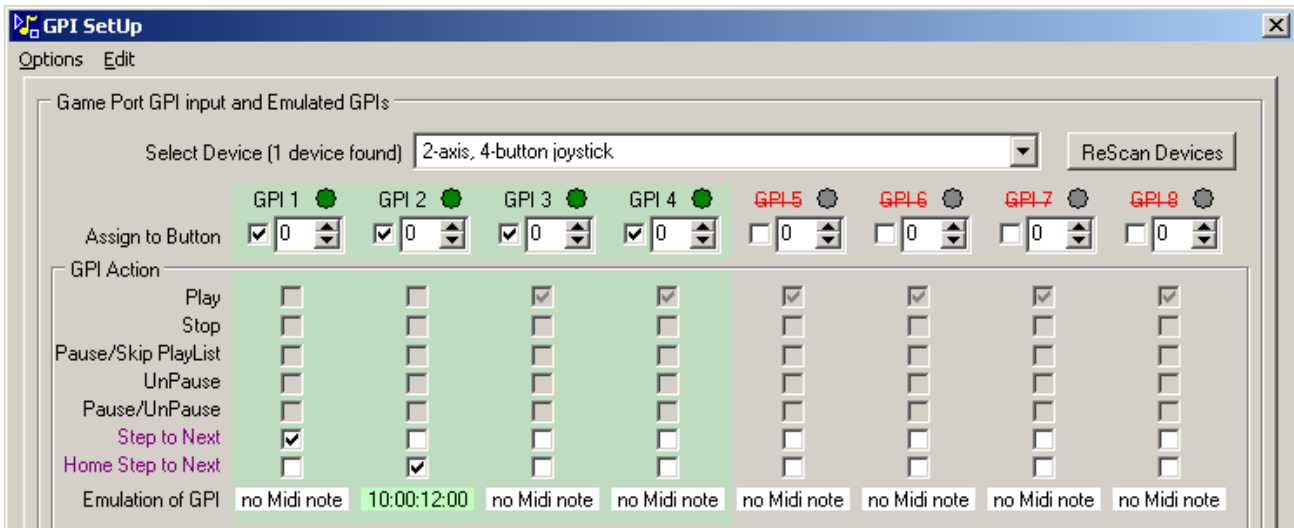
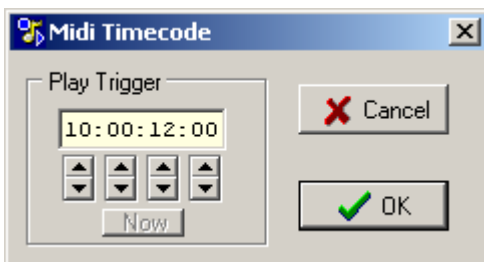

When any GPI with a time related trigger mode (PC Clock, Midi timecode or SMPTE timecode) is enabled and GPIs are enabled globally then the GPI In status panel background will flash to red whilst SpotOn is armed waiting for the time trigger.



Immediately after the time related GPI is triggered the associated GPI will be disabled to avoid subsequent false triggering.



When any GPI with a time related trigger mode (PC Clock, Midi timecode or SMPTE timecode) is enabled and GPIs are enabled globally then the GPI In status panel background will flash to red whilst SpotOn is armed waiting for the time trigger.



Immediately after the time related GPI is triggered the associated GPI will be disabled to avoid subsequent false triggering.

As an alternative triggering mode the GPI can be rearmed when the detected timecode is earlier than that set as the trigger point, this is selected via the right-click pop menu item Auto Arm Timecode

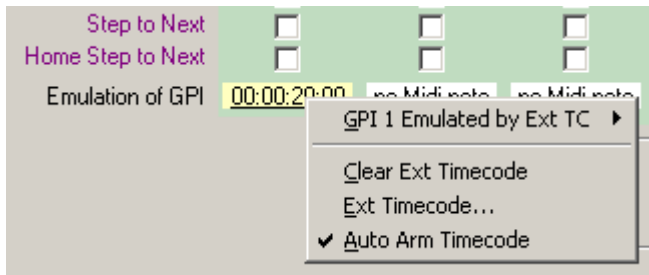

To indicate the GPI is in the Auto Arm mode the Midi timecode value is shown underlined.

The Auto Arming function can be disabled for all GPIs via the Options|Auto Arm Ext/Midi Timecode GPIs main menu option.

When the Auto Arming is disabled the associated popup menu item will be greyed out

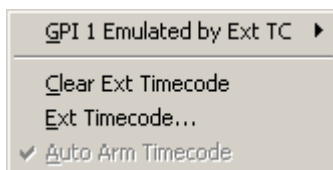

SMPTE timecode nudge:-

A hotkey shortcut is available to nudge the SMPTE timecode settings by shift+right clicking on the GPI In panel on the status bar.

The popup menu shows the last adjustment made along with options to nudge the trigger point earlier or later

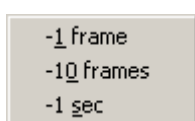
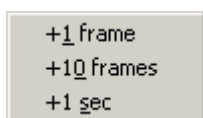
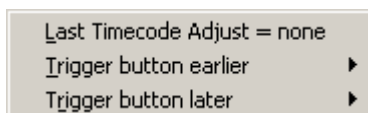

## GPI Indication

When a GPI channel is active then the LED will change to show red

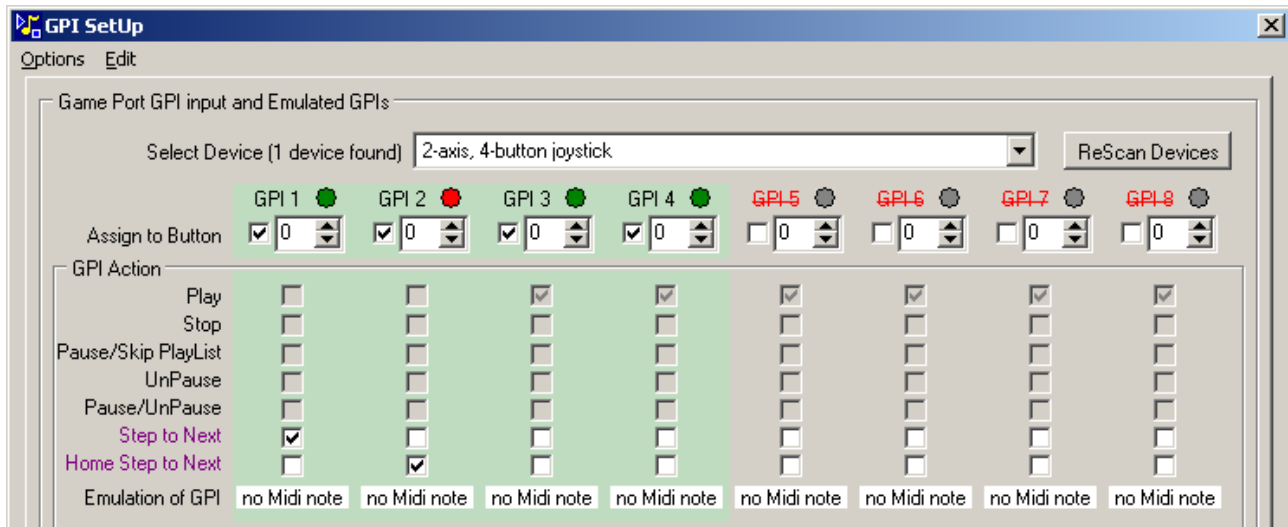

The GPIs can be globally enabled/disabled via the main menu [Options|Use GPI In](#) item and also by clicking the main window status bar panel



The text in the main window status panel briefly flashes red when an incoming GPI is detected

## Menus-Options

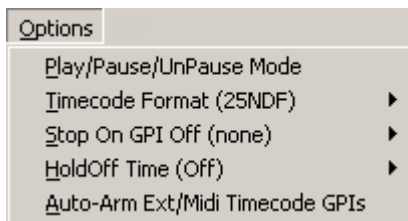

### Play/Pause/UnPause

Checking the Play/Pause/UnPause option will change the default Pause/UnPause action to be Play/Pause/UnPause and the screen legends will follow accordingly.



When Pause/UnPause is selected as a GPI action, successive GPI pulses will alternately Pause and UnPause a playing track, however if the track is neither Playing or Paused then the GPI is ignored.

With Play/Pause/UnPause checked in addition to the action described above the track will begin Playing if a GPI pulse is detected when the track is stopped i.e. not Paused and not Playing.

So the sequence of events could be GPI pulse 1 = Play, GPI pulse 2 = Pause, GPI pulse 3 = UnPause.

## Timecode Format



The timecode received by SpotOn either via Midi or external SMPTE inputs and used to trigger GPIs can be one of a variety of frame rates:-

24NDF	24Hz non-drop frame
25NDF	25Hz non-drop frame
30NDF	30Hz non-drop frame
29.97DF	29.97Hz drop frame

Selecting the appropriate format changes the timecode display and editing dialog boxes.

## Stop on GPI Off

Normally the assertion/closure/forcing low of the GPI input is the only transition recognised and will Play the assigned button, if the menu option StoponGPIOff is selected then the off transition of the GPI is also detected and will Stop playout of the assigned button. GPI 1..4 can be individually set to react to the GPI off state.

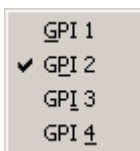

## HoldOff

As it is likely that the source of the GPI signal will be a manually operated switch, there is the chance that the switch contacts will bounce so sending unwanted signals. To avoid this there is a selectable HoldOff period under menu Options|HoldOff Time

The range of HoldOff is 0..5 seconds

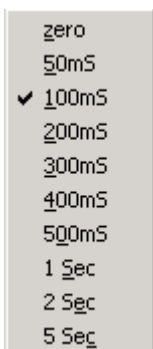

The currently selected HoldOff period is shown in the right hand panel of the status bar and applies to all GPI channels

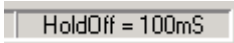
A rectangular status bar with a light gray background and a thin border. The text "HoldOff = 100mS" is centered in a dark gray font.

### AutoArm

Auto-Arm Midi timecode GPIs - this is a master enable for all the GPIs emulated by Midi timecode, a warning will be shown in the lower part of the window when this option is active.

A rectangular warning box with a light gray background and a thin border. The text "Midi Timecode GPIs Auto Armed" is centered in a red font.

When this option is checked, any GPI set to trigger from a Midi timecode and individually AutoArmed, will be re-armed when the timecode value detected is earlier than the trigger timecode.

This mode allows multiple passes without the need to arm/enable the GPIs on each pass.

### **Menus-Edit**

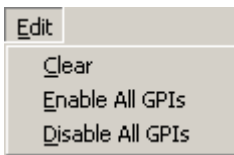
A screenshot of a menu titled "Edit". The menu is open, showing three options: "Clear", "Enable All GPIs", and "Disable All GPIs". Each option has a small icon to its left.

The Edit menu contains three items:-

- a, clear all the GPI button assignments
- b, set all GPIs enabled
- c, set all GPIs disabled

On exiting the GPI Setup dialog a message box will appear warning of any Hotkeys that are assigned directly to Buttons and also selected as GPI emulation triggers.

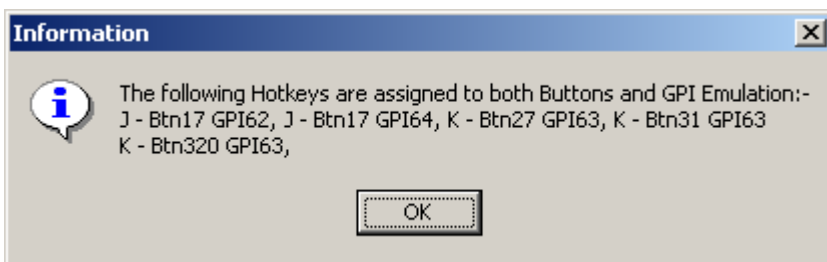
A screenshot of an "Information" message box. The title bar is blue with the word "Information" in white. The main area has a light gray background. On the left is a blue speech bubble icon with a white "i". To the right of the icon, the text reads: "The following Hotkeys are assigned to both Buttons and GPI Emulation:- J - Btn17 GPI62, J - Btn17 GPI64, K - Btn27 GPI63, K - Btn31 GPI63 K - Btn320 GPI63,". At the bottom center is a button with the text "OK".

## Display

If the main menu [Display>Show GPI In Icons](#) option is checked then buttons assigned a GPI will have a diamond shape on the centre left of the button image.

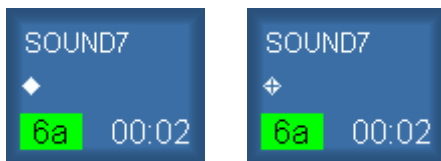

This diamond shape will have an internal + sign if more than one GPI is controlling a specific button

# Display Menu

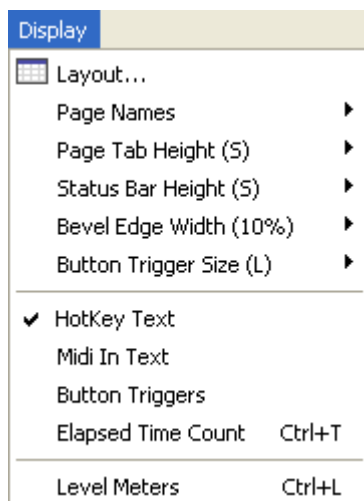

## Layout

SpotOn can display the buttons in a number of different configurations ranging from 8 pages with 1 button per page to 160 buttons per page across 2 pages.

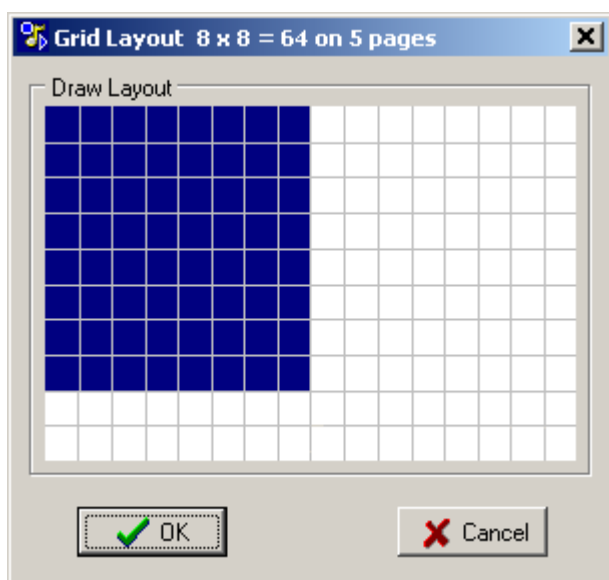

Use mouse to drag the layout to the desired configuration

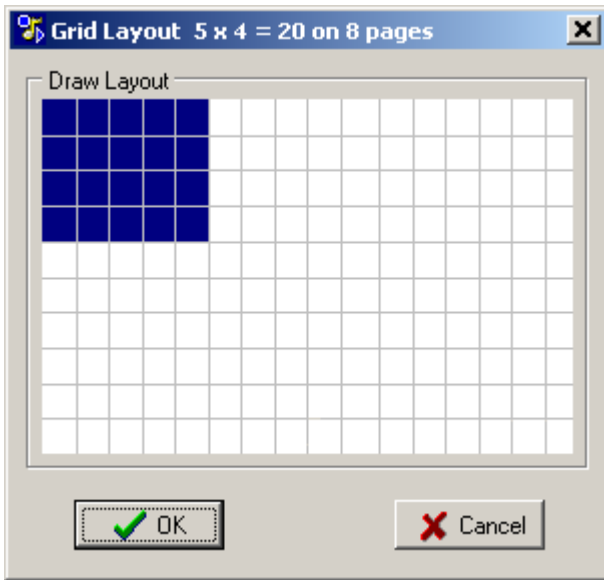

SpotOn has access to maximum of 8 pages of buttons, the number of pages actually available depends on how many buttons per page are displayed.

In the case below there were 48 buttons per page over 6 pages giving 288 buttons, pages 7 and 8 are therefore unavailable, buttons in the range 289 to 320 are hidden as they do not form a complete page.

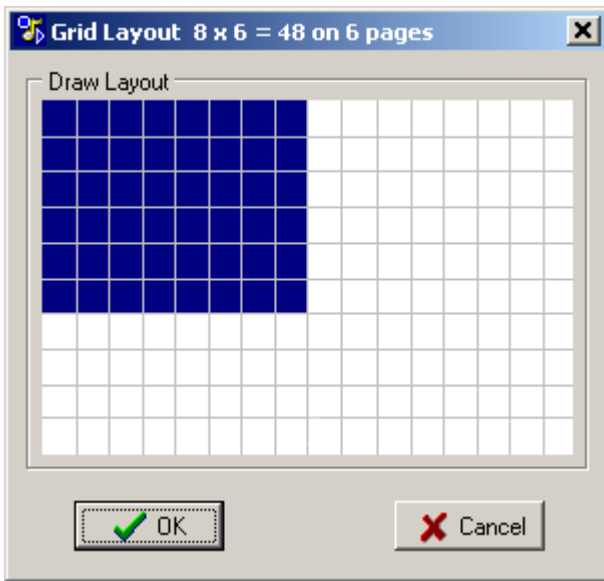

### Page Names

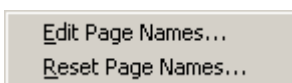

By default the page names are numbers 1..8 these can be changed to something more meaningful, as the size of the page tabs are restricted only short names are suitable

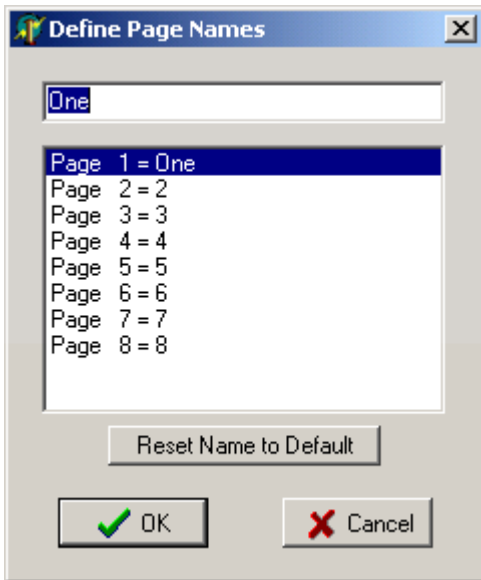

All the page names can be returned to the defaults of 1..8 using the Reset option, a confirmation dialog is shown before the names are changed

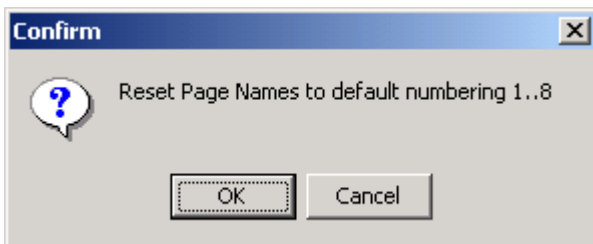

Another method of accessing the page name editor is to right-click the tabs

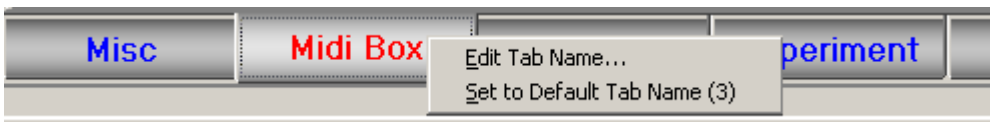

## Page Tab Height

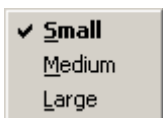

The height of the page tabs at the bottom of the screen can be set to any of three levels

Small:-



Medium:-



Large:-

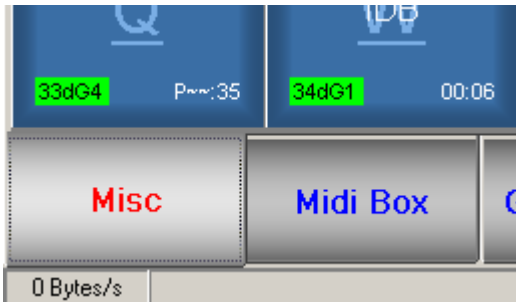

The larger sizes are more suited to operation via a touchscreen, on the Medium and Large settings the tab text will be word wrapped onto two lines



Depending on the width of the tab and the text the word wrapping may or may not be acceptable, however there is a feature that can force text onto the second line.

This is achieved by inserting a caret character '^' into the text at the point where the line break should appear.

(On most UK language keyboards the caret character is usually found as Shift+6)

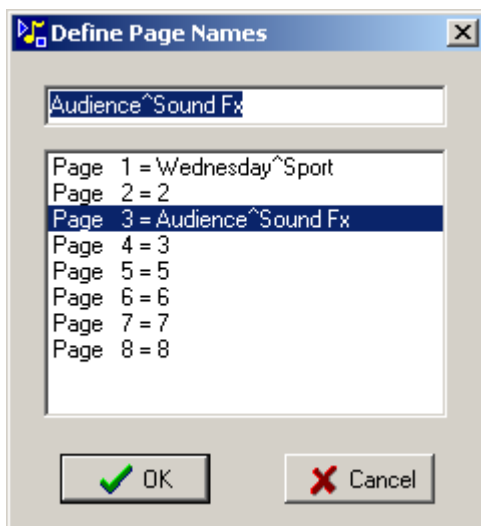

The resultant text is then correctly split over two lines

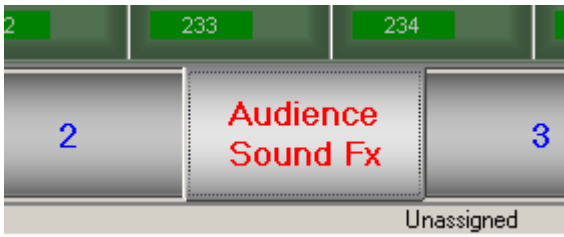

### Status Bar Height

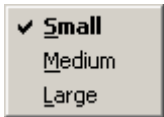

The height of the status bar at the bottom of the screen can be set to any of three levels

Small:-

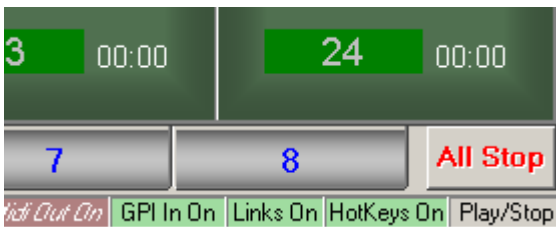

Medium:-

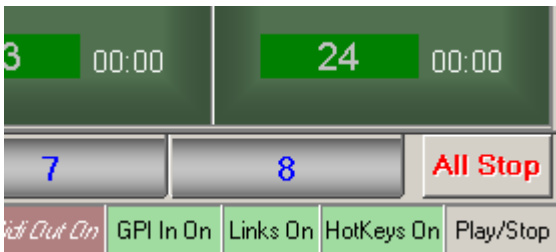

Large:-

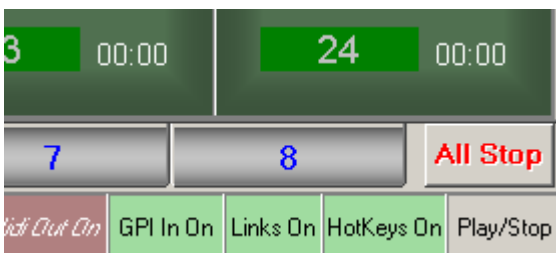

The larger sizes are more suited to operation via a touchscreen.

## Bevel Edge Width

The width of the shaded edge of the buttons can be adjusted with this option

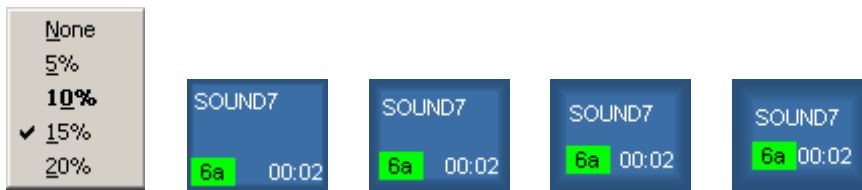

## Button Trigger Size

The size of the graphic appearing on the button can be set to one of three sizes Small, Medium or Large.



## Hotkey Text

If a button has a Hotkey assigned it will normally be shown in dimmed text in the centre of the button, to aid visibility of the track name the hotkey indication can be disabled with this option.

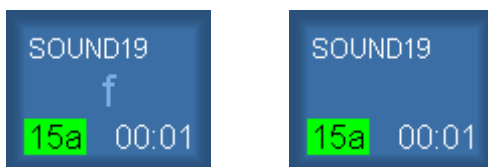

## Midi In Text

As an alternative to the hotkey text display the buttons can show the Midi In Channel/Note assignment.

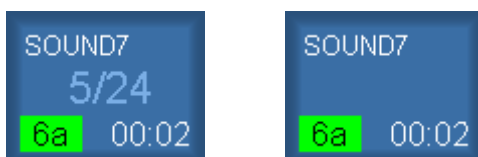

The button text display can be either HotKey, Midi In or none

## Button Triggers

SpotOn buttons can be triggered in a variety of ways, essentially these can be split into two groups:-

Local                    button click, PlayNext, Master/Slave...  
Remote                 GPI, Timecode, Midi...

To aid the operator identifying if particular button was triggered by some type of remote control, a Button Trigger graphic can be displayed on the button.

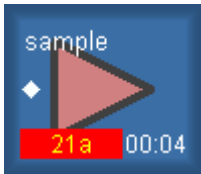

This graphic is shown when the button is triggered by Midi, GPI, UDP, TCP, PBus or Timecode

## Edged Midi/HotKey Text

In order to improve visibility of the button Midi and HotKey text this option will add a drop shadow effect to the text

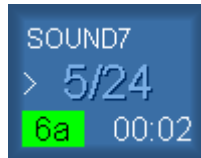
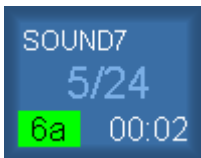

## Elapsed Time Count

By default the display at the lower right of the button shows the time remaining - counting down to zero.

As an alternative the display can be changed to show the Elapsed time - counting up from zero

This option applies globally and has a keyboard shortcut of Ctrl+T

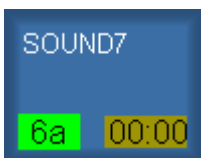

## Level Meters

A window showing the signal level on the first 4 outputs can be displayed with this menu item or via the Ctrl+L keyboard shortcut.

The buttons playing on specific outputs are listed in numerical order up to a maximum of 3, the text is coloured according to the number of buttons contributing to the output.

Green            One button playing  
Yellow          Two buttons playing  
Red             Three or more buttons playing

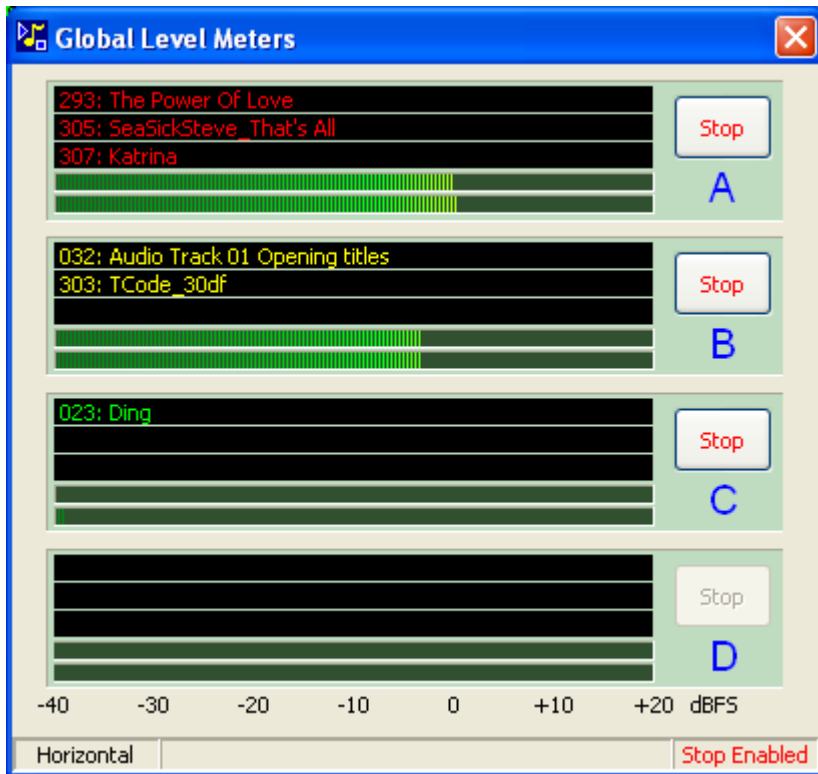

The Stop buttons on the right of the window allow all buttons on those specific outputs to be stopped, the Stop buttons are enabled by clicking the bottom right status bar panel



Individual buttons can be stopped by right-clicking on the appropriate entry

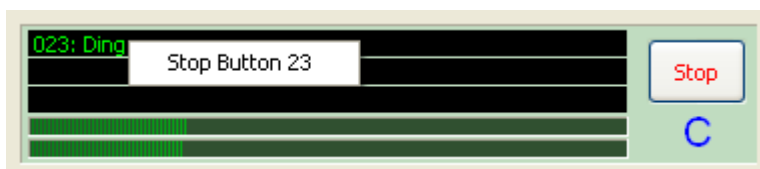

Right-clicking on the output letter "C" offers a timestamped listing of the last 100 tracks played on that output

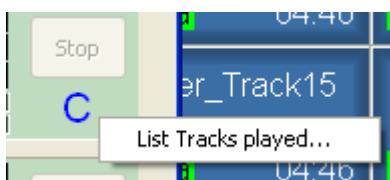

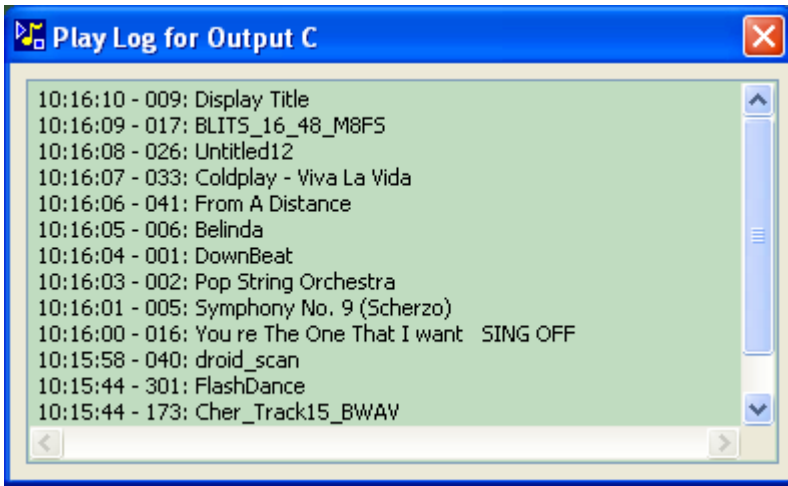

An alternative vertical Level Meter display is available by left clicking the lower left status bar panel on the Level Meter window.

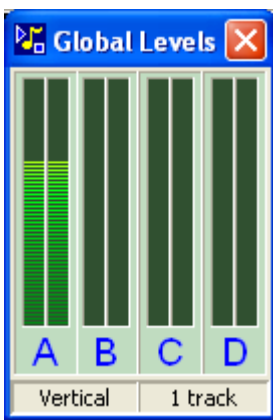

This simple display mode does not list the track names, but the number of tracks contributing to an output can be found by moving the mouse pointer over the output bargraphs.

The right-click option to show the list of recent tracks played on a specific output is still available in this mode.

### Timecode Display

A floating window showing currently selected timecode reference



# Edit Menu

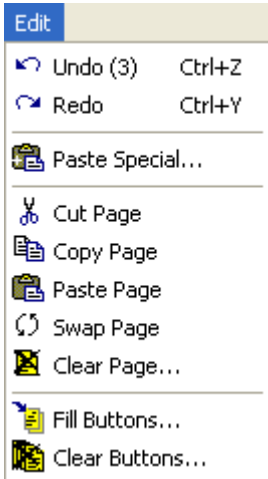

Undo	Undo last change
Redo	Redo last Undo
<a href="#">Paste Special</a>	Selectively paste button parameters
Cut Page	Copy current page to clipboard and then clear current page
Copy Page	Copy current page to clipboard
Paste Page	Paste clipboard contents onto current page
Swap Page	Exchange page contents of current page with those last copied to clipboard
Clear Page	Clear contents of current page
<a href="#">Fill Buttons</a>	Load a sequence of buttons with the same audio file
<a href="#">Clear Buttons</a>	Clear all buttons

## Paste Special

The Paste Special option available at both button and page level can be used to copy/paste certain parameters from one button to one or more other buttons.

First the source button is selected that has the parameters to be pasted and the button is copied to the clipboard using the button popup menu Copy item

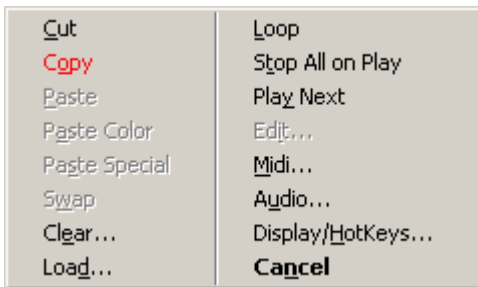

The main menu Edit|Paste Special dialog allows the selection of the parameters to be pasted, below Pan, Midi Out, Fade Out and Colour have been chosen, the Fade law checkbox is automatically checked when a fade time is selected.

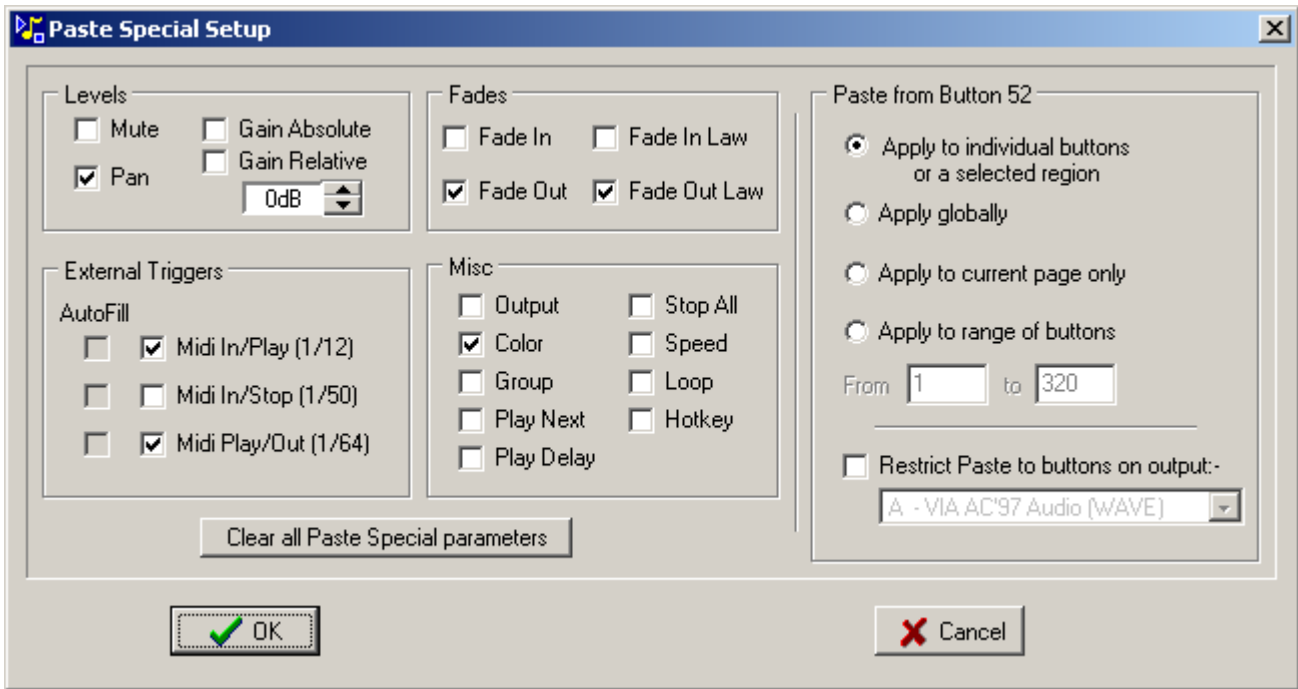

On the right hand side of the dialog is the section where the range of target buttons are defined, the default is single individual buttons.

The parameters can now be pasted onto existing buttons using the button popup menu Paste Special option



The status bar hint will indicate which parameters will be pasted, in this case Pan, Fade Out duration, Midi In to play and Color have been selected.



If a gain adjustment is required to be applied to several buttons and their relative gain settings must be maintained, then the Gain Relative option should be used, in the example below the gain of each button on which Paste Special is used will be increased by 3dB.

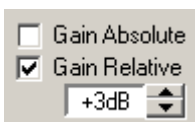

If more than one consecutive button is to be modified then other Paste Scope options can be used

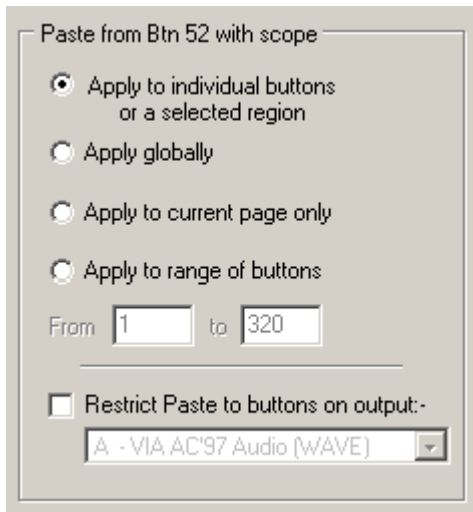

- 1, One individual button at a time
- 2, All buttons across all pages
- 3, All buttons on current page only
- 4, A defined range of buttons
- 5, Further restrict above selection to only act on buttons assigned to a specific output

If a range of buttons 10..18 is required then the entry will look as below

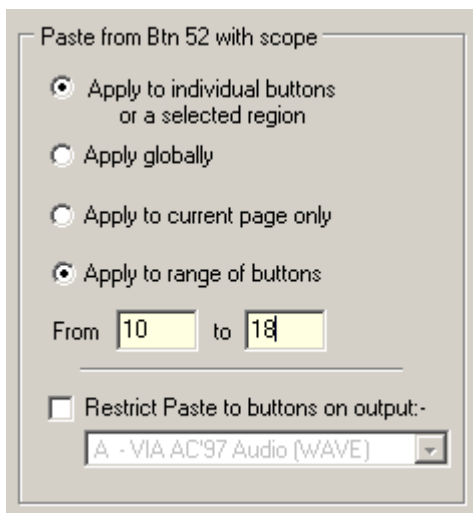

When the Paste Special dialog is exited a further confirmation dialog will be shown with a summary of the changes about to be applied

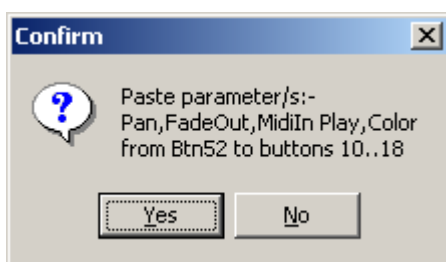

Midi In/Play, Midi In/Stop and Midi Play/Out paste options have 'AutoFill' modifiers, when checked these will fill the selected range of buttons with a Midi note based on that of the copied button.



The Auto Fill modifier is only enabled when Paste Midi In/Play, Midi In/Stop or Midi Play/Out are checked and the Paste Scope is set to be a range of buttons



Pasting a range of buttons with Auto Fill checked will set the Midi notes of the pasted buttons to:-

Midi Note of copied Btn+1, Midi note of copied Btn+2, Midi note of copied Btn+3....

In the example above this would be in Channel/Note format:-

First button pasted >1/13, second button pasted >1/14, third button pasted >1/15...

The pasted Midi Channel number is always the same as the copied button.

As an example, button 81 has Midi In/Play allocated to note 1/70

SOUND22 1/70 81a 00:01	SOUND24 82a 00:01	SOUND25 83a 00:02	SOUND26 84a 00:01	SOUND27 85a 00:02
------------------------------	----------------------	----------------------	----------------------	----------------------

If the Midi notes on buttons 82..88 are to be assigned notes 1/71..1/77, then the procedure is to copy button 81 to the clipboard, and to use Paste Special SetUp to Auto Fill the buttons 82..88 as shown below

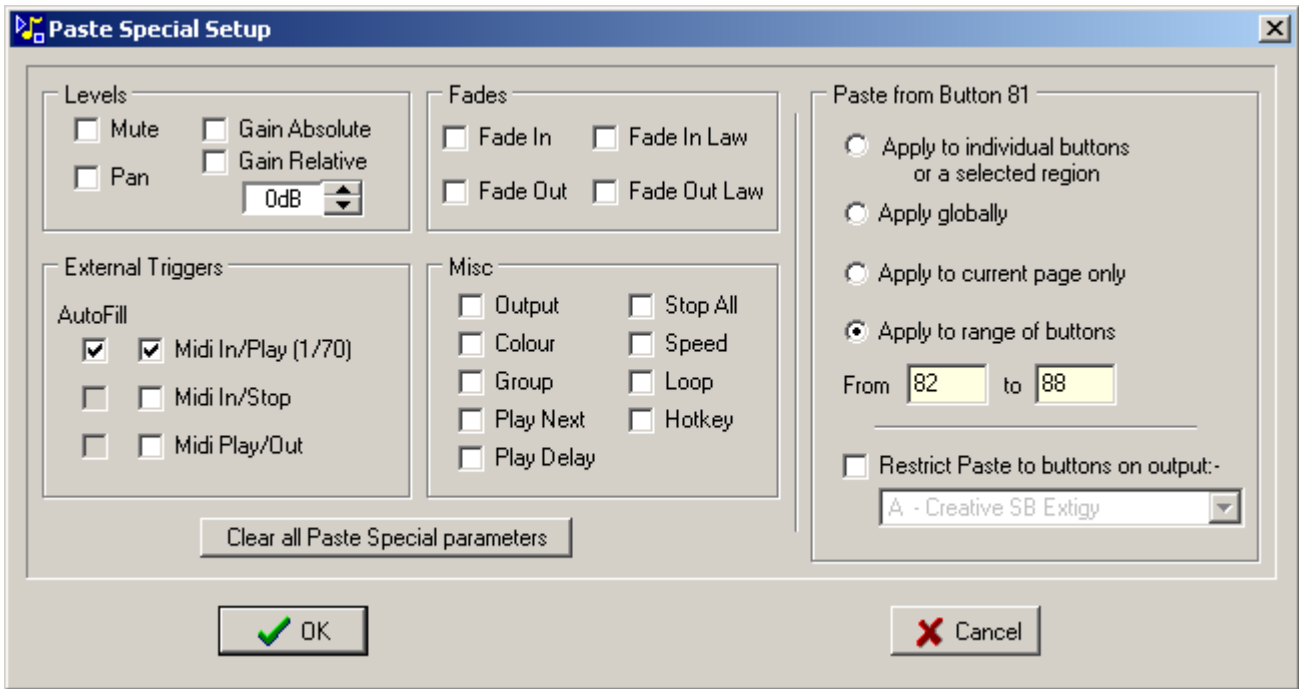

A prompt dialog appears confirming the changes

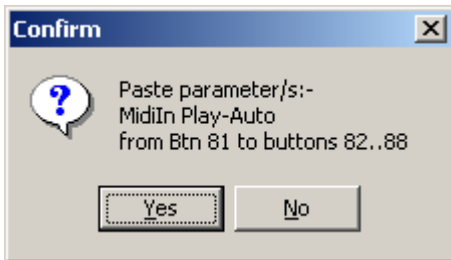

The result then becomes:-

SOUND22 170 81a 00:01	SOUND24 171 82a 00:01	SOUND25 172 83a 00:02	SOUND26 173 84a 00:01	SOUND27 174 85a 00:02
-----------------------------	-----------------------------	-----------------------------	-----------------------------	-----------------------------

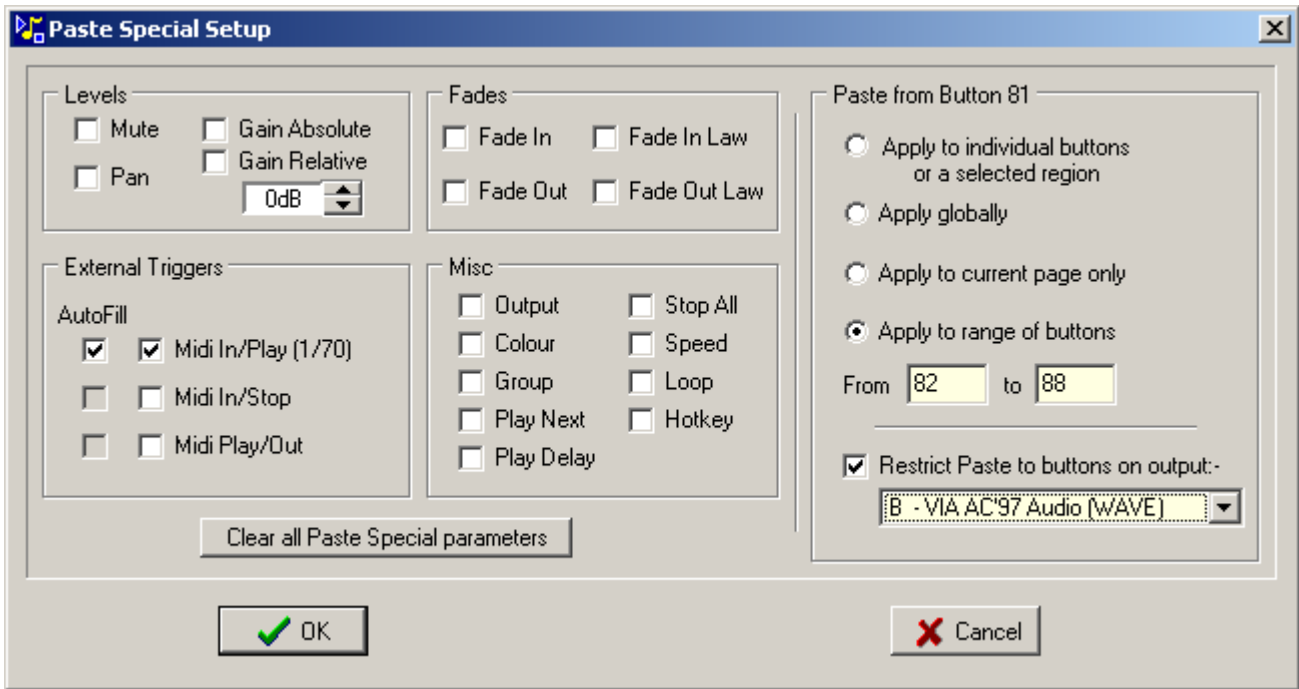

If the option to restrict the Paste Special action to buttons only on a specific output the prompt box will appear as below.

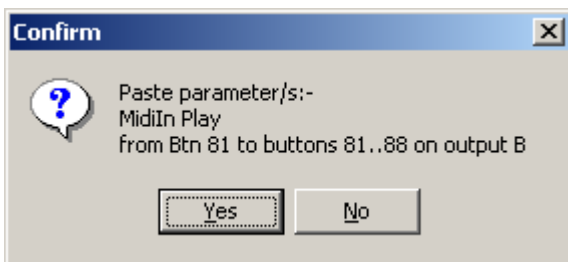

## Fill Buttons

This option provides a quick method of loading the same audio file into a range consecutive buttons, this may be required when setting up SpotOn so that all spare buttons are loaded with for example 1 second of silence.

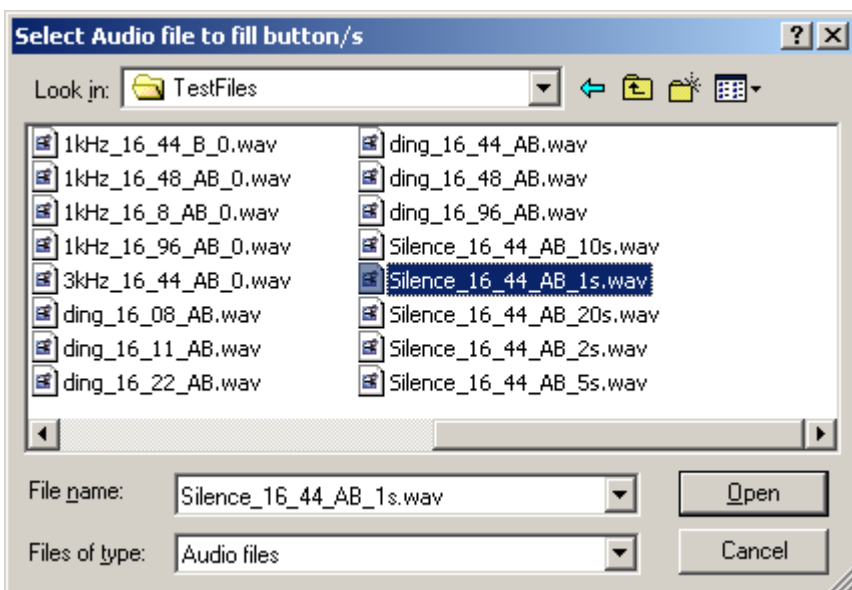

The first dialog box to be presented allows selection of the audio file followed by a further dialog defining of the range of buttons to be loaded

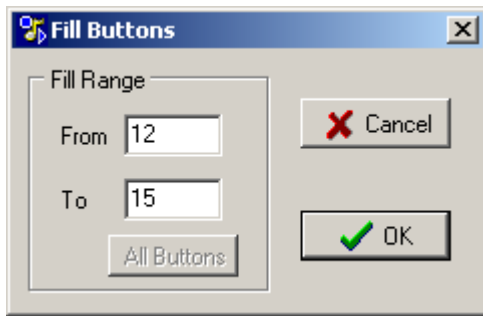

Finally a confirmation dialog box before the buttons are loaded.

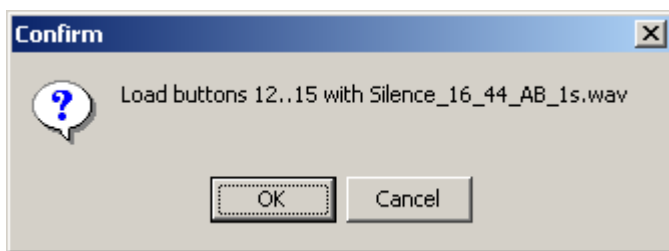

### Clear Buttons

To clear tracks from one or more buttons enter the first and last button numbers then click OK

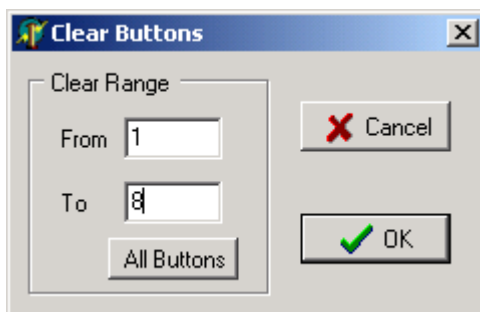

Click on "All buttons" to enter the full button range

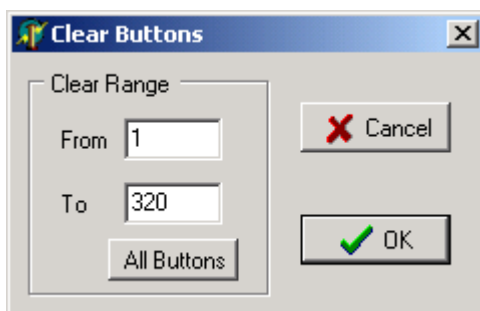

A confirmation dialog is shown before the buttons are cleared.

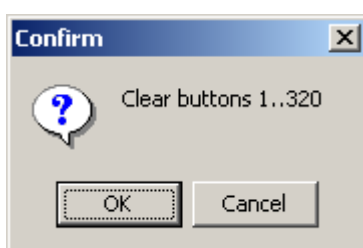

# Search Menu

The Search menu will display a popup window similar to that shown below containing the 1000 most recent files loaded into SpotOn.

The names listed are the disk filenames or display names if they were altered when loaded into SpotOn. They can be searched by typing directly into the Search Text edit panel, here 'sun' has been entered and the file 'sunshine' has been moved to the top of the list.

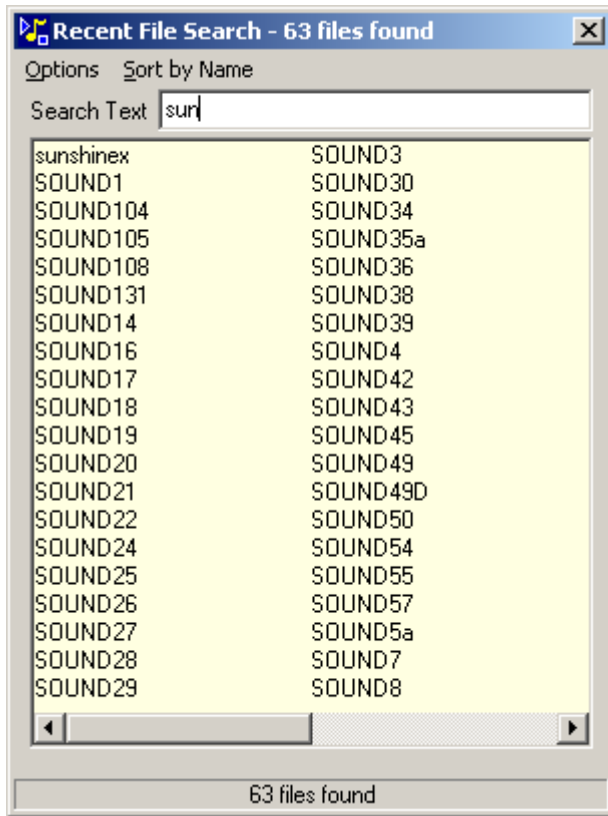

Once the required file has been located it can be selected and then dragged and dropped on to the appropriate main window button. Drag and Alt+Drop will automatically Top/tail track before it is loaded onto the button

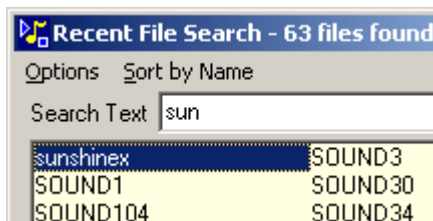

The actual location of the audio file is show in the search window status bar.



## Sorting Search List

By default the list of tracknames will be sorted in ascending alphanumeric order.

The 'Sort by' menu allows the list to be sorted in alphanumeric order or with the most recently loaded tracknames at the beginning of the list.

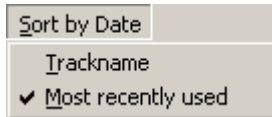
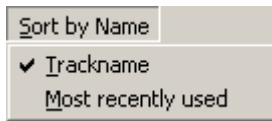

## Remote Files

Tracks sourced from remote file locations are included in the list only if the [Try Remote Files](#) option is selected, in that case any remote files will be shown in red text.

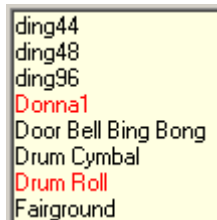

## WAV files containing Copyright or Comment fields

WAV files can contain embedded text fields detailing copyright, artist, creation date etc., the Options menu allows files having entries in either the Copyright or Comments fields to be highlighted in the search list.

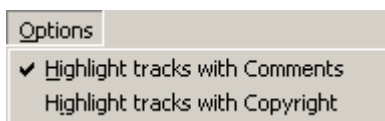

Checking the Highlight Comments option displays the file name in blue if it has an associated comment field.

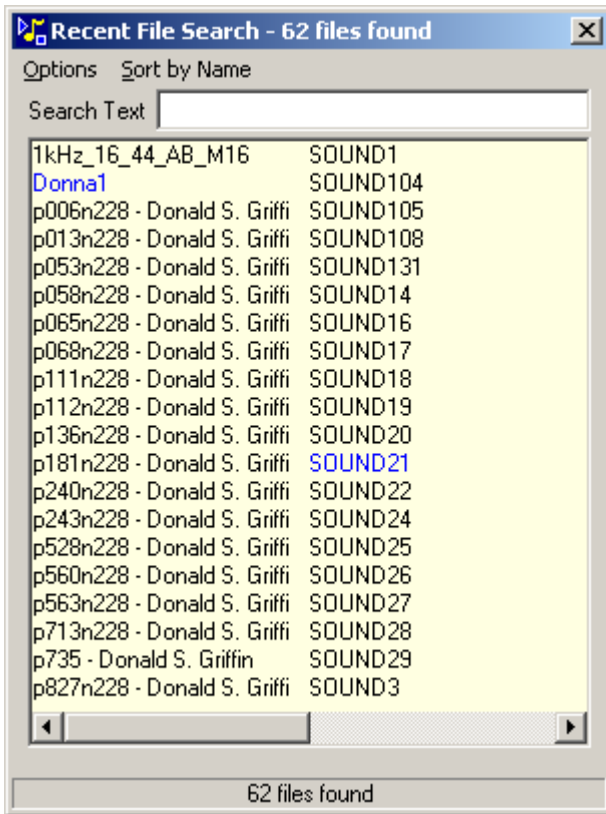

Selecting the file will show the comments in the upper status bar

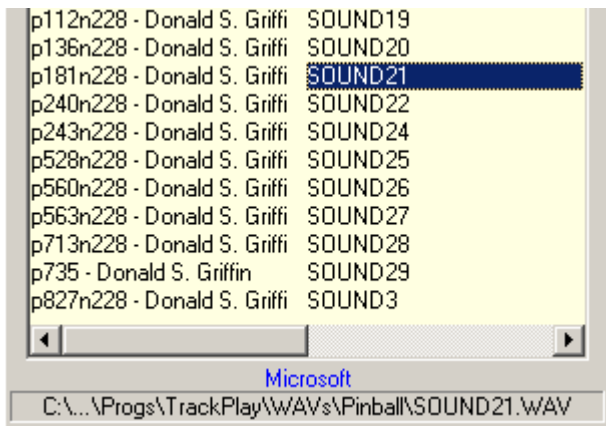

### Preview Track

The tracks can be previewed individually by double-clicking files in the results list. So for example the entries for 'Sound21' and 'Sound22' can be compared by double-clicking the names, right-clicking will stop the track as will closing the Search window.

The previewed audio will be played on the output that was selected as being the 'Preview Output' via Global|[Preview Output Assignment](#).

# Global Menu

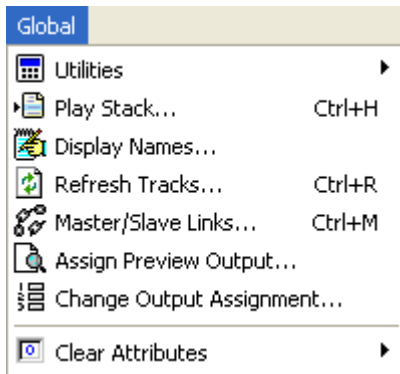

<a href="#">Utilities</a>	Assorted utilities giving information about current session
<a href="#">Play Stack (Ctrl+H)</a>	Simple track player utility
<a href="#">Display Names</a>	Edit display names and change track/button allocation
<a href="#">Refresh Tracks</a>	Update tracks that have been modified since being loaded
<a href="#">Master/Slave Links</a>	Setup links between Master buttons and Slave buttons
<a href="#">Assign Preview Output</a>	Sets output to be used when previewing tracks
<a href="#">Change Output</a>	Change audio output device for some or all buttons
<a href="#">Clear Attributes</a>	Clear selected attributes

## Utilities

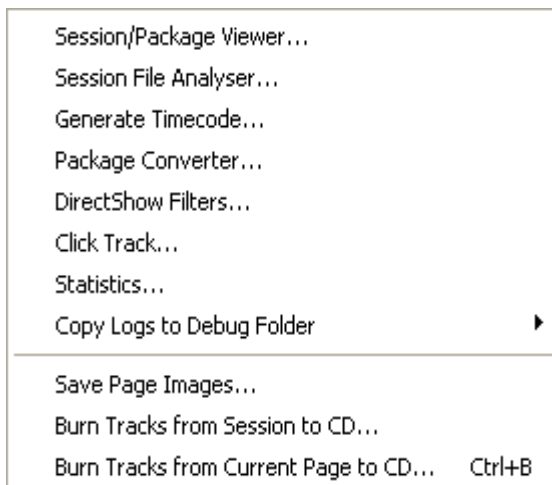

<a href="#">Session/Package Viewer</a>	View contents of SpotOn Session and Package data files
<a href="#">Extract Tracks from CD</a>	Extract tracks from CD and save to disc as WAV files
<a href="#">Session File Analyser</a>	Analyse usage of audio files in sessions
<a href="#">Generate Timecode</a>	Generate a timecode WAV file
<a href="#">Package Converter</a>	Convert Packages to be compatible with previous versions
<a href="#">DirectShow Filters</a>	Setup parameters for third party audio decoders
<a href="#">Click Track</a>	Generates a click/count in track
<a href="#">Statistics</a>	View audio file size and source folders
<a href="#">Copy Logs to Debug Folder</a>	Save a set of SpotOn files for debugging
<a href="#">Save Page Images</a>	Save images of the active pages to disc
<a href="#">Burn Tracks from Session to CD</a>	Burn tracks from the whole session to CD using
<a href="#">Burn Tracks from Current Page to CD</a>	Burn a selection of tracks to CD using CDBurnerXP

## Utilities-Session/Package Viewer

Session/Package viewer allows the contents of either a SpotOn session or package to be examined, it will list the button number output device and track title. The information can be selected and pasted to the clipboard for use outside of SpotOn

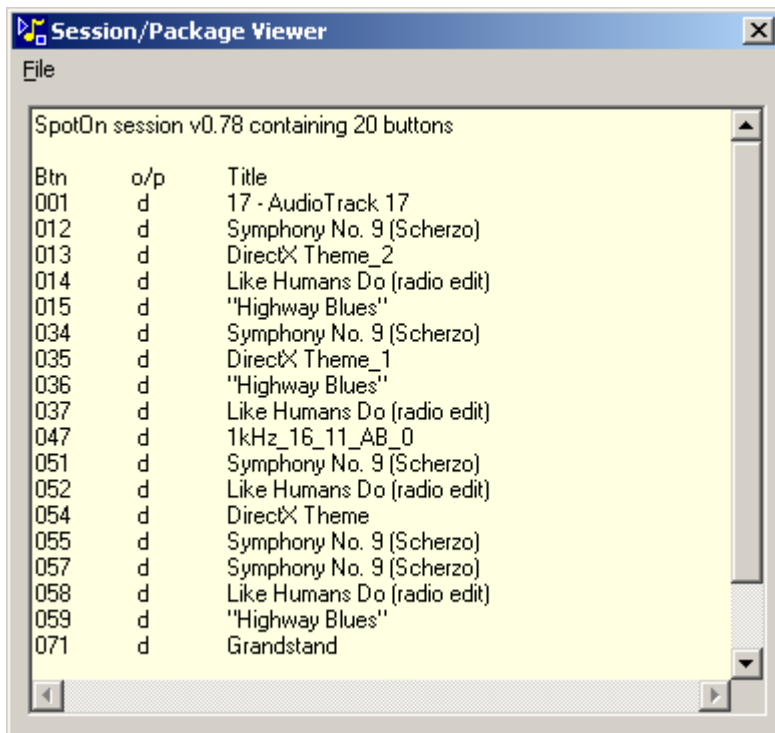

## Utilities - Session File Analyser

Session File Analyser is an application that runs external to SpotOn and is described on the [Session Analyser](#) page.

## Utilities - Generate Timecode

Occasionally it may be necessary to link the audio on a button with SMPTE timecode, this utility can create a WAV version of SMPTE timecode which when loaded onto a button can be played alongside the main audio with a Master/Slave link.

The first dialog box allows entry of the start timecode and the duration of the timecode track, in the example below timecode in the range 10:00:00:0 to 10:10:00:00 will be generated.

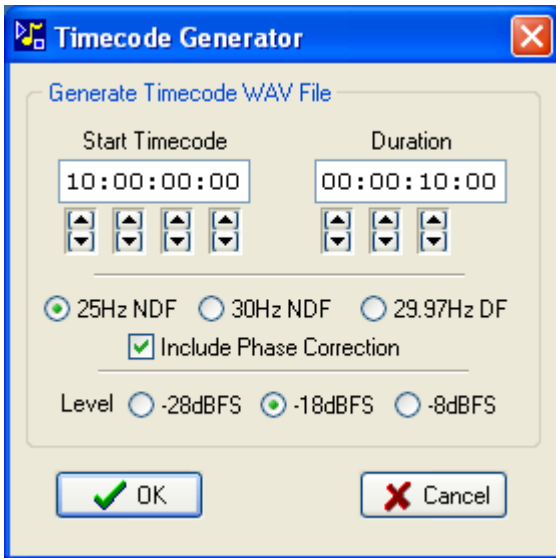

Options are available to set the timecode frame rate and signal level, -28dBFS equates to -10dBm.

The Include Phase Correction option allows a flag to be set in the timecode waveform to ensure the absolute phase of the sync word is maintained, most decoders can accommodate either setting.

Next the filename and location of the resultant timecode file is set.

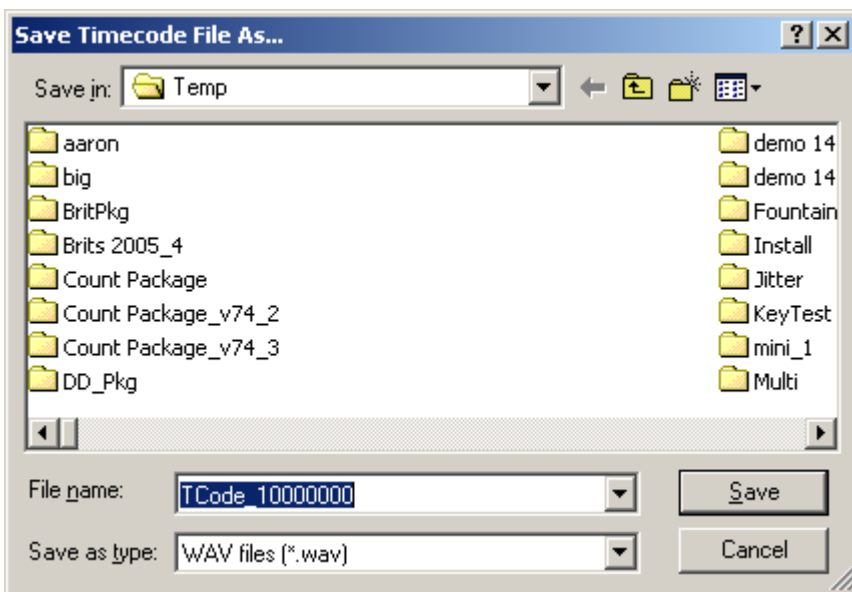

Finally a Wait window is displayed showing the timecode generation process, the cancel button will abort the operation.

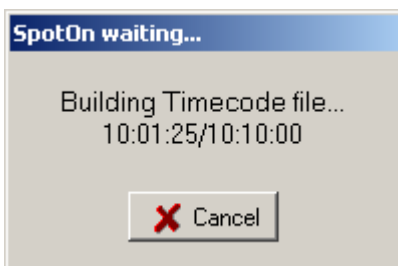

## Utilities - Package Converter

[Package Converter](#) is an external standalone application that will convert SpotOn Packages from one version to another, this is used to convert packages built with more recent versions of SpotOn to run on older installations.

## Utilities - DirectShow Filters

Compressed audio files have to be decoded into uncompressed PCM WAV format before SpotOn can play the file, some of the DirectShow filters that perform the decompression have parameters that affect their output, the default settings are shown on the [Decoders](#) page

## Utilities - Click Track

A click track can be used as a timing reference or count in for musicians, SpotOn can generate a wide range of click track formats.

The parameters are set in the dialog shown below, the taps and beats can be previewed via the [Preview output](#)

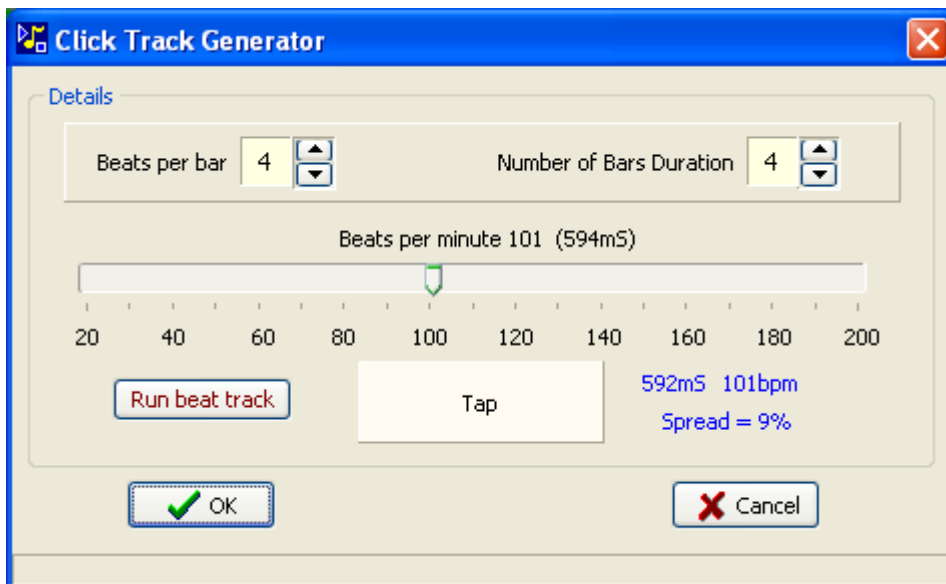

Clicking on OK will start building the file.

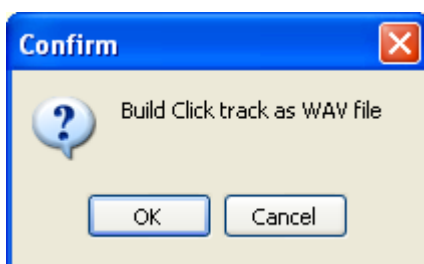

The file will be saved as a single channel 16 bit 48kHz wav file.

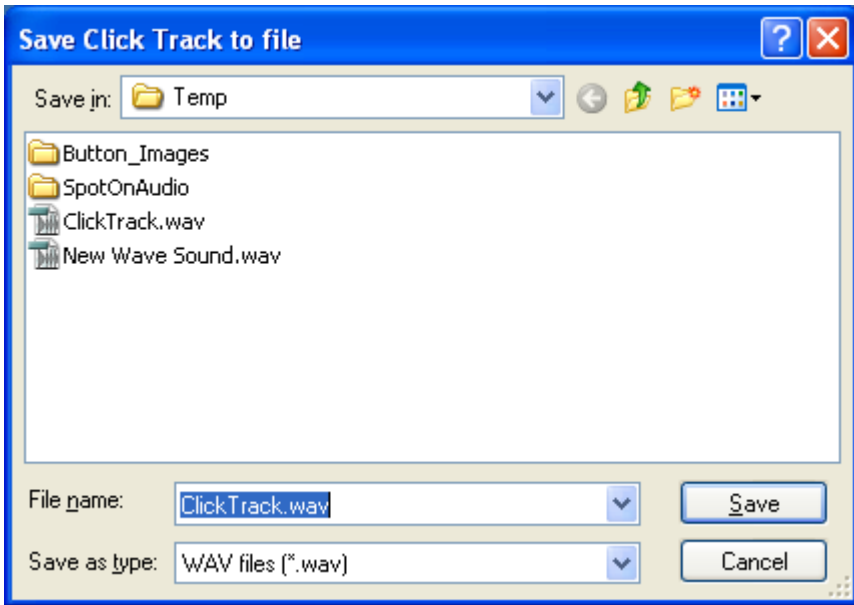

If the track is to be used immediately it can be loaded onto the next free button on SpotOn

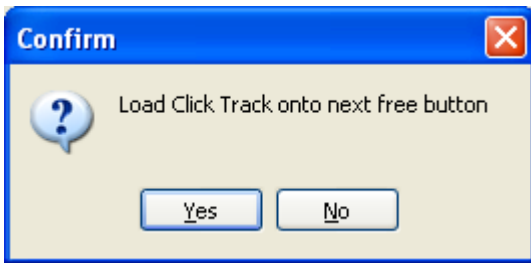

### Utilities - Statistics

Statistics show results of analysing the current session data, and is presented in two graphs

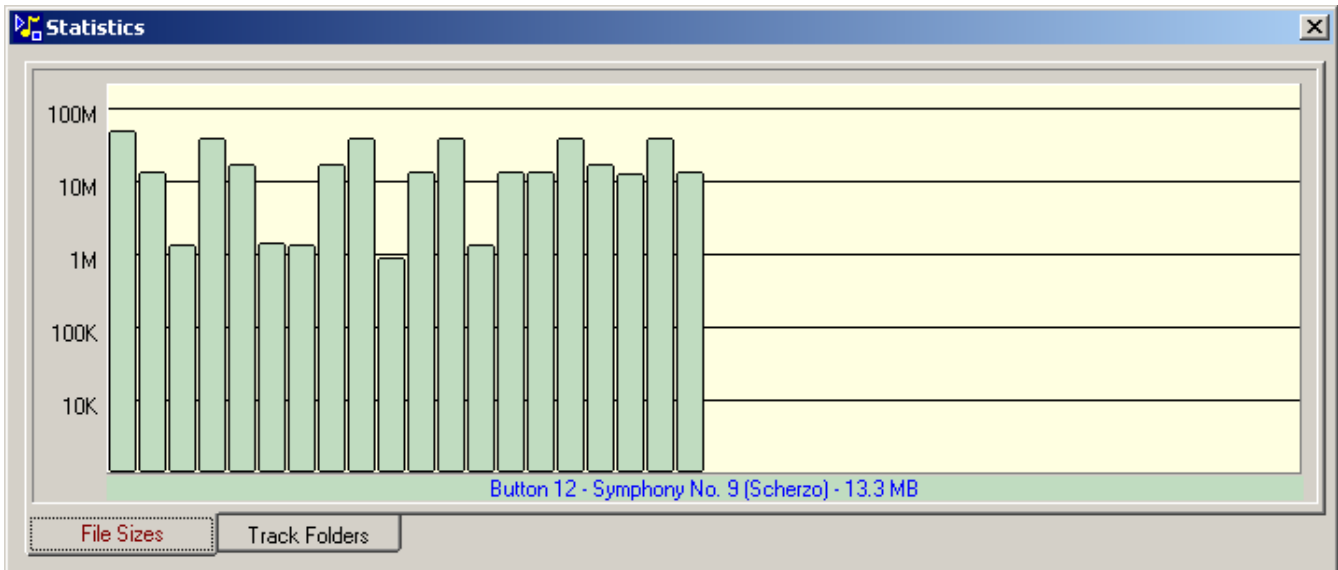

File Sizes displays a plot of file size for each button loaded, so that very large files can be identified.

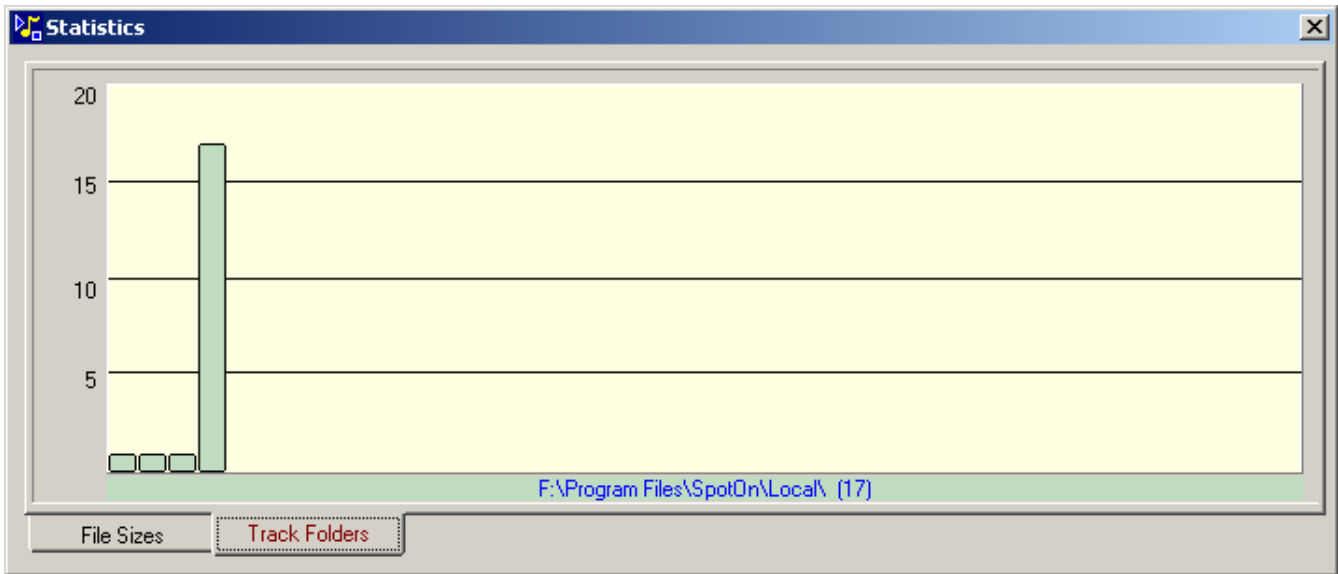

Track Folders displays the 'fragmentation' of the session, meaning how many different folders are used to store the audio files. In the above example the 20 files are spread across 4 folders, with 3 folders each containing one file and another holding the remaining 17.

When files are loaded from a networked or removable disc they are copied to the local disc into a 'Local Files' folder, as defined in the [File Folders](#) menu. This folder is highlighted in red in the Track Folders display to indicate that some files are held in the general 'Local Files' folder and not in a more relevant folder associated with a show/programme.

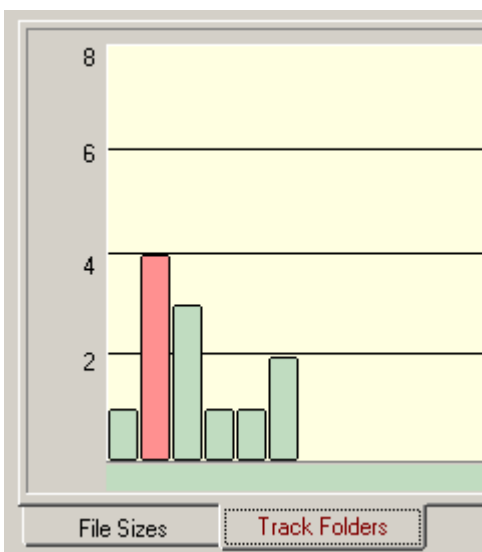

Right-clicking on any will show a popup menu

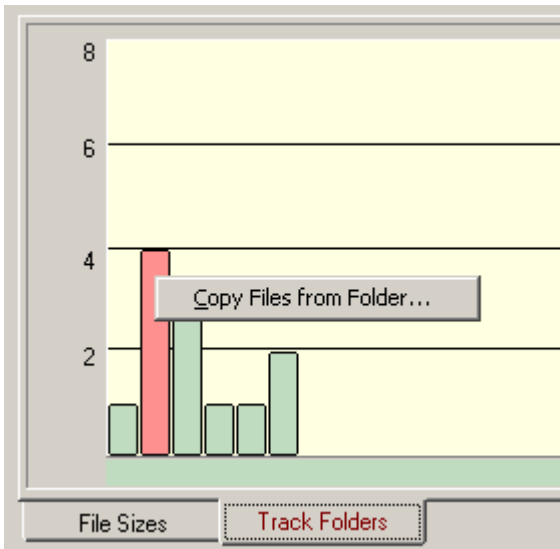

Clicking on the Copy Files menu item displays a dialog box confirming the the files are to be copied

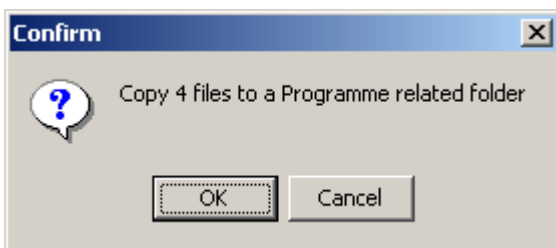

Next the new destination folder is selected

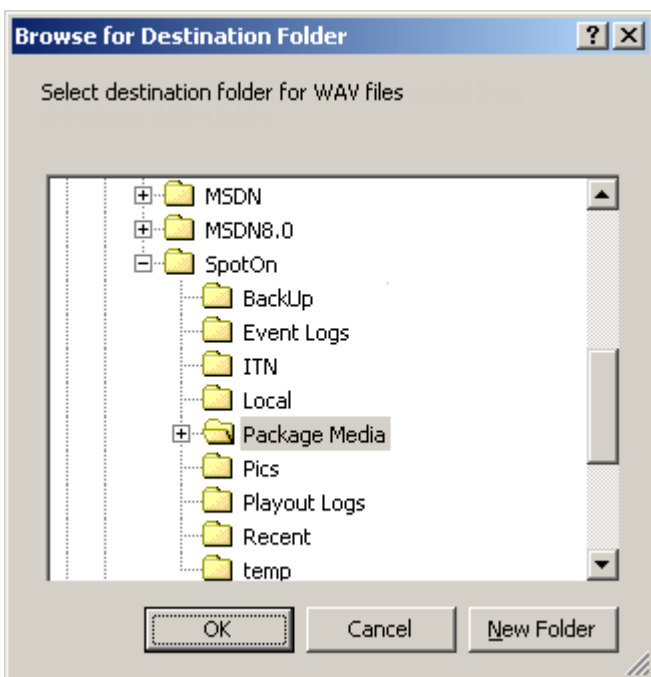

Finally a further confirmation before the files are copied.

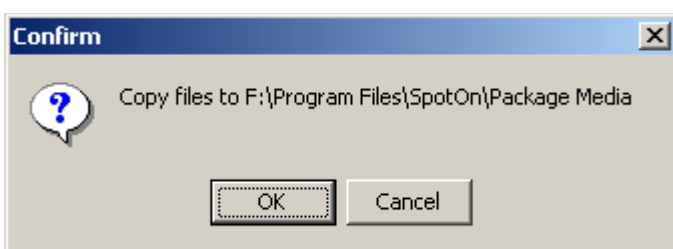

If a file of the same name already exists in the new folder then it will not be overwritten



### Utilities - Copy Logs to Debug Folder

A sub menu on this item allows the date range of log files to be specified, Payout, Event and Error logs are all included.

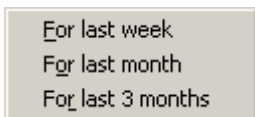

Selecting one of the above options will display a confirmation dialog warning that the contents of the \Debug folder will be deleted, this folder is only used by SpotOn for debug log files and no other files should be present.

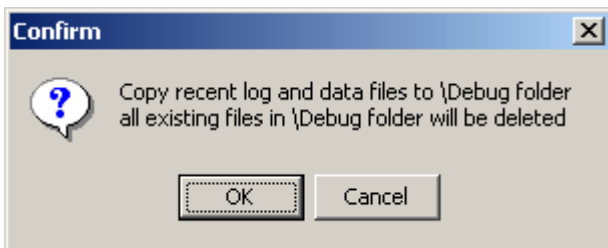

After the files have been copied a Debug.cab file is created and whilst this is being built a command line window will appear showing the compression progress

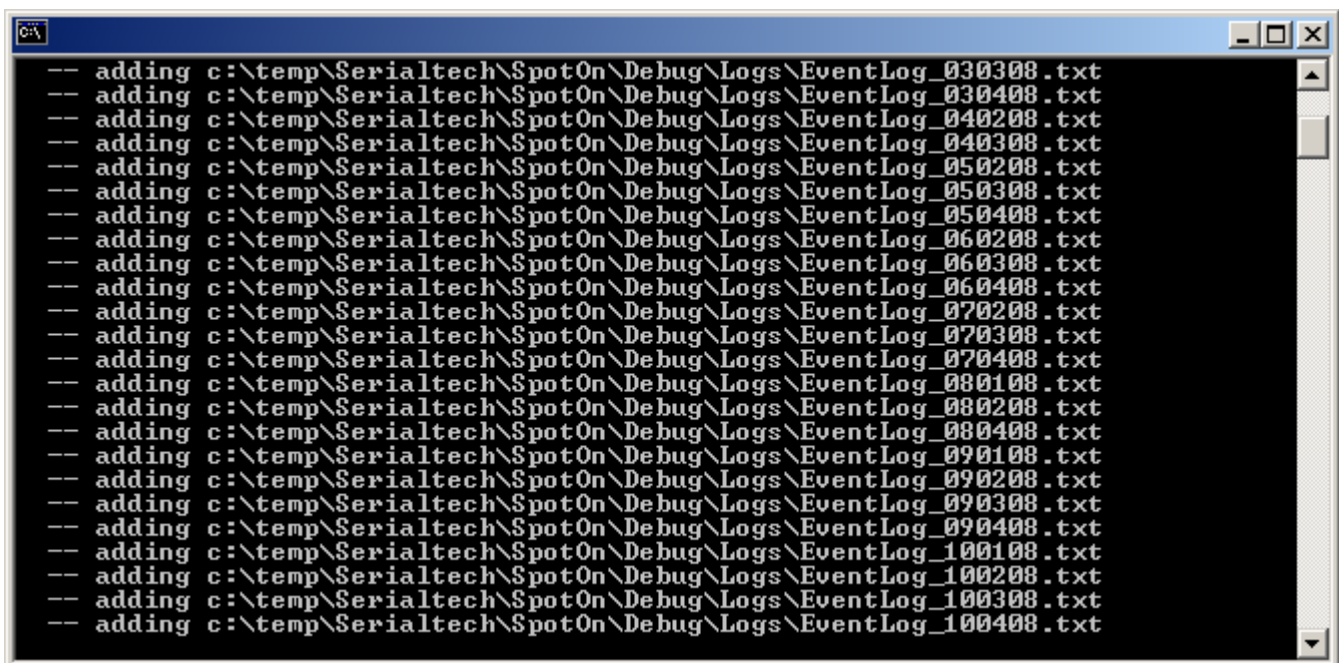

Next an option to transfer the debug files to a FTP server is offered, this uploads the files directly to a server so they can be analysed

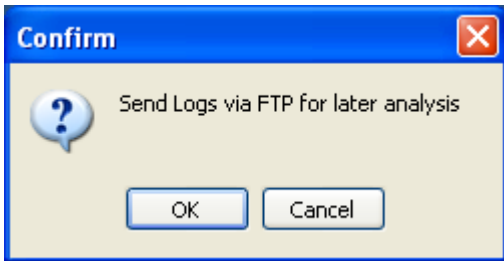

Selecting OK will open a FTP MiniClient window

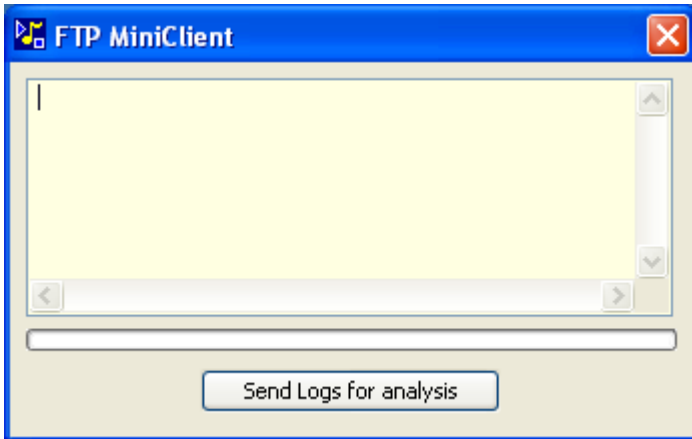

Clicking on Send Logs for analysis will start the file transfer

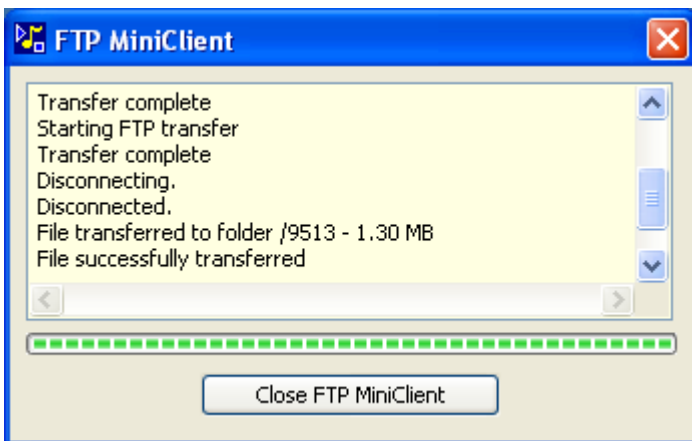

When completed close the window to continue

On completion of the copy/compression/FTP process there is a final option to display the contents of the \Debug folder

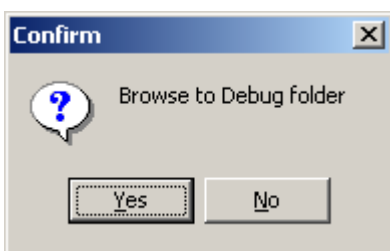

The "Debug\_Logs.cab" file can then be sent for analysis if required.

## Utilities - Save Page Images

To assist in passing information between SpotOn operators this menu option allows the SpotOn pages to be saved to file as either Windows bitmap or JPEG images.

The dialog box below allows the location of the image files to be set.

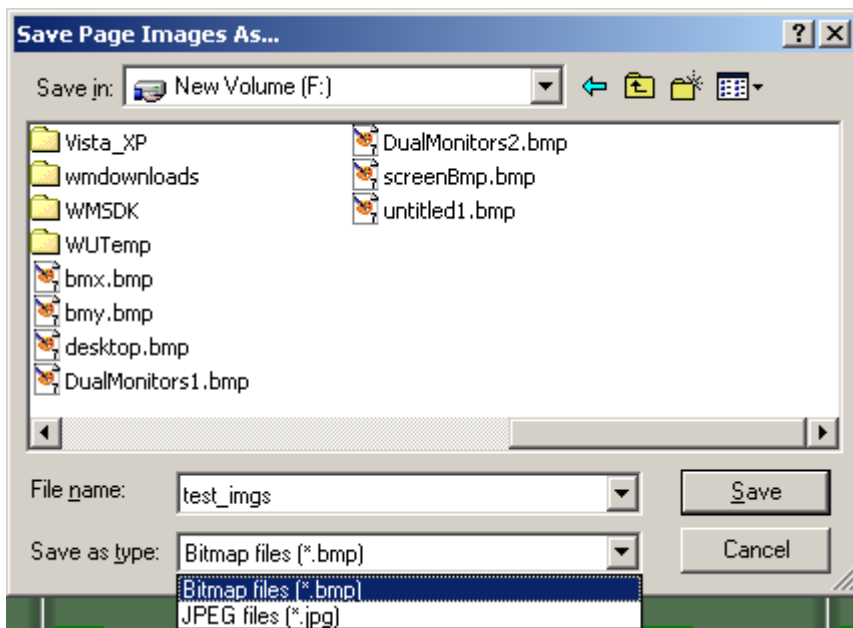

As the images are saved SpotOn will cycle through all available pages and then return to the originally displayed page.

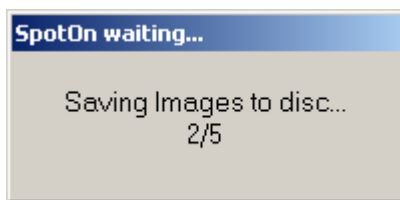

### Utilities - Burn Tracks to CD (Ctrl+B)

SpotOn is configured to use a third party CD burner utility "CDBurnerXP", the latest version of CDBurnerXP can be found at <http://www.cdburnerxp.se>

In order for SpotOn to access the utility the location of CDBurnerXP has to be assigned in the [SetUp menu](#).

By default all the tracks on the current page or session are selected for burning, alternatively a [source region](#) can be used with non-contiguous selections on a single page.

Next the type of file to burn onto the CD is selected to be either an Audio CD compatible with CD players or a Data CD containing the original \*.wav files for use with a computer.

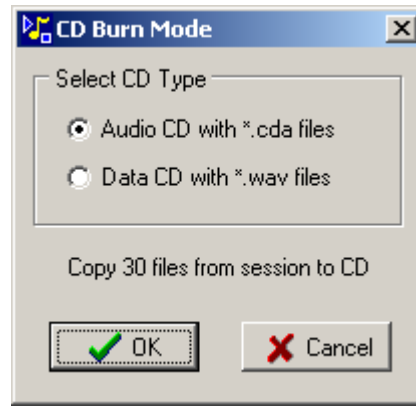
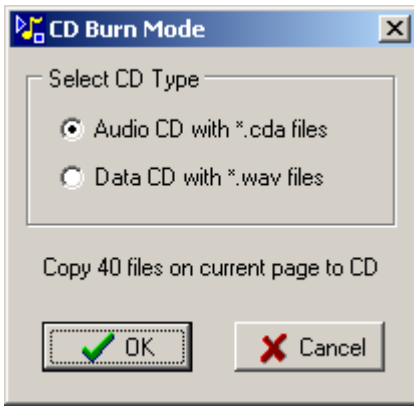

Note the files burned to CD are the original files without any modifications applied by SpotOn, i.e. gain, pan and trims adjustments are not copied across. However, in the case of MultiChannel files being saved to \*.cda tracks then the file will be mixed down to stereo.

The adjustments made by SpotOn to a track can be [rendered](#) to a copy of the track from the Trim window.

Clicking OK will open up the CDBurnerXP utility where the tracks to be burned can be edited or previewed

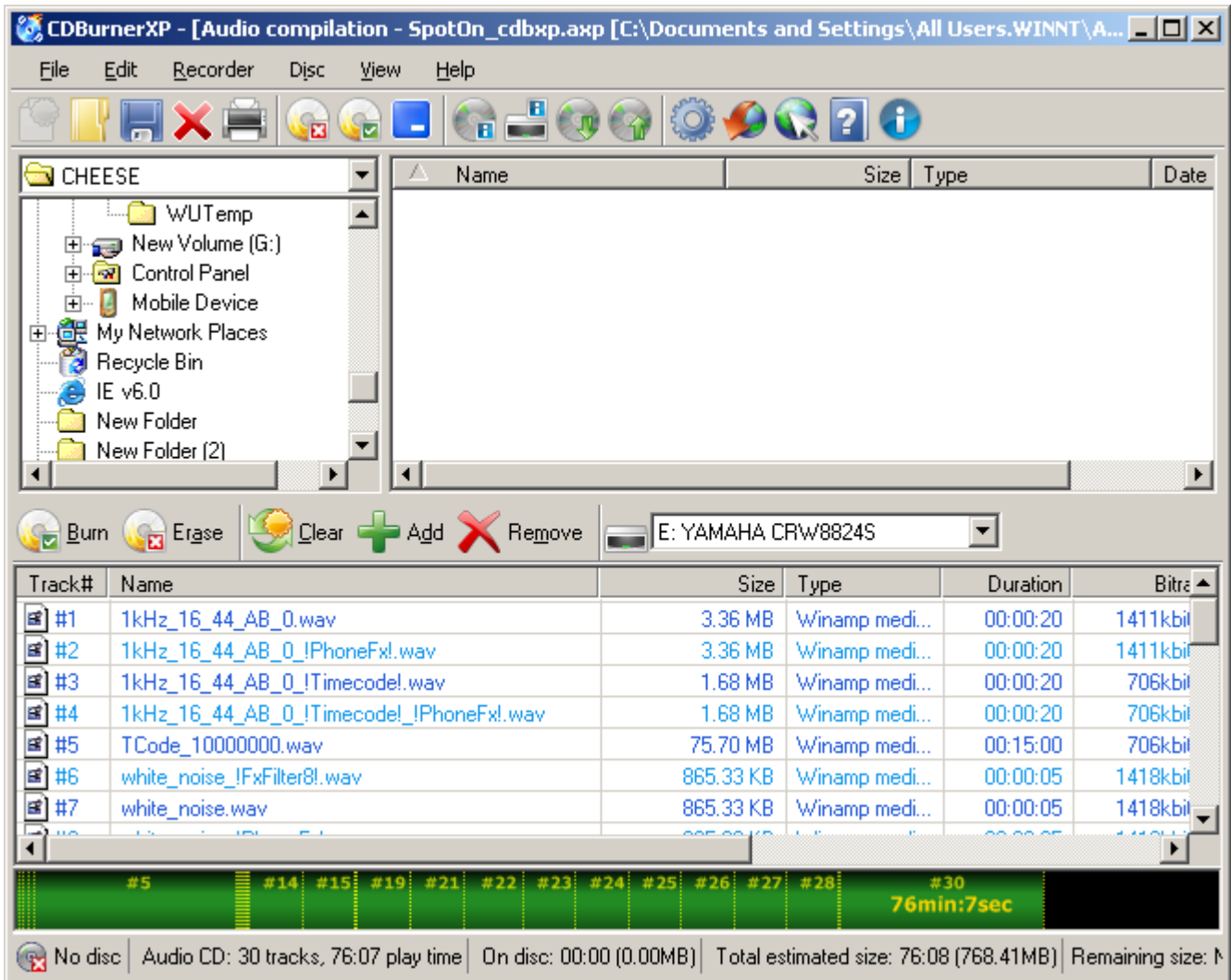

If no utility has been assigned or the file cannot be found the following message will be displayed.

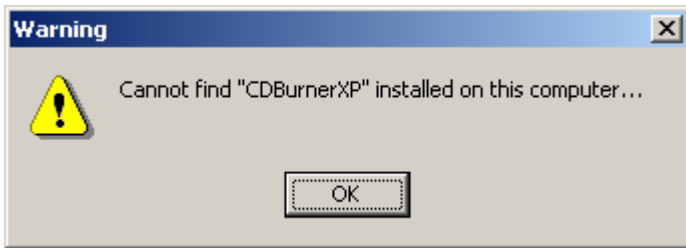

## Refresh Tracks (Ctrl+R)

If any tracks have been edited with an external WAV file edit application and then resaved, SpotOn will not know about the change until restarted or the button tracks are refreshed.

SpotOn could well be confused if audio files currently in use are modified externally, due to the information extracted from the audio file when originally loaded into SpotOn now being incorrect.

To avoid this situation clicking Refresh Tracks (Ctrl+R) will scan the disk files and compare the timestamps with those of the tracks currently loaded, files with more recent timestamps will be listed as shown below.

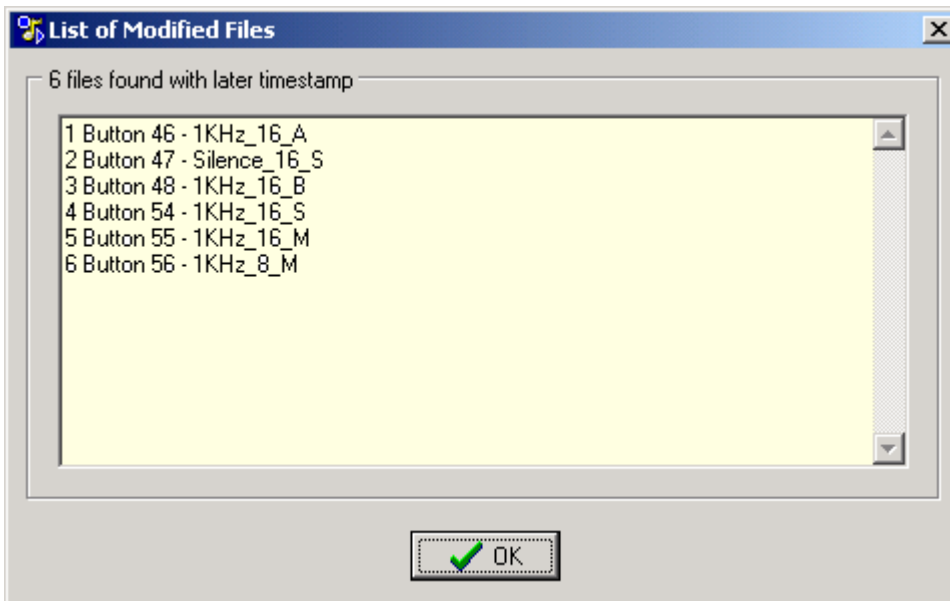

Following this dialog box is another to confirm that the updated tracks are to be loaded.

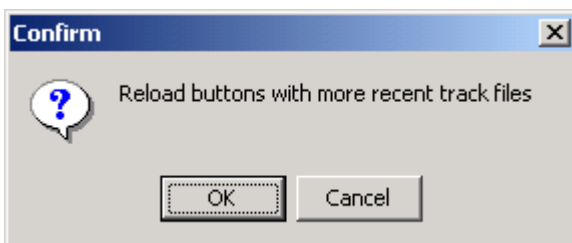

Playlist item selection and fade out times may be reset by this process, so the parameters of the buttons using these files listed must be checked and rehearsed before use.

When using the [Advanced Editing](#) option the tracks must be refreshed on completion of any editing operation

## Change Output Assignment

This option can globally change all buttons to use a specific audio output or only change those buttons already using a certain port.

The upper drop down box selects to audio output to be changed, and the lower box the output port that will be used instead.

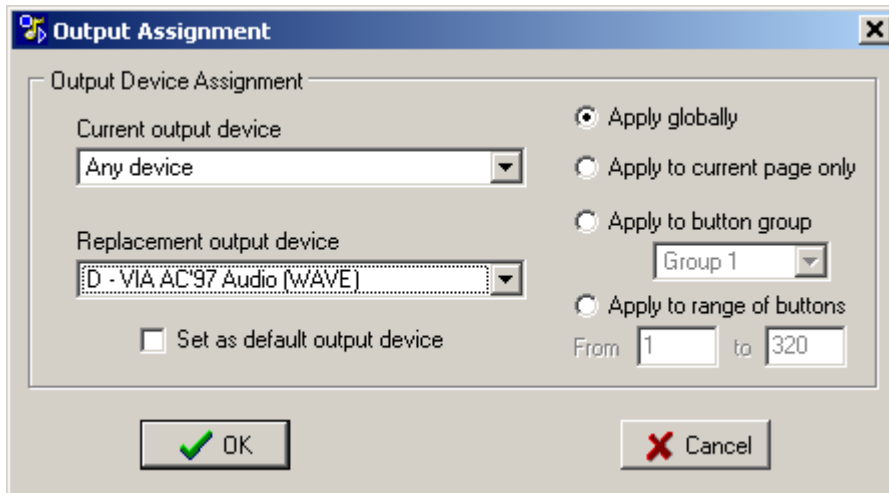

In the example above "Any device" is selected in the upper box and output "D" in the lower box, this will change all button to use output D. On the right hand side of the window the scope of the changes to output assignment can be set to either global, the current page, buttons on a specific group or a range of sequential buttons.

Clicking OK will show the confirmation dialog box.

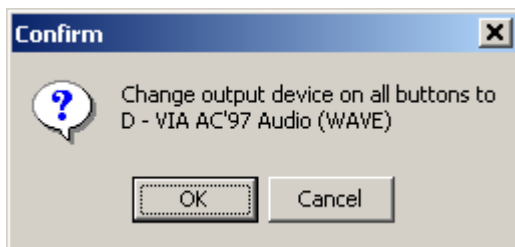

The second example below defines output device "E" in the upper box, in this case only those buttons that are currently using output E will be changed to output D.

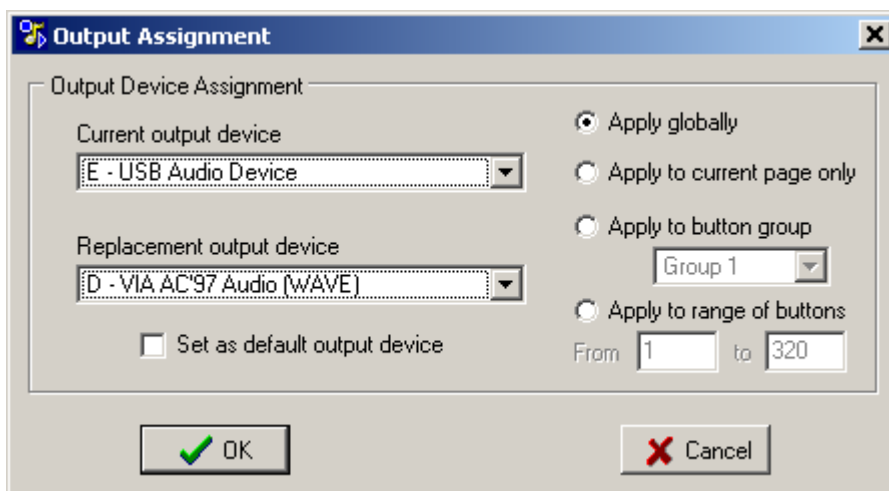

Checking the Set as Default option will cause any subsequently loaded track to be assigned to the output selected in the lower box.

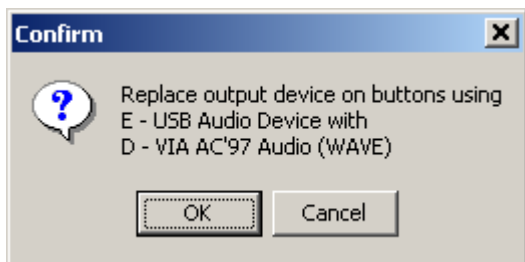

## Preview Output Assignment

When tracks are played they use their assigned output, however tracks can be previewed via an alternative output, this dialog box sets the Preview output.

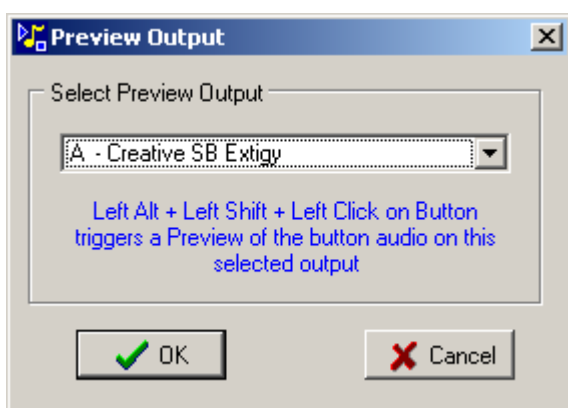

To enter the Preview mode from the main window press and hold left Shift and left Alt keyboard buttons, at this stage the DataRate panel will change colour to yellow and show "Pvw Mode".

Pvw Mode

Left-clicking on a button will now play that button on the Preview o/p only. The button preview can be stopped by holding down the left Shift and left Alt keyboard buttons and left or right clicking the button (depending on the mouse options selected).

The Preview playout is completely independent of the usual playout mode, so buttons can be played out of the normal outputs whilst being previewed, only one button can be previewed at any one time.

The button being previewed is shown with a crosshatch rectangle

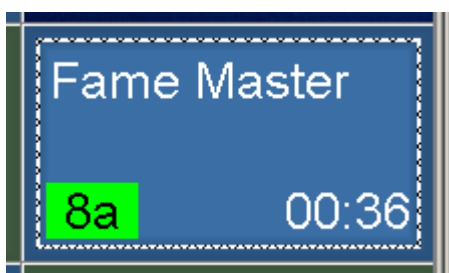

The time display will not count down during preview.

## Clear Attributes

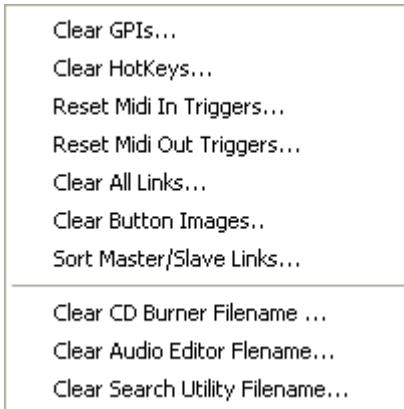

Clear GPIs

Clear Hotkeys

[Reset Midi In Triggers](#)

[Reset Midi Out Triggers](#)

Clear All Links

Clear Button Images

Sort Master/Slave Links

Clear CD Burner filename

Clear Audio editor filename

Clear Search Utility filename

Clear all GPI/button assignments

Clear all HotKeys assigned to buttons

Remove all Midi In triggers assigned to buttons

Remove all Midi Out triggers assigned to buttons

Clear all Master/Slave links

Deletes images images from all buttons

Sort Master/Slave links into "master button" order

Disable CD burner utility

Disable audio editor utility

Disable file search utility

## Reset All Midi In Triggers

Remove all the Midi In Note settings from all buttons



## Reset All Midi Out Triggers

Remove all the Midi Out Note settings from all buttons



# Display Names

Single button display names can be edited using the button menu [Display](#) option, if a large number need to be changed then the window below is more appropriate.

The left hand column show the button number, columns P, R, C show the page, row and column respectively.

The final two columns contain the display name and the original file name

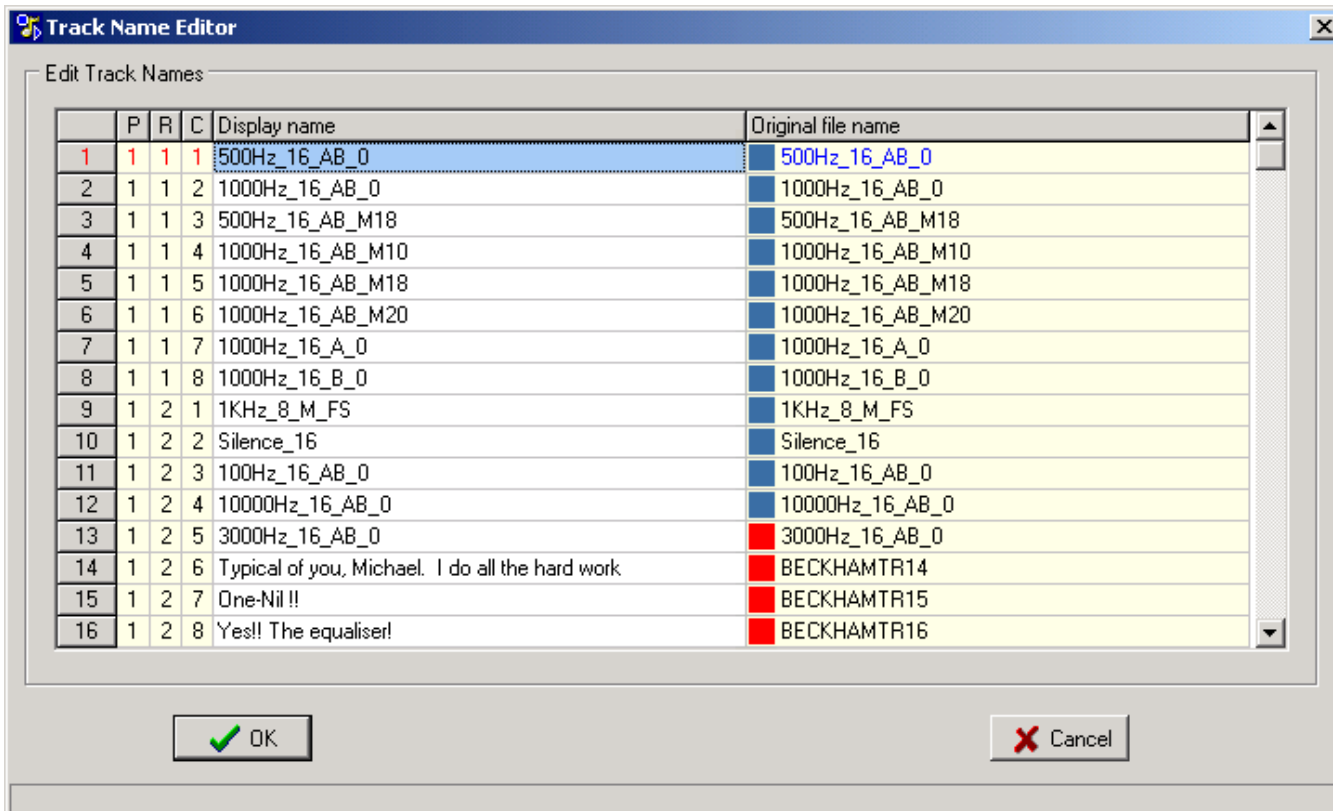

The display name can be edited by first selecting the cell and then double clicking to invoke the text editor

A close-up of the table from the Track Name Editor window. The cell containing "1000Hz\_16\_AB\_0" in the "Display name" column is selected, with a blue highlight and a text cursor.

	P	R	C	Display name
1	1	1	1	500Hz_16_AB_0
1	1	2	2	1000Hz_16_AB_0
1	1	3	3	500Hz_16_AB_M18
1	1	4	4	1000Hz_16_AB_M10

Another use of this window is the ability to reorder the tracks on the buttons

The entries in the right hand column can be dragged and dropped into new positions either singly or in blocks, button entries cannot be copied or cleared from this window.

To move a single track, simply click and hold down the left mouse button on the track in the filename column and drag the mouse within the column to the new location, the track will be inserted above the drop point.

To move multiple track the Windows shift+click selection method is used.

If in the example below the tracks 11..14 are to be cut and pasted between tracks 5 and 6, first select the tracks to be moved by clicking on track 11 in the filename column then shift+clicking on track 14 in the same column. The selected tracks will be shown in white on black text.

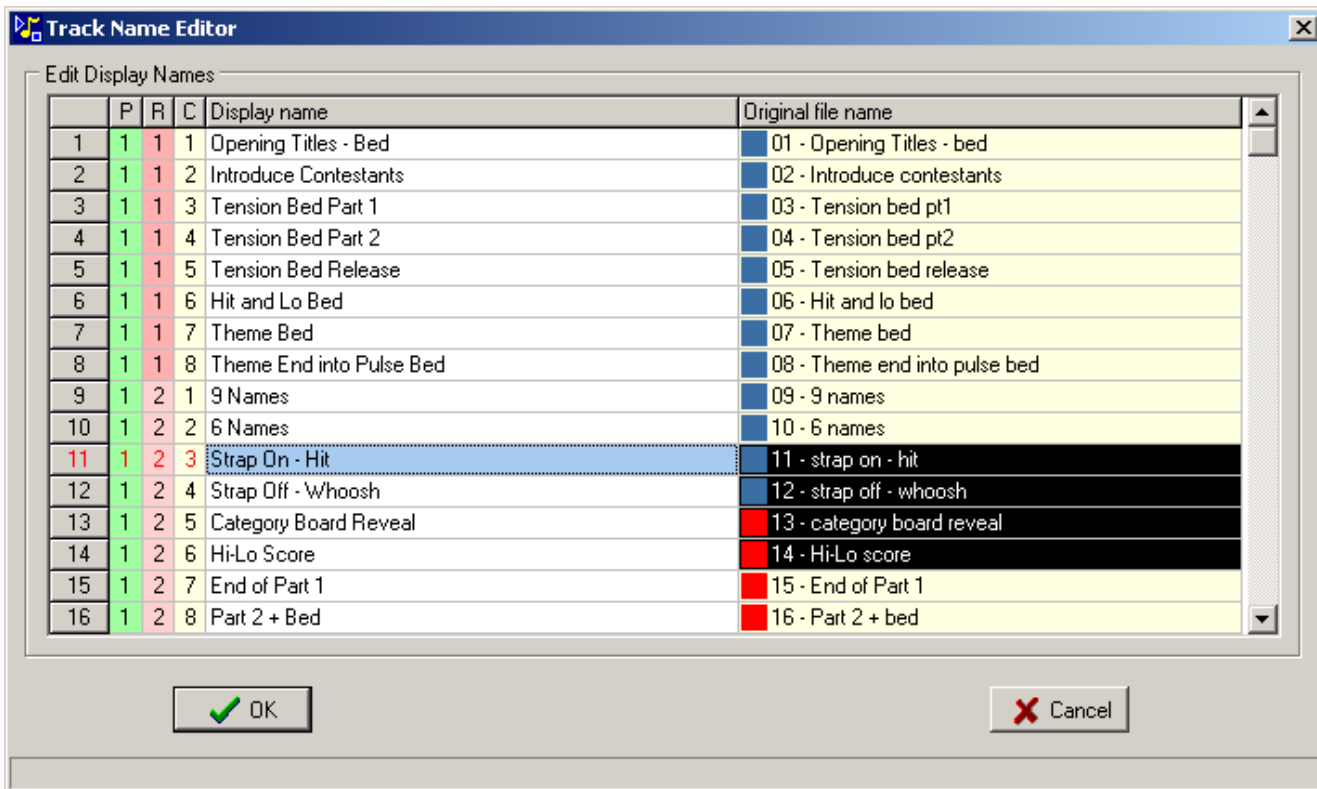

Now click and hold down the left mouse button anywhere in the selected area, then drag the mouse to the entry for track 6 in the same column.

Release the left mouse button and the selected tracks will be inserted above track 6 as shown below

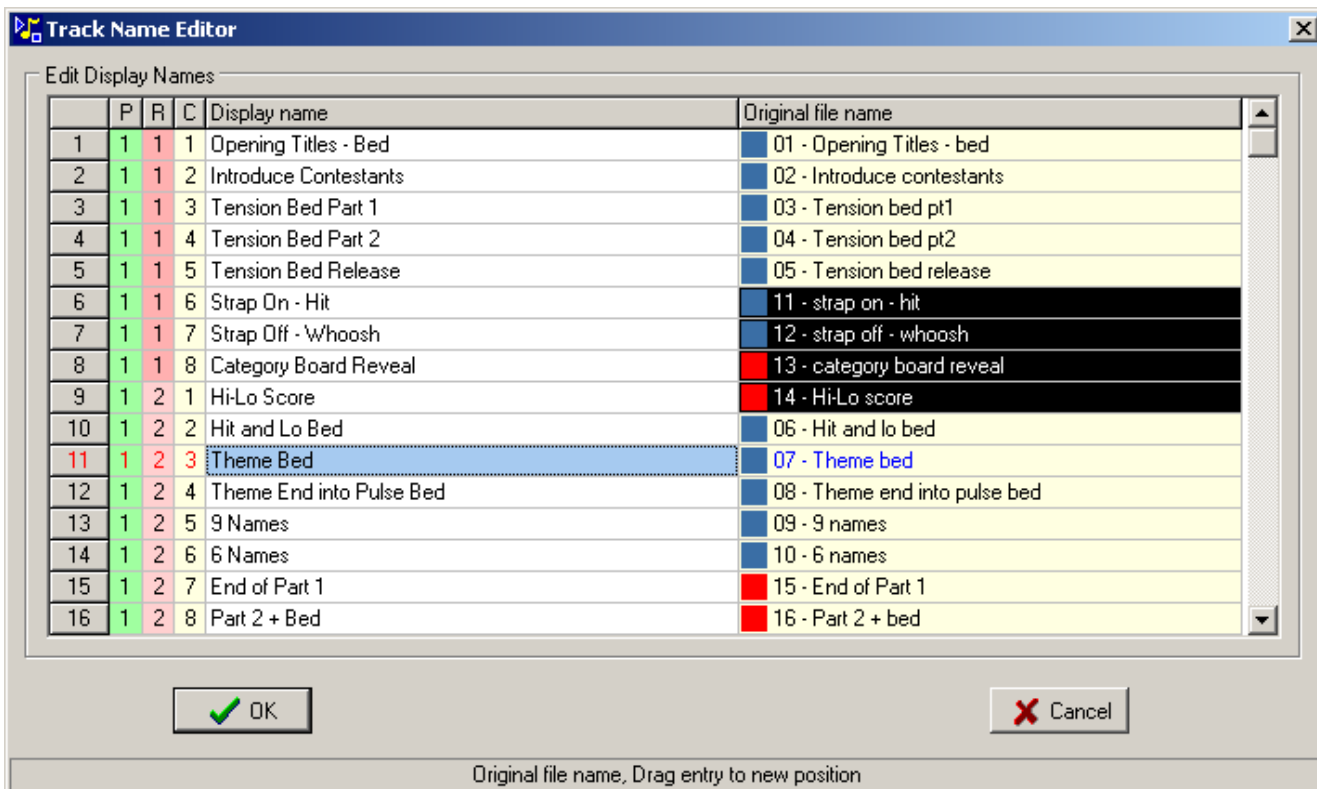

# Master/Slave Links

Buttons can be linked together so that one button (Master) can Play or Stop any number of other buttons (Slaves), alternatively buttons may be grouped so that playing any button in the group will stop all others in that group.

Special features such as Voice Over, Pause/UnPause and AutoPan can also be control via Master/Slave operation.

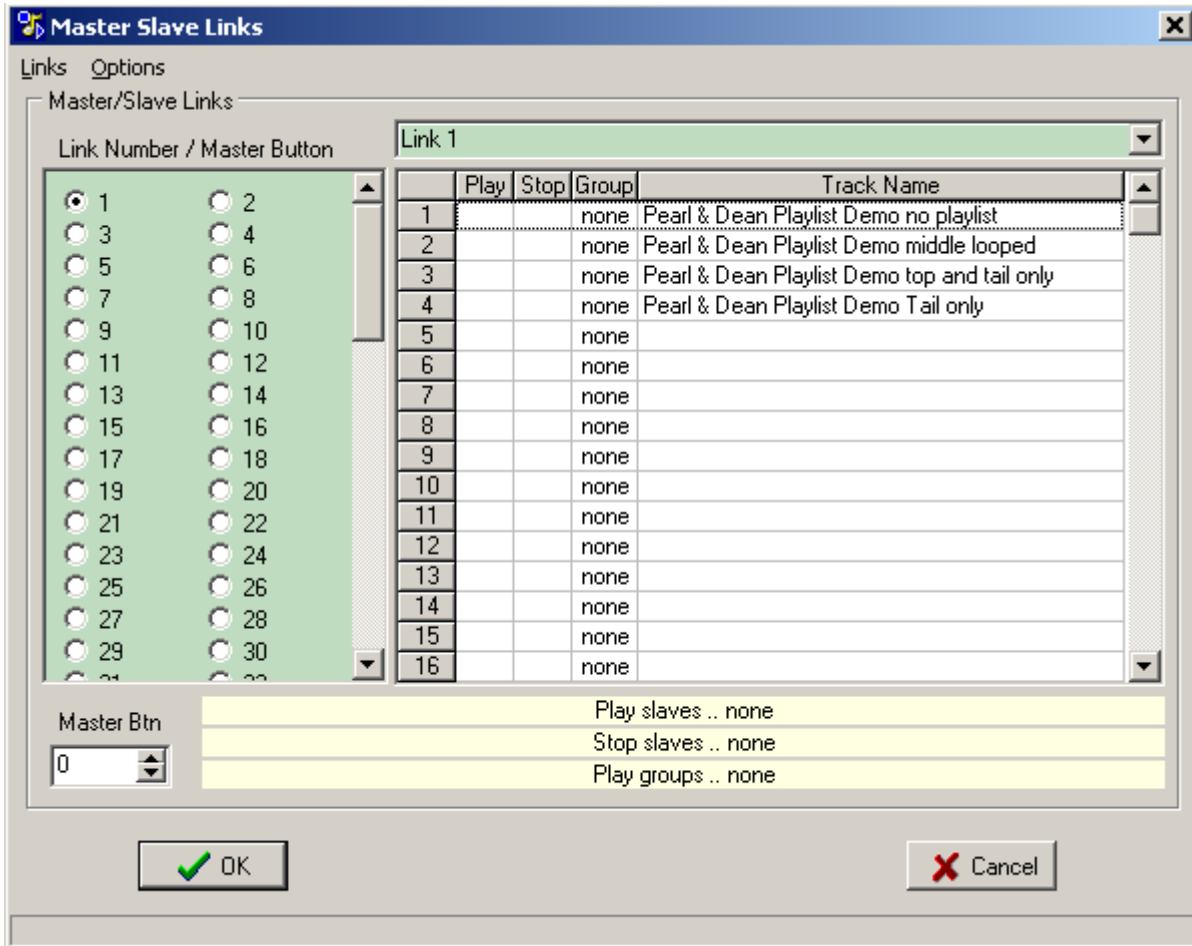

## Links

There are 100 Links that can be used, clicking on the left hand panel will select the appropriate link for editing, or alternatively selecting the link from the drop down list, the currently selected link is highlighted in blue text

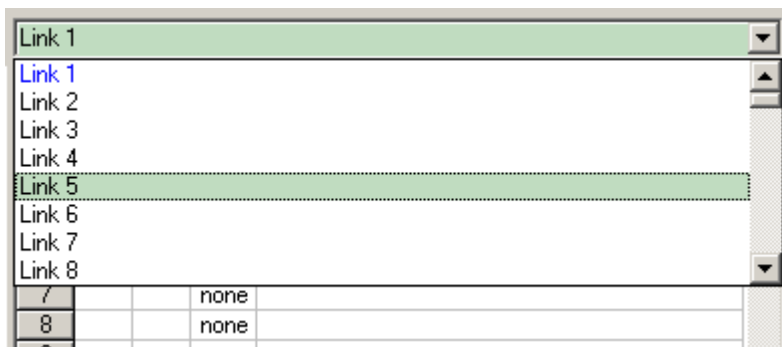

The Master button for a link can be typed in to the spin edit box or allocated by clicking the button number on the left hand side of the list, the selected Master button is highlighted in blue

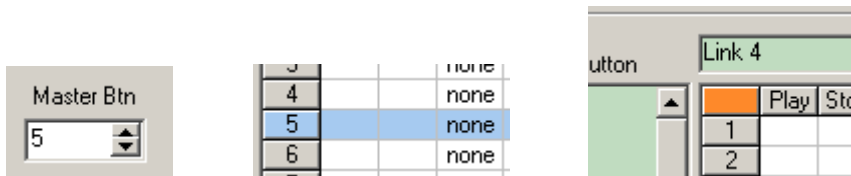

A link can be deleted by entering 0 as the Master Button or clicking the top left cell in the display grid - shown in orange above.

Play Slaves (those that will Play when the Master button is played) and Stop Slaves (those that will Stop when the Master is played) are allocated by clicking the appropriate cell in the list

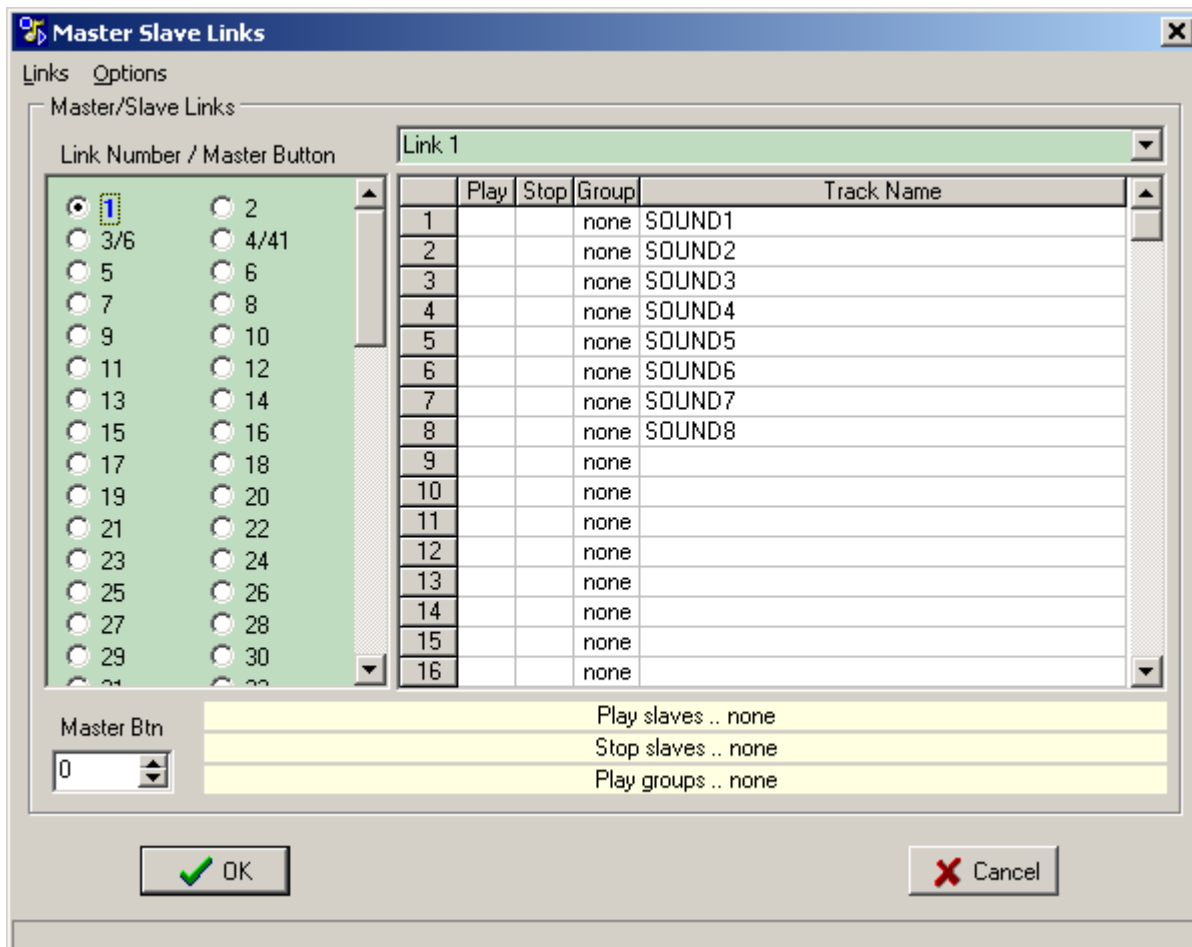

In the image above Link 1 is selected and is highlighted blue in the left hand panel, it has no master or slave buttons allocated.

Links 3 and 4 do have allocations and the master button is shown to the right of the link number i.e. 3/6 and 4/41

Selecting Link 3 shows the button allocations, buttons 1,2,3,4,5 will stop and button 7 will play when the master button 6 is played.

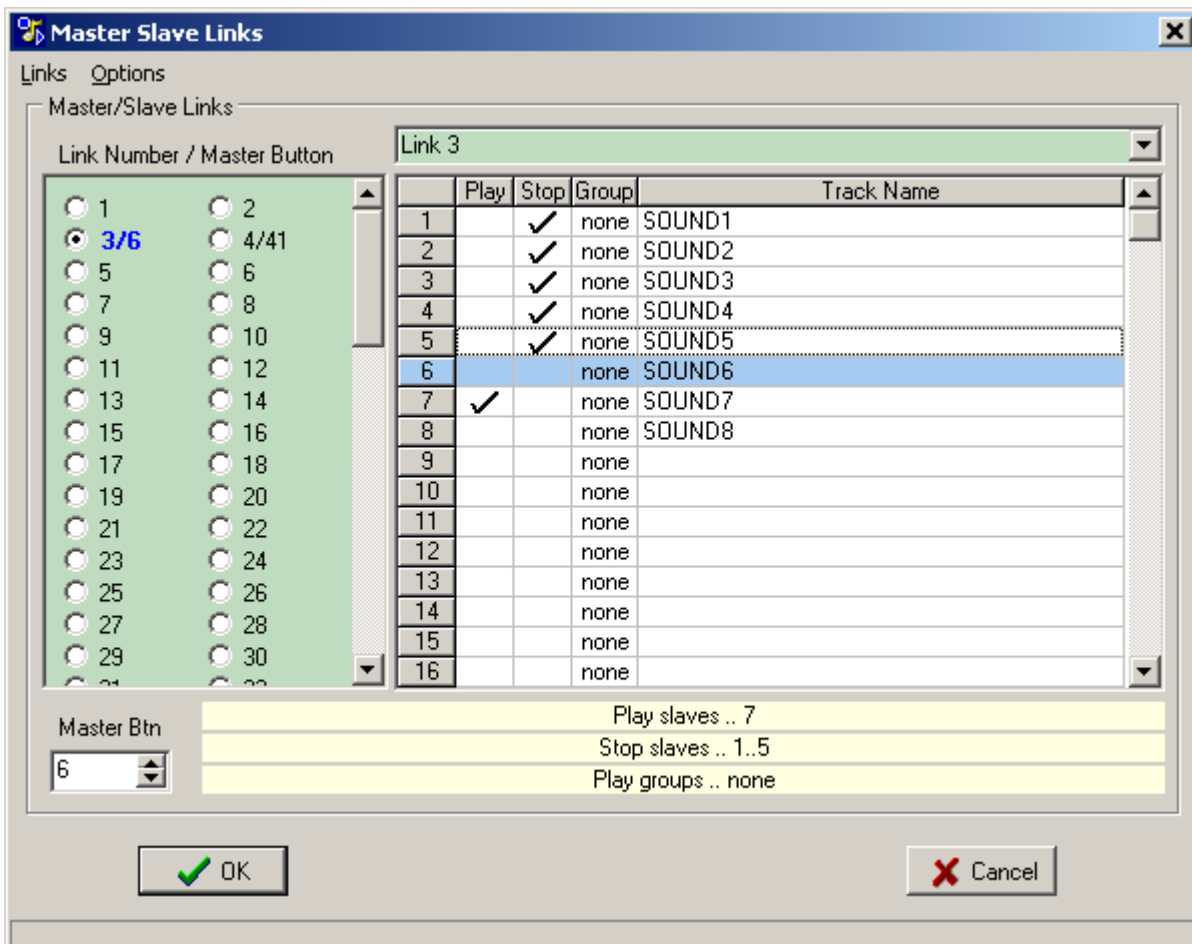

Similarly for link 4 buttons 39,40 will play and buttons 42,43,44,45,46 will stop when the master button 41 is played

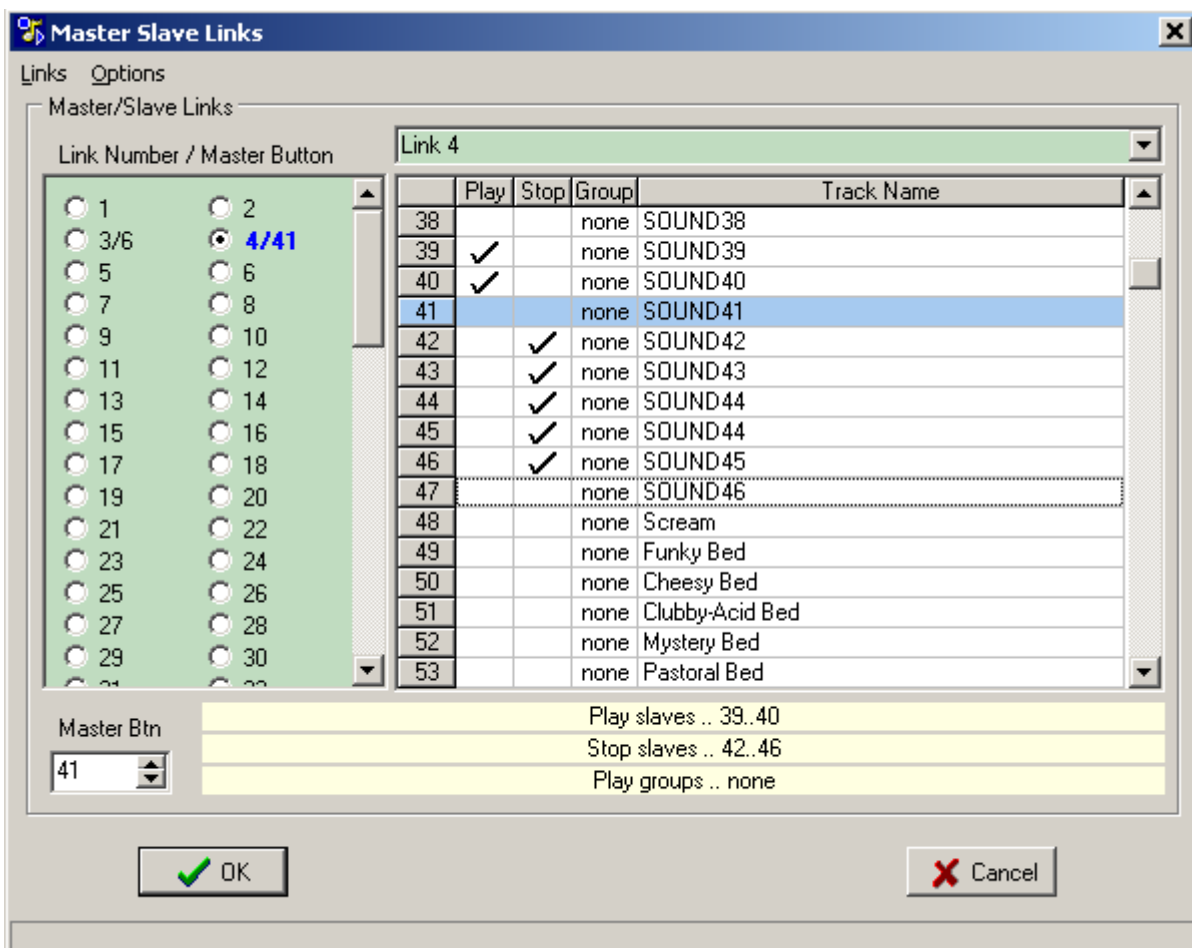

A summary of the allocated buttons is shown at the bottom of the button allocation list

The individual links can be named by typing into the drop down list selection

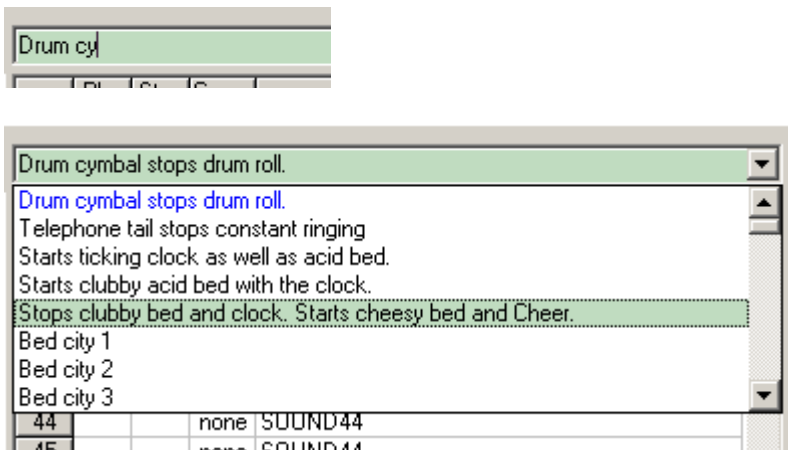

The links can be sorted into Master Button order using the Global|Sort Master/Slave Links option

If the Master/Slave links are currently disabled the message below appears at the bottom of the dialog box



The Links menu allows for the link names to be reset to their default of Link 1.. Link 99, and all Groups and Links to be cleared.

In addition the Links can be analysed and broken links displayed, a broken link is defined as one where the Master button is unused or all the Play and Stop slaves are pointing to unused buttons.

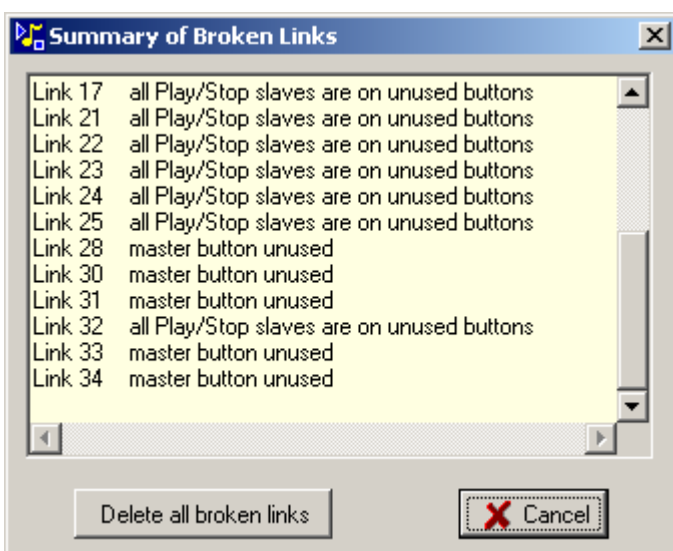

An option to delete all broken links is available

An additional menu is available by right-clicking the Play or Stop columns.

	Play	Stop	Group	Track Name
1			none	dinn 16 NR AR
2				
3				
4				
5				
6				
7			none	
8				

Clear All Groups

Clear All Play Slaves

Clear All Stop Slaves

Clear All Play and Stop Slaves

## Play Groups

As an alternative to using Links for collections of exclusive buttons Groups may be more appropriate.

There are 25 separate button groups and only one button assigned to a particular group can be playing at any one time, so playing a button will stop all other buttons in the group.

By default the buttons will not be assigned to any group and will show as "none" in the Group column

	Play	Stop	Group	Track Name
1			none	Pearl & Dean Playlist Demo no playlist
2			none	Pearl & Dean Playlist Demo middle looped
3			none	Pearl & Dean Playlist Demo top and tail only
4			none	Pearl & Dean Playlist Demo Tail only
5			none	
6			none	

Left clicking on the appropriate group cell will increment the group number and then roll back to none.

Right clicking the group cells displays a popup menu

✓ none	Group 10	Group 20
Group 1	Group 11	Group 21
Group 2	Group 12	Group 22
Group 3	Group 13	Group 23
Group 4	Group 14	Group 24+
Group 5	Group 15	Group 25!
Group 6	Group 16	Group A*
Group 7	Group 17	Group B*
Group 8	Group 18	Group C*
Group 9	Group 19	<b>Cancel</b>

Selecting an item will set the group value for that button, the screen shot below shows 5 buttons assigned to group 3.

The Play selection on button 7 is coloured red as it belongs to a Master/Slave link and is now invalid - Groups and Play Links cannot act on the same button and will be automatically deleted on exiting from the Links dialog.

	Play	Stop	Group	Track Name
1			none	SOUND1
2			3	SOUND2
3			3	SOUND3
4			none	SOUND4
5			3	SOUND5
6			none	SOUND6
7	✗		3	SOUND7
8		✓	3	SOUND8
9			none	
10			none	
11			none	
12			none	

The summary text in the lower part of the window shows the number of buttons assigned to each group.

Play groups .. G3:5

SOUND2	SOUND3	SOUND4	SOUND5	SOUND6	SOUND7	SOUND8
2dG3 00:12	3dG3 00:12	4d 00:12	5dG3 00:01	6d 00:12	7dG3 P00:09	8dG3 P00:04

As an alternative to setting up the Play Groups in this dialog box the groups can be assigned from the main screen by shift+ctrl right-clicking on a button

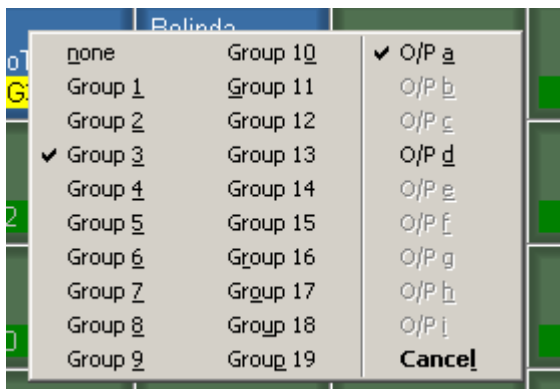

If the Groups and Master/Slave links are disabled then the group selections will be greyed out

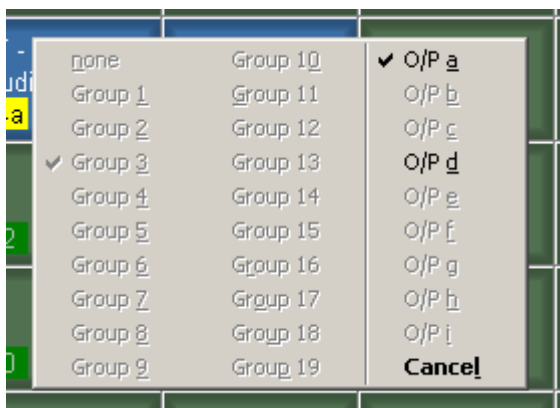

## Buzzer Groups

In the above description of Play Groups there were 25 exclusive groups numbered 1..25, and 4 buzzer groups with legends A..D

Buttons assigned to Buzzer Groups act slightly differently to Play Groups, in that if any button that belongs to a buzzer group is played all other members of that buzzer group are prevented from being played for the duration of a timeout period.



✓ zero	10s
0.5s	15s
1.0s	20s
1.5s	25s
2.0s	30s
2.5s	35s
3.0s	40s
3.5s	45s
4.0s	50s
4.5s	99m

The intended use of this is in "Bell and Buzzer" rounds in quiz shows where only the first person in a team to press the the 'bell' or 'buzzer' actually triggers the sound effect, other presses are locked out.

This Buzzer Group mode of operation is only available when the Play command is received from an external source ie GPI or Midi, HotKey and mouse click operation is not affected by the presence of Buzzer Groups.

The Buzzer Group timeout can be set between zero and 99 minutes, with the longer timeouts it will often be necessary to reset the timeout period, say for the start of the next quiz round. The timeouts can be reset either by toggling the GPIs off/on or by use of the special play group 25.

Play group 25 is shown in the group selection windows as 25! meaning that it acts differently from groups 1..24.

When any button in group 25 is played directly (not with a Play Next) it will play and also clear the Buzzer Group timeouts. In practice this could be a button loaded with silence and operated by an external GPI triggered by someone supervising the quiz game.

## Play Stack

Play group 24 has a secondary function in that it will fade out any tracks playing in the [Play Stack](#) window.

## Display

The Groups and Master/Slave Links can be enabled via the [Options](#) menu or by clicking the status panel below



The button displays change to indicate any links, here button 10 has an M suffix to the button number indicating it is a Master and buttons 2, 5 and 6 have an S (Slave) suffix.

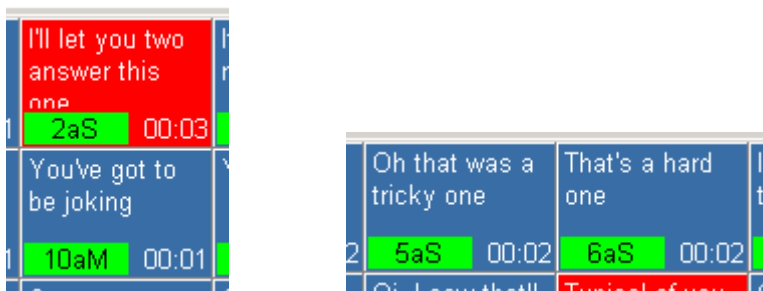

The status bar gives more information showing which Link the Master or Slave buttons are acting on.



### Voice Over

Voice Over mode is a special case of Master/Slave links where the gain of the Play Slave/s is reduced under control of the Master track - Stop slaves have no meaning in this mode and will be deleted.

The Slave track/s would be already playing and when the master 'voice over' track is played the gain of the slave/s will be reduced using the fade time and law of the master track - this means the Fade In and Fade Out of the master track must be non-zero.

To convert a Master/Slave link to be a VoiceOver link:-

First select an existing link - in this case #17 that has a master button 35 and one play slave button 34

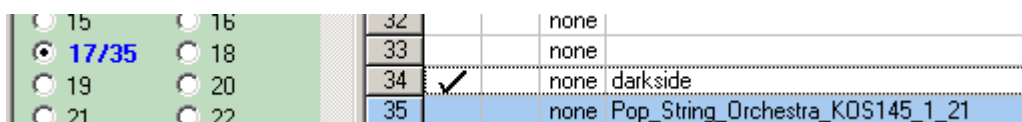

Right-click the link number - the link must be assigned a Master button for the popup options to be displayed

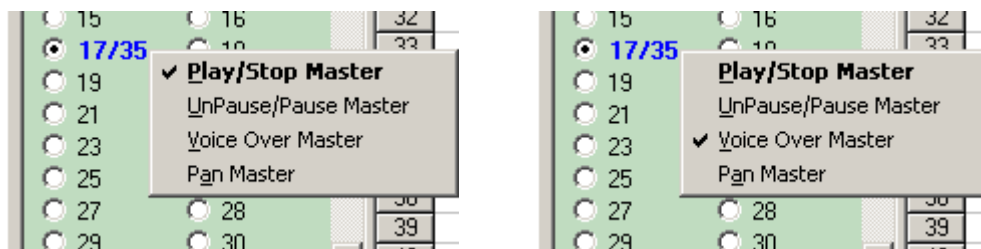

Check the Voice Over master option, at which point the link number will be underlined and the 'tick' in the play column will change to a fade down/up image.

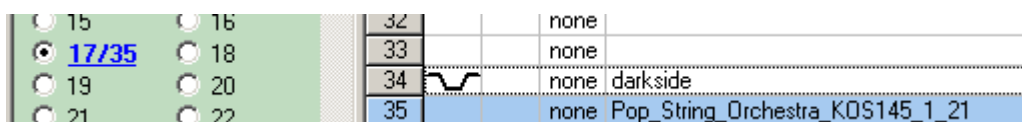

This means that track 34 will be faded down for the duration of the master track 35

The amount of gain reduction is set on each individual slave via the [Audio](#) button menu

When the Master/Slave setup window is closed a check is made of the buttons acting as Voice Over masters, if any have zero Fade In or Fade Out times a warning prompt box will appear indicating which buttons have to be modified.

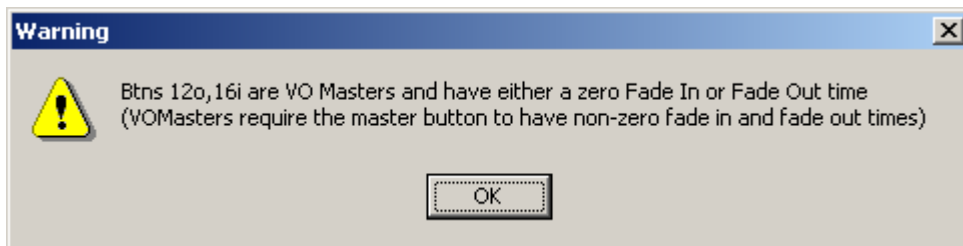

## AutoPan

The AutoPan feature allows one or more slave buttons to have their Pan setting modified under the control of a Master button.

In a similar way to the Voice Over mode described above the pan transition is triggered by the Fade In and Fade Out of the Master track.

For AutoPan the starting point is the normal Pan value defined in the Audio Setup dialog, the end value is an alternative value defined in the [Audio Setup](#) dialog by right-clicking the pan bar.

The AutoPan mode is selected by right-clicking the appropriate Link number and checking Pan Master

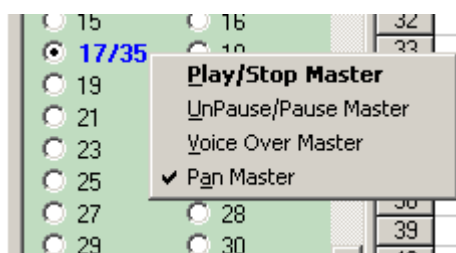

The selected play slave entries will have a double headed arrow displayed indicating that button is now an AutoPan slave.

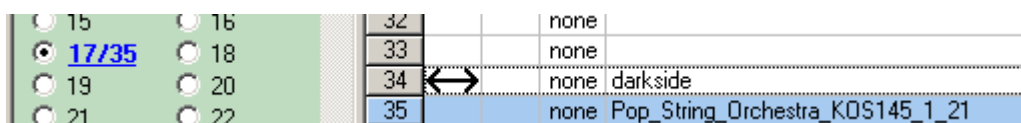

## UnPause/Pause

The UnPause/Pause mode is selected by right-clicking the appropriate Link number and checking UnPause/Pause Master

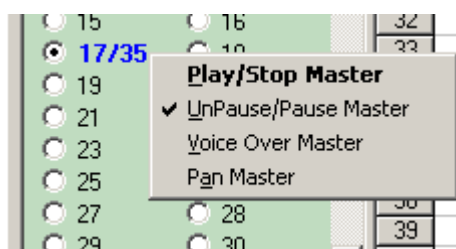

The selected stop slave entries will have a double line displayed indicating that button is now an Pause slave and similarly the selected Play slaves will have a double line with diagonal cross indicating the button is an UnPause slave

<input type="radio"/> 15	<input type="radio"/> 16	32	none
<input checked="" type="radio"/> 17/35	<input type="radio"/> 18	33	none
<input type="radio"/> 19	<input type="radio"/> 20	34	# none darkside
<input type="radio"/> 21	<input type="radio"/> 22	35	none Pop_String_Orchestra_KOS145_1_21

### Link Diagrams

With a complex set of Master/Slave links it is often difficult to establish which buttons are linked, an example is shown below. The Master Slave setup dialog window can provide the information but not in a readily useful format.

	4	sample_3 5aS 00:04	temp 6aS 00:09	7
sample_7 14aMS 00:04	sample 15aM 00:04	sample 16aM 00:04	sting 17aS 00:04	
s 24aMS 00:04	sample 25aM 00:04	sample_9 26aS 00:04	WoneCouple 27aS 00:03	
34	Hotel_California_high 35aS 00:52	sample_2 36aS 00:04	37	

A keyboard shortcut Ctrl+Shift+left mouse press can be used to show the master/slave links graphically, using the key combination on button 15 shows button 14 is a play slave (line is green).

		sample_3	temp	
4	5aS 00:04	6aS 00:09	7	
sample_7	sample	sample	sting	
14aMS 00:04	15aM 00:04	16aM 00:04	17aS 00:04	
s	sample	sample_9	WoneCouple	
24aMS 00:04	25aM 00:04	26aS 00:04	27aS 00:03	
	Hotel_California_high	sample_2		
34	35aS 00:52	36aS 00:04	37	

Testing the reverse link by clicking on button 14 shows a white line indicating it is a play slave from buttons 15 and 25, also button 14 is a play master to a button off the screen on another page (near horizontal green line).

Note the yellow border at the top of the page, this is drawn around the SpotOn screen to indicate the image is temporarily frozen whilst the graphics are displayed.

		sample_3	temp	
4	5aS 00:04	6aS 00:09	7	
sample_7	sample	sample	sting	
14aMS 00:04	15aM 00:04	16aM 00:04	17aS 00:04	
s	sample	sample_9	WoneCouple	
24aMS 00:04	25aM 00:04	26aS 00:04	27aS 00:03	
	Hotel_California_high	sample_2		
34	35aS 00:52	36aS 00:04	37	

Clicking on button 25 confirms some of the previous links and in addition displays button 36 as a Stop slave to button 25 (line is blue).

		sample_3	temp		
4	5aS 00:04	6aS 00:09	7		
sample_7	sample	sample	sting		
14aMS 00:04	15aM 00:04	16aM 00:04	17aS 00:04		
s	sample	sample_9	WoneCouple		
24aMS 00:04	25aM 00:04	26aS 00:04	27aS 00:03		
	Hotel_California_high	sample_2			
34	35aS 00:52	36aS 00:04	37		

A reverse interrogation of button 36 shows it is a stop slave to master button 25 (line is magenta)

		sample_3	temp		
4	5aS 00:04	6aS 00:09	7		
sample_7	sample	sample	sting		
14aMS 00:04	15aM 00:04	16aM 00:04	17aS 00:04		
s	sample	sample_9	WoneCouple		
24aMS 00:04	25aM 00:04	26aS 00:04	27aS 00:03		
	Hotel_California_high	sample_2			
34	35aS 00:52	36aS 00:04	37		

If instead of just using Shift+Ctrl+Left mouse press to display the existing links Shift+Ctrl+left mouse drag can create new links.

Below the Shift+Ctrl+Left mouse button has been dragged from button 52 to 54 drawing a thick red line, releasing the left mouse button as in 'drag and drop' will show a confirmation dialog.

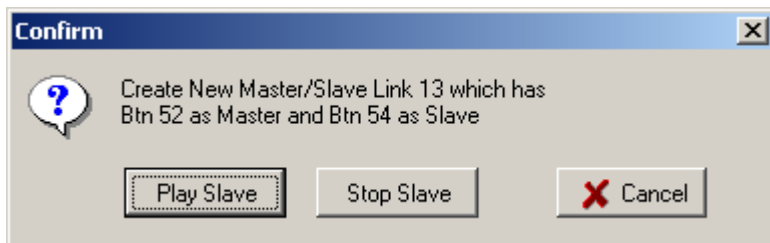
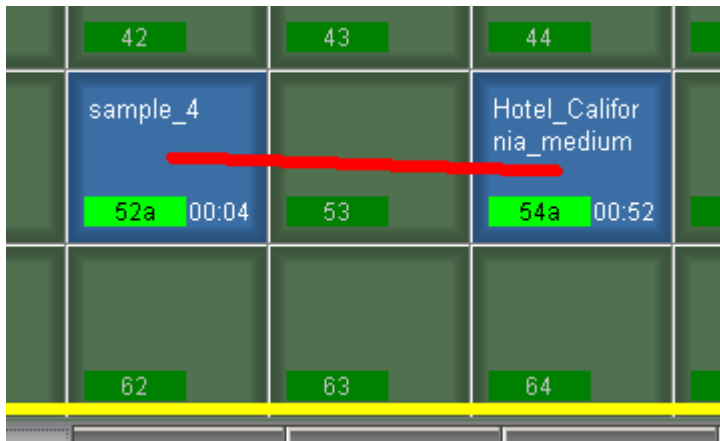

The next unused Master/Slave link will be selected for this new link - in this example link 13



Play and Stop links can also be deleted using the same drag/drop method, for example if the mouse is Shift+Ctrl drag and dropped between buttons 52 and 54 as below



then a prompt dialog will ask if the link is to be deleted.

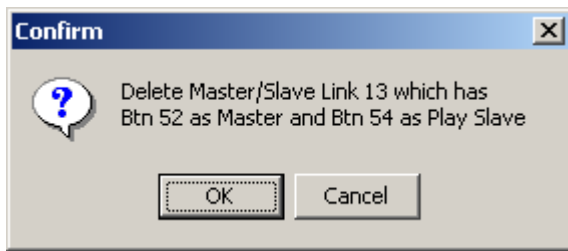

# Play Stack

A Play Stack is built into SpotOn and runs independently of the main SpotOn operation, the intended use is for playing out audience 'warm up' or interval music.

The stack can be set to play a set of tracks and fade out after a predetermined time or loop until stopped manually.

A fade out of the Play Stack can be triggered from the main SpotOn window by playing any button in [Group 24](#).

Tracks can be loaded by Ctrl+Left click drag (copy button mode) from the SpotOn buttons or by right-clicking an entry in the Play Stack and selecting Load/Insert.

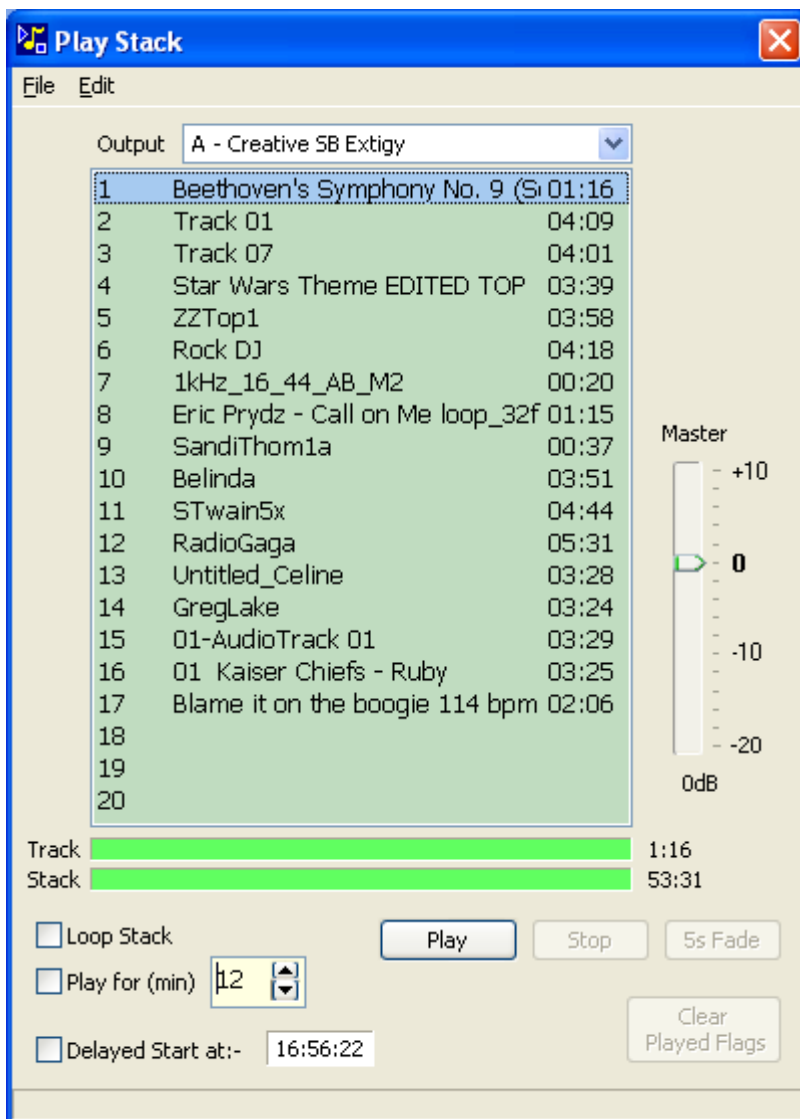

The image above shows 17 tracks loaded and track 1 highlighted, the track names are taken from the audio filenames and truncated to fit the screen, there is no option to change the displayed track name.

Clicking on Play will start playing the stack in sequence from the highlighted button, the two bargraphs below the track list show the time remaining for the track on the upper bargraph and the time remaining in the whole stack on the lower bargraph.

The track entry will be shown in red text when it is playing.

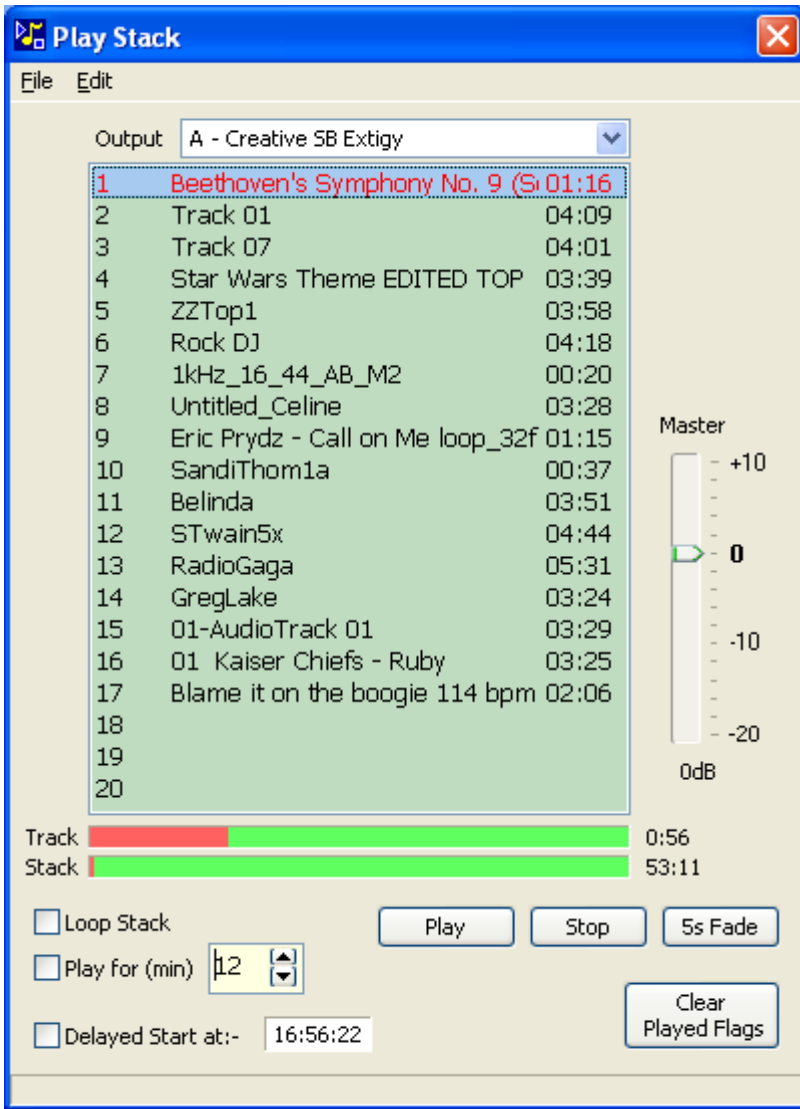

When the 'Loop Stack' checkbox is checked as shown below, the lower bargraph is disabled as the duration of a looped stack is infinite.

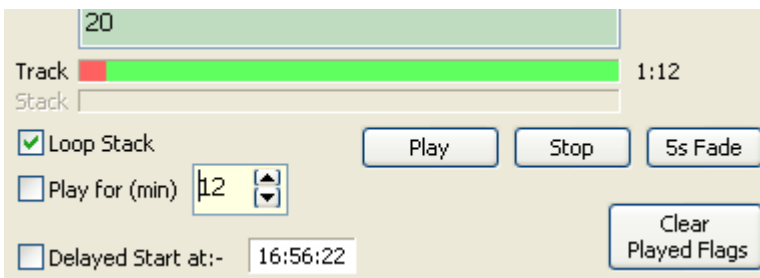

Tracks can be drag and dropped within the stack to change the playout order, in the example below, track 13 is being dragged and when dropped will be inserted above the track shown with yellow text and become track 8. Tracks currently numbered 8..12 will be moved down the stack one position and be renumbered.

1	Beethoven's Symphony No. 9 (S)	01:16
2	Track 01	04:09
3	Track 07	04:01
4	Star Wars Theme EDITED TOP	03:39
5	ZZTop1	03:58
6	Rock DJ	04:18
7	1kHz_16_44_AB_M2	00:20
8	Eric Prydz - Call on Me loop_32f	01:15
9	SandiThom1a	00:37
10	Belinda	03:51
11	STwain5x	04:44
12	RadioGaga	05:31
13	Untitled_Celine	03:28
14	GregLake	03:24
15	01-AudioTrack 01	03:29

Stack after drag/drop of track 13

1	Beethoven's Symphony No. 9 (S)	01:16
2	Track 01	04:09
3	Track 07	04:01
4	Star Wars Theme EDITED TOP	03:39
5	ZZTop1	03:58
6	Rock DJ	04:18
7	1kHz_16_44_AB_M2	00:20
8	Untitled_Celine	03:28
9	Eric Prydz - Call on Me loop_32f	01:15
10	SandiThom1a	00:37
11	Belinda	03:51
12	STwain5x	04:44
13	RadioGaga	05:31
14	GregLake	03:24
15	01-AudioTrack 01	03:29

Tracks in the stack can be freely rearranged whilst the stack is playing, the only restriction is not to remove the track currently playing.

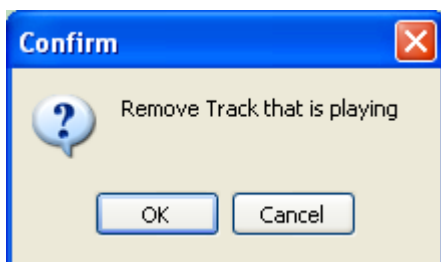

An internal flag is set as tracks are played out and the text background of the played track changes to grey, this is only an indication of the track already played and has no effect on the operation of the Play Stack.

The flags can be cleared by clicking on the 'Clear Played Flags' button

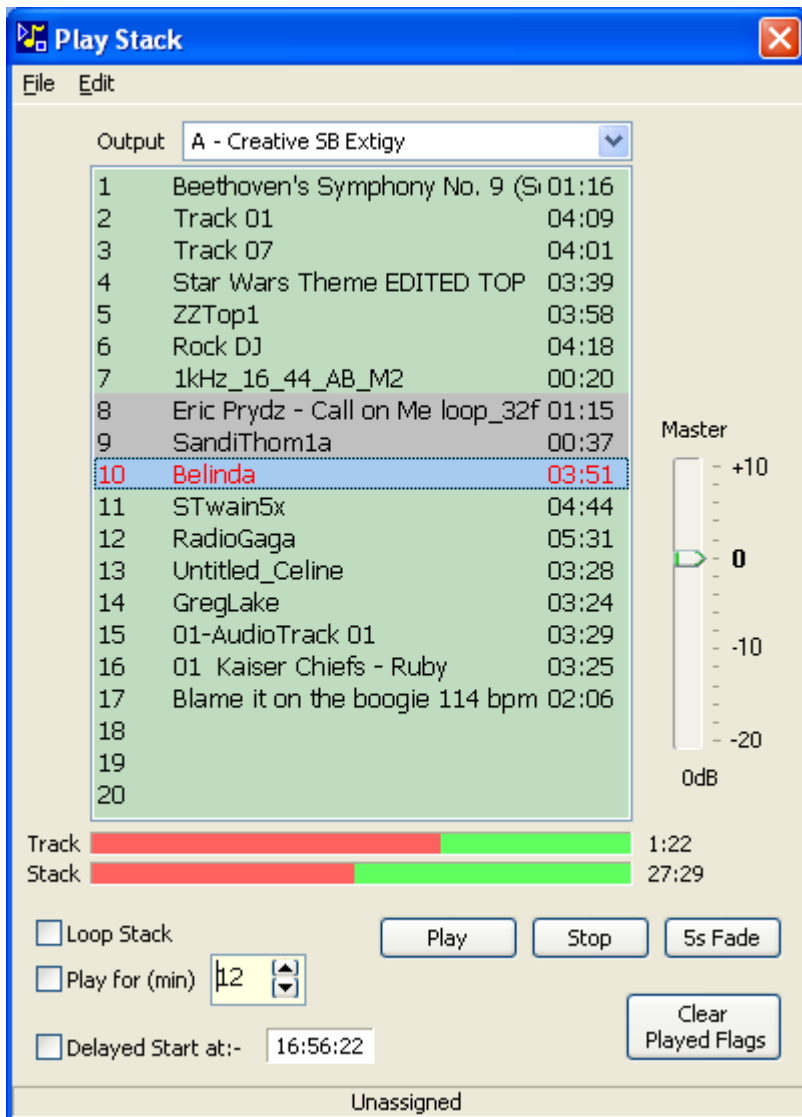

The Play Stack can be set to play for a defined length of time in the range 1..90 minutes, at the end of the time the track will fade out and stop.

This mode is set by checking the 'Play for (min)' checkbox and entering a value in the duration by typing directly or using the up/down buttons.

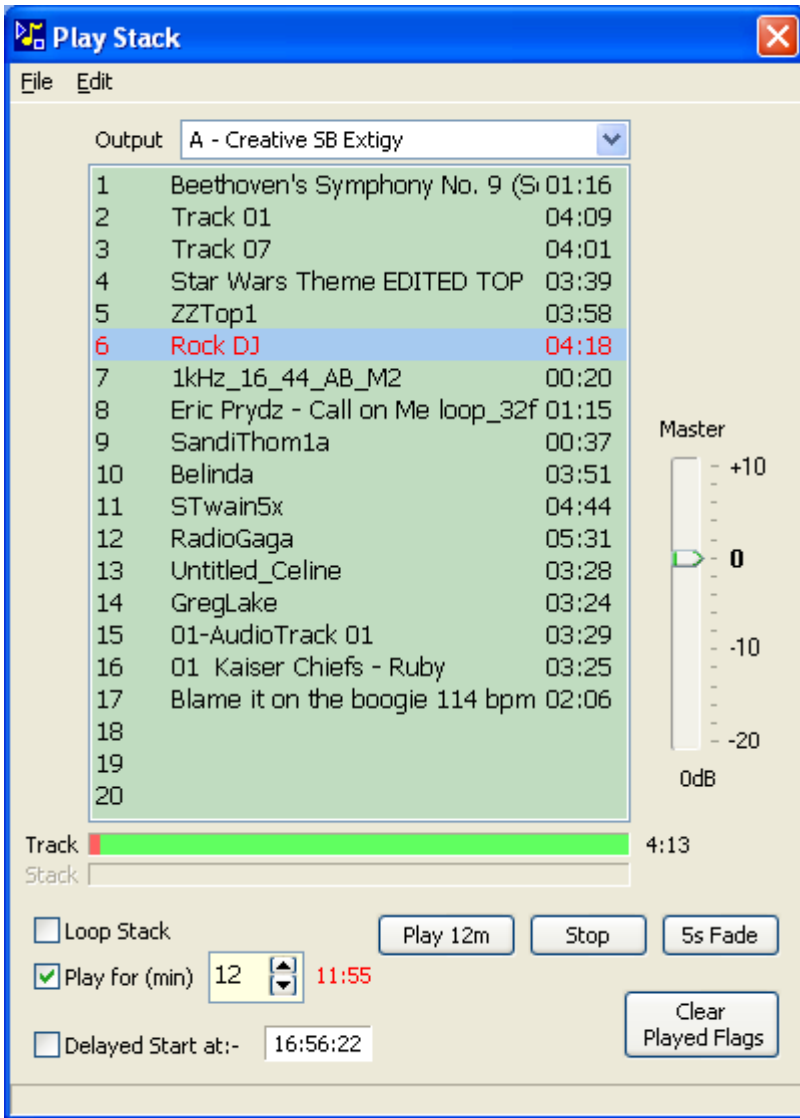

When the Play button is pressed a time remaining count down is shown in red text to the right of the duration.

The Stack Play button can be triggered from the PC clock.

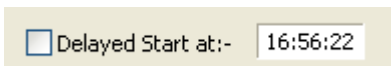

Right-clicking on the time panel displays an editor dialog

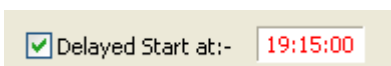
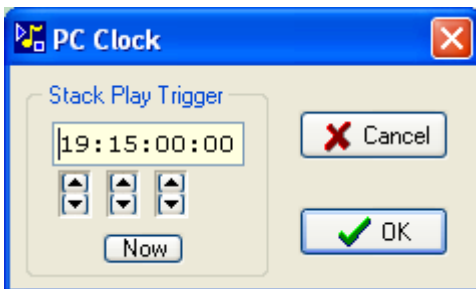

When active the start time text will be shown in red, at the point the start time is reached the stack will begin to play and the text will be shown as invalid and the checkbox cleared.

Delayed Start at:-

When the Play Stack window is closed it will remain active and has just been hidden, it can be reopened via the SpotOn Global|Play Stack menu.

If the Play Stack is playing a track and is then closed the track will continue to play and the SpotOn status bar will show a red/yellow flashing panel with the text 'Play Stack'

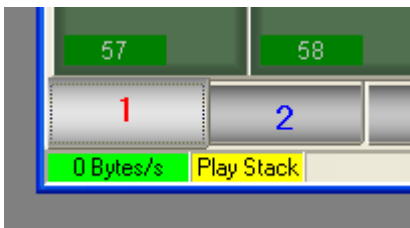
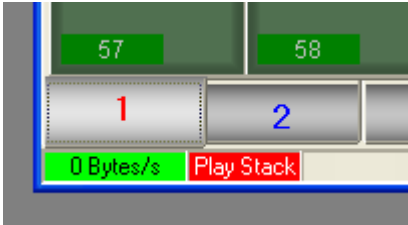

Clicking on the flashing status bar panel will reopen the Play Stack window

Playing a button in the main SpotOn window that is assigned to Group 24 will trigger a fade out of any Play Stack track currently playing.

none	Group 10	Group 20
Group 1	Group 11	Group 21
Group 2	Group 12	Group 22
Group 3	Group 13	Group 23
Group 4	Group 14	✓ Group 24+
Group 5	Group 15	Group 25!
Group 6	Group 16	Group A*
Group 7	Group 17	Group B*
Group 8	Group 18	Group C*
Group 9	Group 19	Cancel

## Menus

The File menu allows basic loading and saving of the Play Stack tracks and configuration, only the track filenames are saved and the Play Stack relies on the audio files staying in the same location on the local disc drives.

### Menus - File

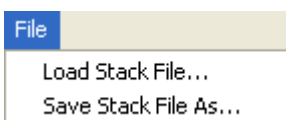

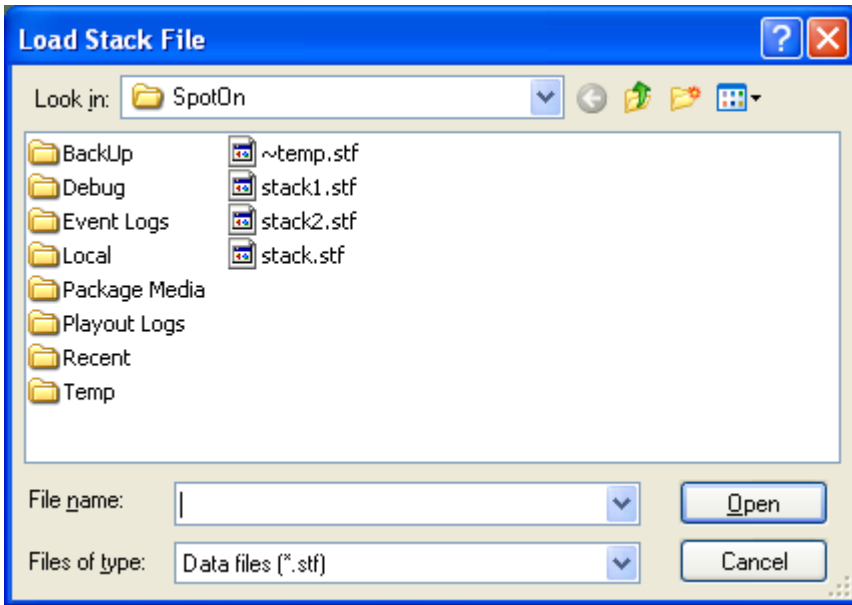

The Play Stack files are saved with the .stf file extension which may be associated with other programs, the only effect of this is that the icons shown along side the files will be different.

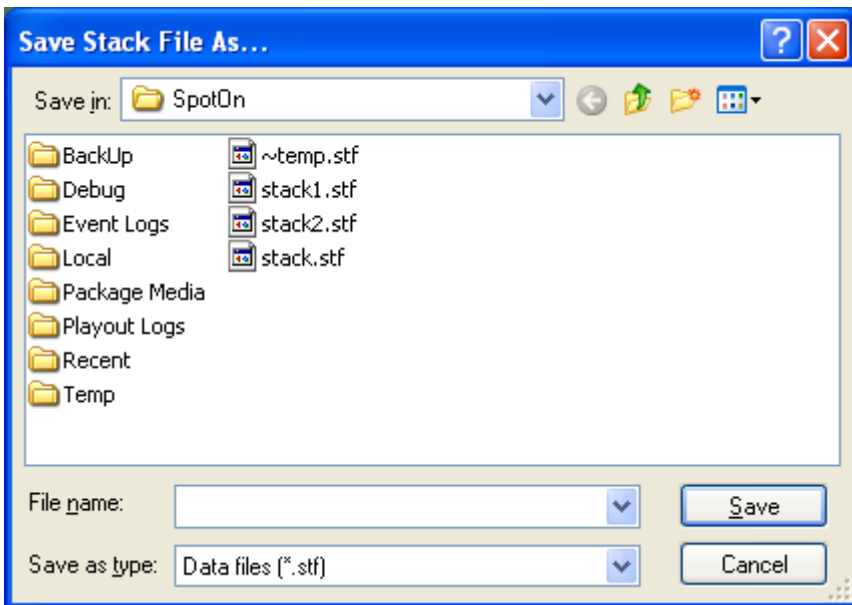

## Menus - Edit

The Edit menu gives 32 levels of Undo/Redo and two options that act on all tracks

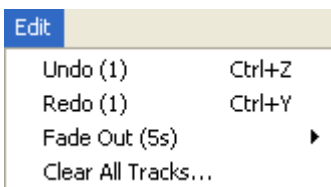

Fade Out will set the fade out time to any of the values shown below, this fade time is used at the end of a 'Play for' time or whenever the 'xs Fade' button is clicked and applies to all tracks.

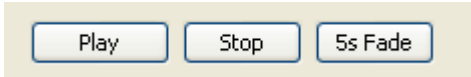
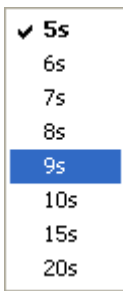

If the fade out is in progress the Fade Out button text will change colour to red and count down to the end of the fade time.

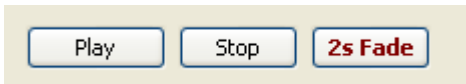

The 'Clear All Tracks' option will remove all tracks from the stack.

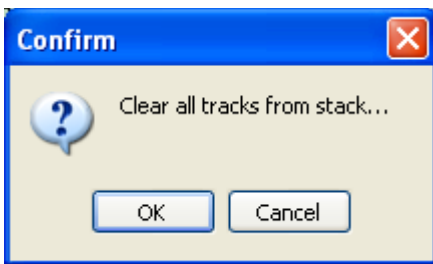

### Menus- Track

The right-click menu on the tracks allows changes to be made to the individual entry.

Right-clicking on a blank track offers the load option.

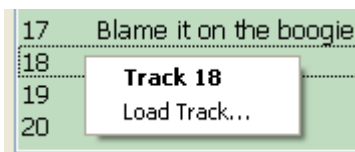

Play Stack uses the same default folder locations as SpotOn, however only \*.WAV files can be loaded.

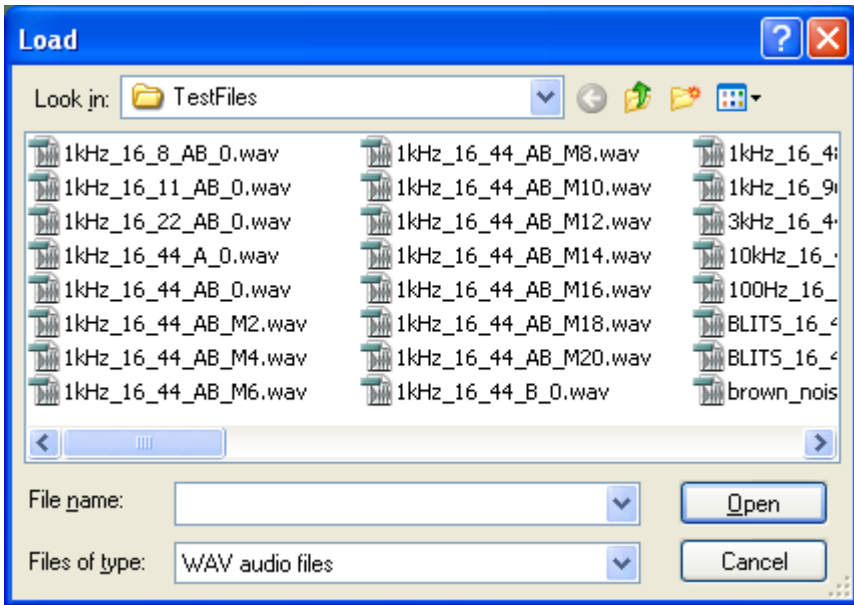

Right-clicking on an existing track will offer more options.

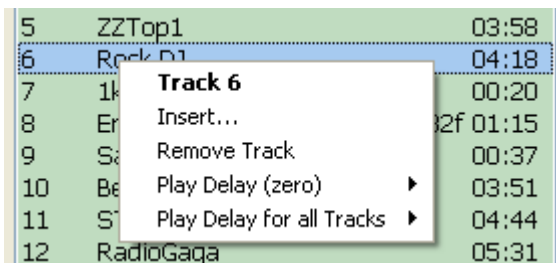

Insert will load an new track immediately above the highlighted track.

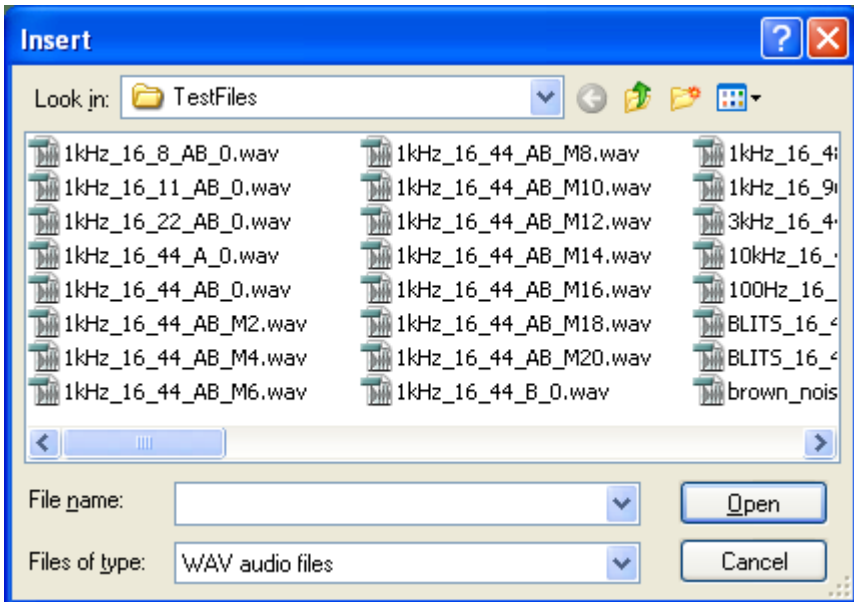

Remove Track deletes the track from the list and moves the remaining tracks to fill the gap.

Play Delay sets a pause before the track starts to play, this can be set on an individual track or globally using Play Delay for all Tracks

- ✓ zero
- 1s
- 2s
- 3s
- 4s
- 5s
- 6s
- 7s
- 8s
- 9s

If track 6 was set to have a Play delay of 7sec the entry in the list would show 'd7'

4	Star Wars Theme EDITED TOP	03:39
5	ZZTop1	03:58
6	d7 Rock DJ	04:18
7	1kHz_16_44_AB_M2	00:20
8	Untitled_Celine	03:28
9	Eric Prydz - Call on Me loop_32f	01:15

The Delay counts down when the track is played.

4	Star Wars Theme EDITED TOP	03:39
5	ZZTop1	03:58
6	d4 Rock DJ	04:18
7	1kHz_16_44_AB_M2	00:20
8	Untitled_Celine	03:28
9	Eric Prydz - Call on Me loop_32f	01:15

4	Star Wars Theme EDITED TOP	03:39
5	ZZTop1	03:58
6	d7 Rock DJ	04:18
7	1kHz_16_44_AB_M2	00:20
8	Untitled_Celine	03:28
9	Eric Prydz - Call on Me loop_32f	01:15

# Options Menu

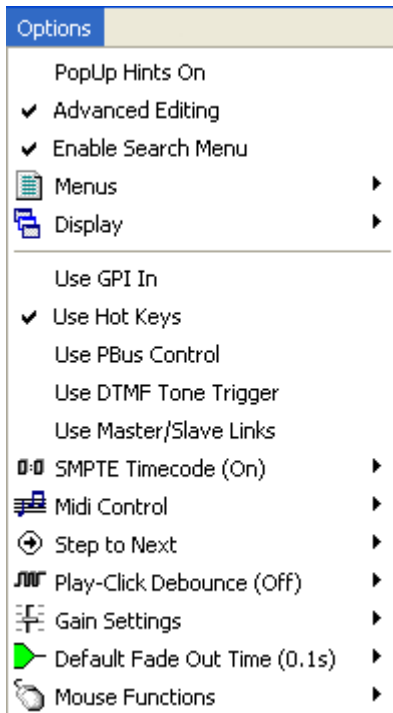

PopUp Hints On	toggle popup hint on/off
<a href="#">Advanced Editing</a>	allow editing of loaded WAV files
Enable Search Menu	enables Search menu item on main menu bar
<a href="#">Menus</a>	set main and popup menu options
<a href="#">Display</a>	general display options
Use GPI In	enable <a href="#">GPIs</a> from game port
<a href="#">Use Hot Keys</a>	show button hot keys
<a href="#">Use PBus Control</a>	enable remote control of SpotOn via a PBus serial link
Use DTMF Tone Trigger	enable triggering from <a href="#">external DTMF tones</a>
Use Master/Slave Links	enable <a href="#">master/slave links</a>
SMPTE Timecode	enable int/ext <a href="#">SMPTE LTC timecode</a> to trigger buttons directly and via
<a href="#">Midi Control</a>	Midi enabling options
<a href="#">Step to Next</a>	enable juke box mode
Play-Click Debounce	use hold off time between touchscreen presses
<a href="#">Gain Settings</a>	set overall gain offset and fade in/out depth
Default Fade Out Time	set fade on all subsequently loaded tracks
<a href="#">Mouse Functions</a>	change function of mouse buttons

## Advanced Editing

When this item is checked it allows the user to edit the audio data file being used by SpotOn, a warning message box is shown prior to any editing operation reminding the user that this mode is active.

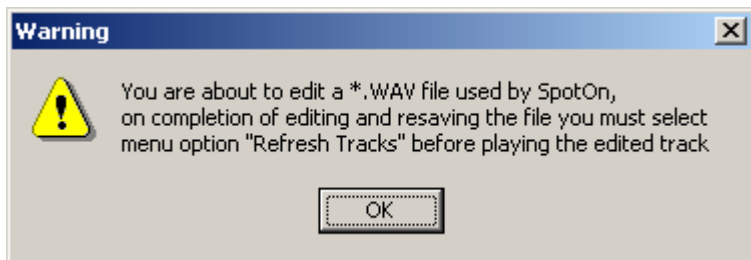

## Menus

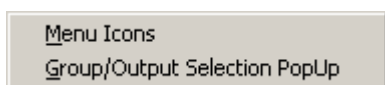

Menu Icons will toggle menu graphical icons on/off

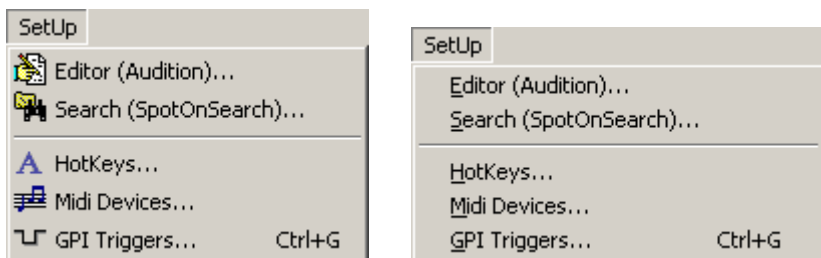

The Group/Output selection option changes the format of the button popup menu when a button is shift+ctrl right-clicked, with the option unchecked the full range of Group assignment is available.

✓ none	Group 10	Group 20
Group 1	Group 11	Group 21
Group 2	Group 12	Group 22
Group 3	Group 13	Group 23
Group 4	Group 14	Group 24+
Group 5	Group 15	Group 25!
Group 6	Group 16	Group A*
Group 7	Group 17	Group B*
Group 8	Group 18	Group C*
Group 9	Group 19	<b>Cancel</b>

With the item checked only Groups 1..19 are available for selection but in addition the output device can now be assigned to any of the first nine output devices.

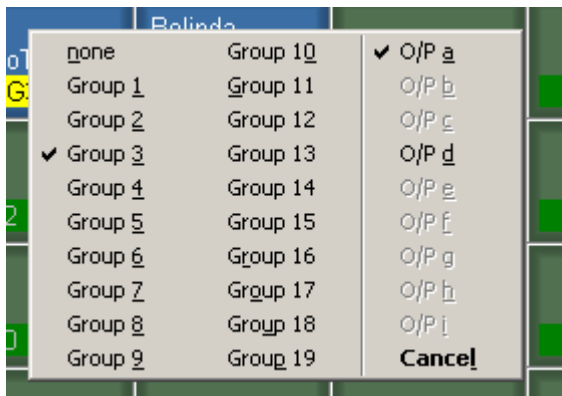

## Display

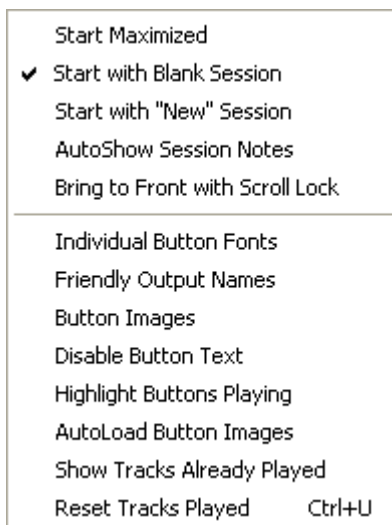

Start Maximised

[Start with Blank Session](#)

[Start with 'New' Session](#)

Auto Show Session Notes

[Bring to Front with Scroll](#)

Individual Button Fonts

Use Friendly Output Names

[Button Images](#)

Disable Button Text

[Highlight Buttons Playing](#)

AutoLoad Button Images

[Show Tracks Already Played](#)

Reset Tracks Played

on start up display is maximised to full screen, only when loading Blank SpotOn starts without loading previous session

SpotOn loads a default template session

show notes window on opening sessions

bring main window into focus whenever Scroll Lock is pressed

allows Trackname font to be set separately for each button

use names defined in [Output Device Assign](#)

allows bitmap images to be shown on buttons

removes all text from all buttons allowing button images to be seen in draws flashing corners on the buttons that are playing

automatically loads button images associated with audio files

indicate tracks that have been played in this session

clear Tracks Played indications (Ctrl+U)

### Display - Start with Blank Session

Instead of loading a temporary file on start up to restore the state of the program to be the same as when it was last shut down, this option when checked loads a blank session file.

## Display - Bring to Front with Scroll Lock

Hotkeys will only trigger SpotOn buttons when SpotOn is the active application, for instance if Adobe Audition is being used and the SpotOn hotkey "F1" is pressed the key press will be handled by Audition and not SpotOn.

In order to ensure that SpotOn is the active application before using hotkeys the Scroll Lock key can be used to make SpotOn active.

It is recommended that a double press of Scroll Lock is used so that the Scroll Lock state is left unchanged, very few applications make use of the Scroll Lock state but some unusual behaviour may be noticed when navigating spreadsheets if Scroll Lock is on.

## Display - Individual Button Fonts

With the Individual Button Fonts option checked the font used to display the Trackname on each button can [changed independently](#).

## Display - Button Images

Normally a button consists of a flat or shaded edge plain colour background with text and symbols drawn ontop



Images can also be used as the button background

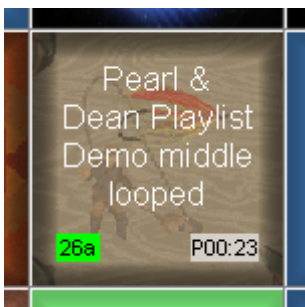

The images are enabled by this menu option and the specific image is allocated to the button via the button right-click [Display properties](#) dialog.

## Highlight Buttons Playing

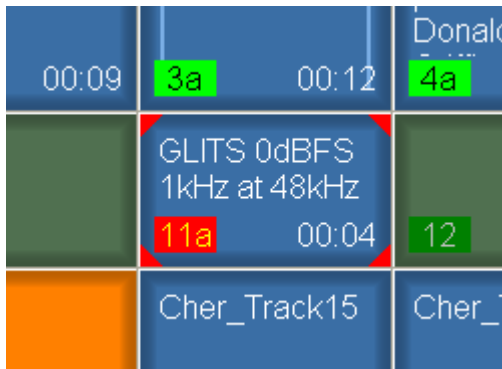

In addition to the flashing button number the corners of the button can flash in sync with the button number.

## Show Tracks Already Played

With this option checked the colours of the buttons played will be set to black, so indicating those tracks already used. The button colours can be restored by using the Reset Tracks Played option or the Ctrl+U keyboard shortcut.

Segment of screen before any track is played



Same segment after playing buttons 2,4,15,18,25 and 28



## Hot Keys

Each button can be assigned a hot key so that individual tracks can be played out directly from the keyboard, this option enables the assigned HotKeys.

The HotKeys as assigned to buttons via the [Button right-click menu](#)



## SMPTE Timecode



The options are to enable/disable triggering from all SMPTE timecode sources and to use the [Timecode Trigger List](#)

## Step To Next Track

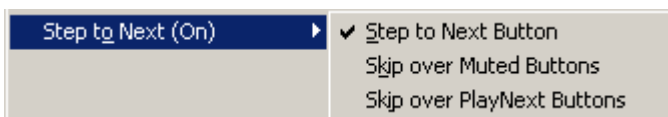

This allows consecutive tracks to be played out by pressing the spacebar or GPI/Midi signals, when this option is selected the track number of the active button will be shown with a white background or the button will have white diagonal corners. The active button can be changed by navigating around the page with the cursor keys, left, right, up and down arrow keys along with Home and End



Pressing the spacebar will play the currently active track and make the next button active ready for payout.

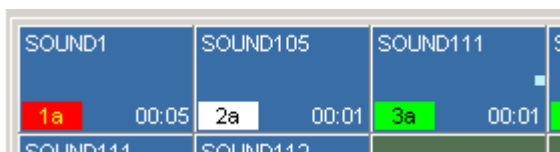

This newly active button can be played at any time by pressing the spacebar, see [GPI Assignments](#) for triggering function externally.

if Skip over Muted Buttons is checked then buttons that are muted (have the muted box checked in audio setup dialog box) will be ignored when playing out using the spacebar and the next non-muted button will be selected as the next to play.

Similarly Skip over PlayNext buttons will ignore buttons in a PlayNext sequence as these buttons will be played automatically when the first button in the sequence is played.

The next button to play can be highlighted via the [Options|Display|Highlight](#) Step to Next option.

Home and End keys will position the highlighted key to the top left or bottom right buttons respectively.

When a button is assigned the virtual HotKey '=' it can be used as an alternative Home position, pressing Alt+Home will scan backwards through the buttons and move the Step to Next highlight to the previous button assigned '=' as a HotKey.

### Play-Click Debounce

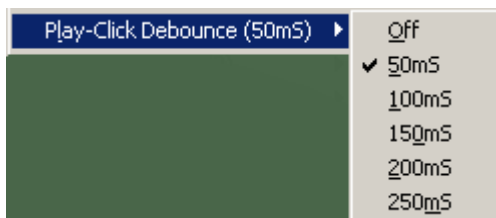

When using a mouse left-click or touchscreen press to play a track, SpotOn will respond to every action. This can present a problem when using a touchscreen in that the "button" may not be pressed cleanly with the possible consequence of a double press being detected.

The debounce options in this menu prevent the button being pressed in the XXmS after the initial press so masking out any secondary/unintentional presses.

### Default Fade Out Time

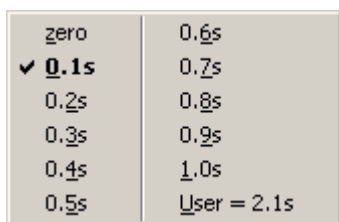

To minimize the abrupt audio transition when tracks are stopped before the end a default fade time can be used, this setting applied to all subsequently loaded tracks.

A setting of zero will produce audible clicks if the signal level is significant at the time the track is stopped, a worst case is shown below with full level tone stopped mid cycle.

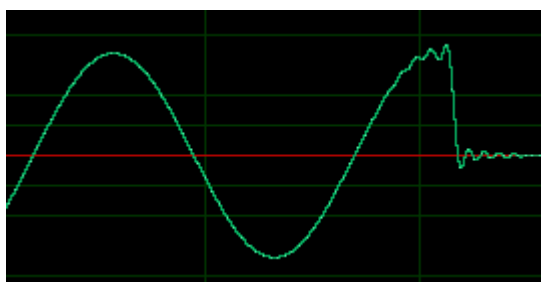

A range of value 0.1s to 1.0s are available along with a user defined value that is saved with the session data.

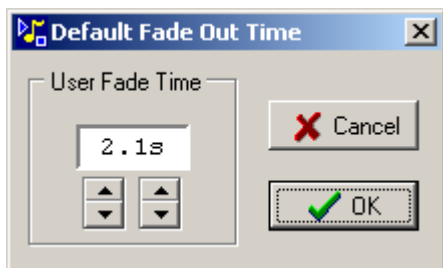

## Midi

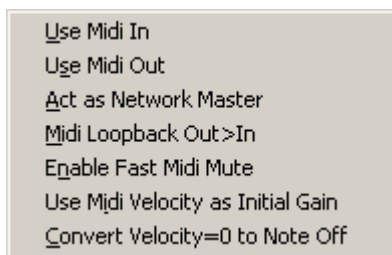

Use Midi In  
 Use Midi Out  
 Act as Network Master  
 Midi Loopback Out>In  
 Enable Fast Midi Mute  
 Use Midi Velocity as Initial Gain  
 Convert Velocity=0 to Note Off

respond to incoming Midi messages  
 generate Midi outgoing messages  
 send Midi out via Network link to a slave SpotOn computer  
 internally loop outgoing messages back to the input, without specialist option for handling very fast Midi In messages  
 use the Velocity data in Midi messages to set the initial gain  
 test midi message for zero velocity and translate into a Note

## Gain Settings

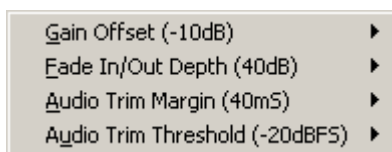

The overall gain offset of the audio played out by SpotOn can be set to 0dB or -10dB, when -10dB is selected the level of individual tracks can be increased by up to 10dB.

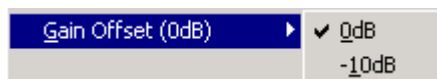

The depths of the Fade In and Out applied to tracks is globally set by this option

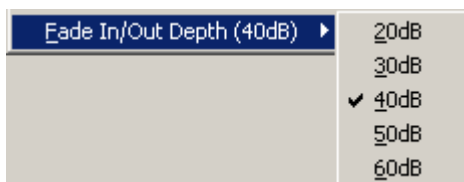

When using the AutoTrim feature the threshold for detecting audio can be set globally over the range -20dBFS..-50dBFS

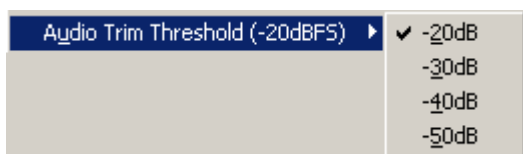

A modifier can be applied to the AutoTrim feature where the calculated In and Out points are expanded by a short time to include any leading or trailing transients.

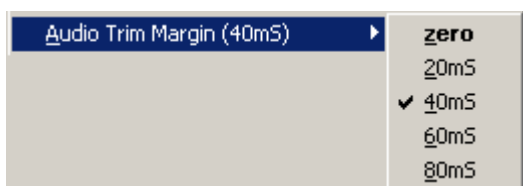

## Mouse Functions

The functions of the left, right and centre mouse buttons can be changed with this option

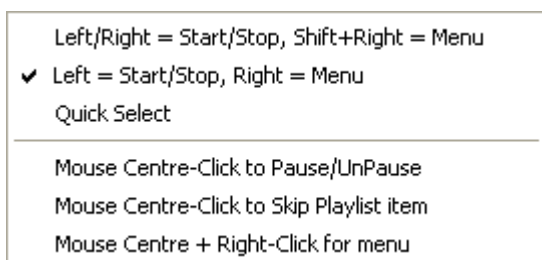

### Play/Stop:-

The default setting is alternate clicks of left mouse button to start and stop the track with the right mouse button used to bring up the popup menus.

If required this action can be changed to have the left and right mouse buttons start and stop the track respectively with Shift + right-click accessing the popup menus.

With the Quick Select option checked the mouse left/right button action can be changed by clicking on the [lower right hand panel](#) in the main window status bar.

### Pause/Skip/Menu:-

When using pointing devices with a centre button this can be assigned to a Pause/UnPause function, this only operates on tracks that do not contain a PlayList.

If the track does contain a PlayList the centre click can be set to cause the current PlayList section to move onto the next section on completion of the next loop, see [Advanced Operation](#)

As an alternative to using the keyboard Shift key the centre mouse button can be used to display the button menu.

Note that in some installations using a Keyboard, Video and Mouse (KVM) switch the mouse centre+right key combination is a shortcut to change the KVM selection.

# Info Menu

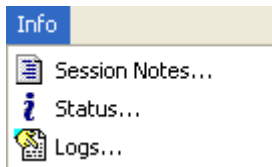

## Session Notes

Provides a free text entry note pad which is saved with the session file

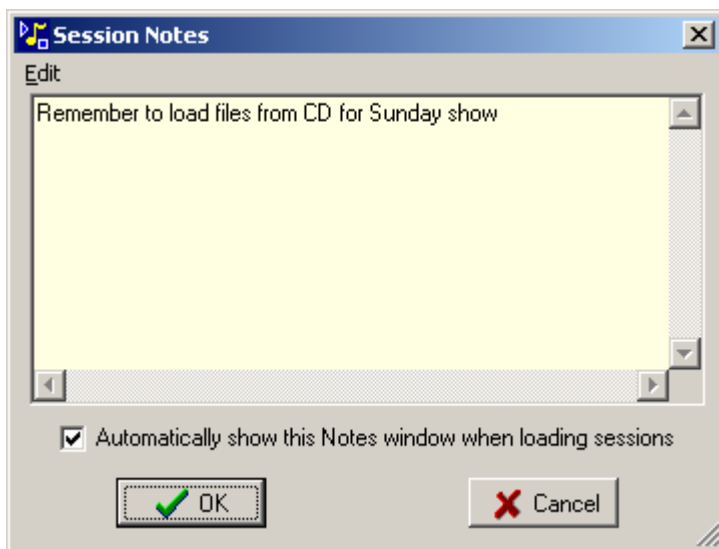

If the item in Options|Display|Auto Show Session Notes is checked then this window will be shown each time a session is loaded and the notes field is not blank.

The checkbox on this window can be unchecked to stop the window automatically showing for the remainder of the SpotOn session.

If the item in Options|Display|Auto Show Session Notes is unchecked, the notes window will not be automatically shown.

The notes field can be cleared using the menu item below.

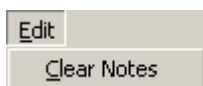

## Status

A selection of status information is listed in this panel only the first few items shown below will be of general use.

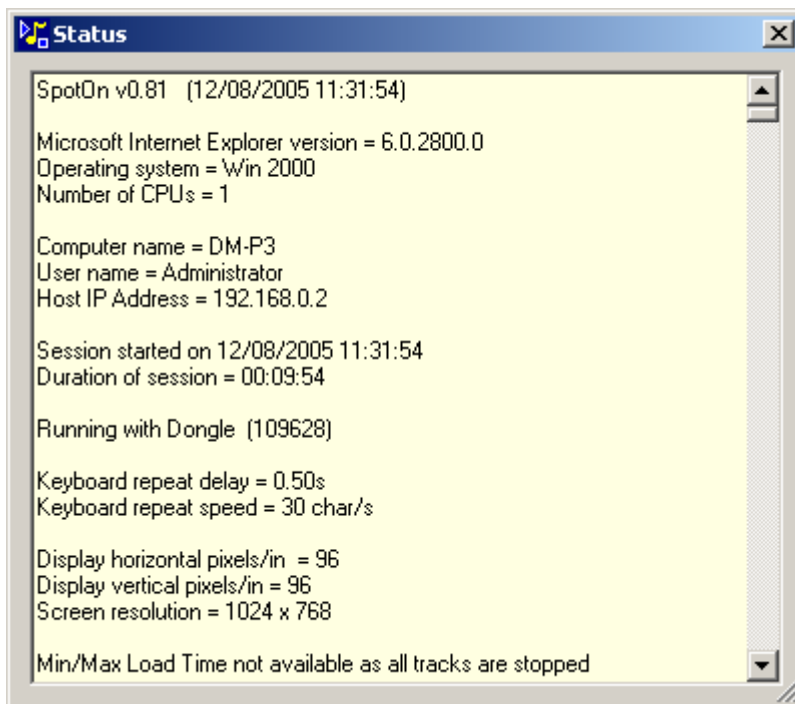

If is necessary to copy some of the status information, right-clicking on the display will offer the option to copy to the Windows clipboard either all the text or just the selected text.

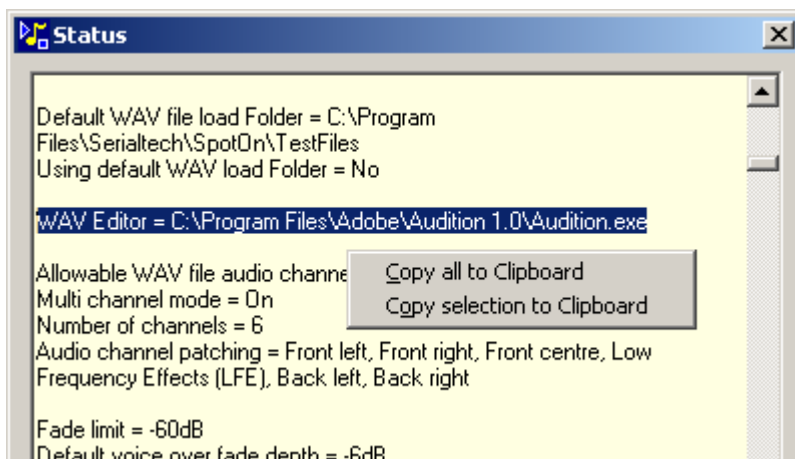
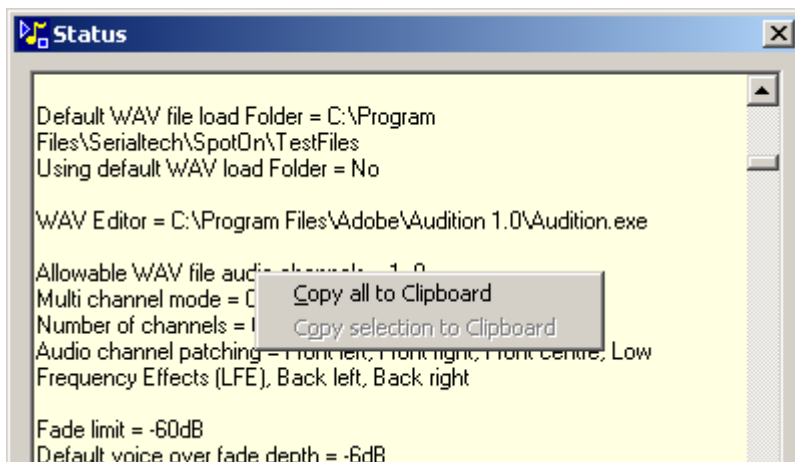

## Logs

A range of user activities are logged and can be viewed via this menu item, the activities are split into two pages - **Playout** and **Events**.

The **Playout** page shown below lists all the buttons that are played out against a timestamp along with other information describing the track and is intended for use with royalty payment logging.

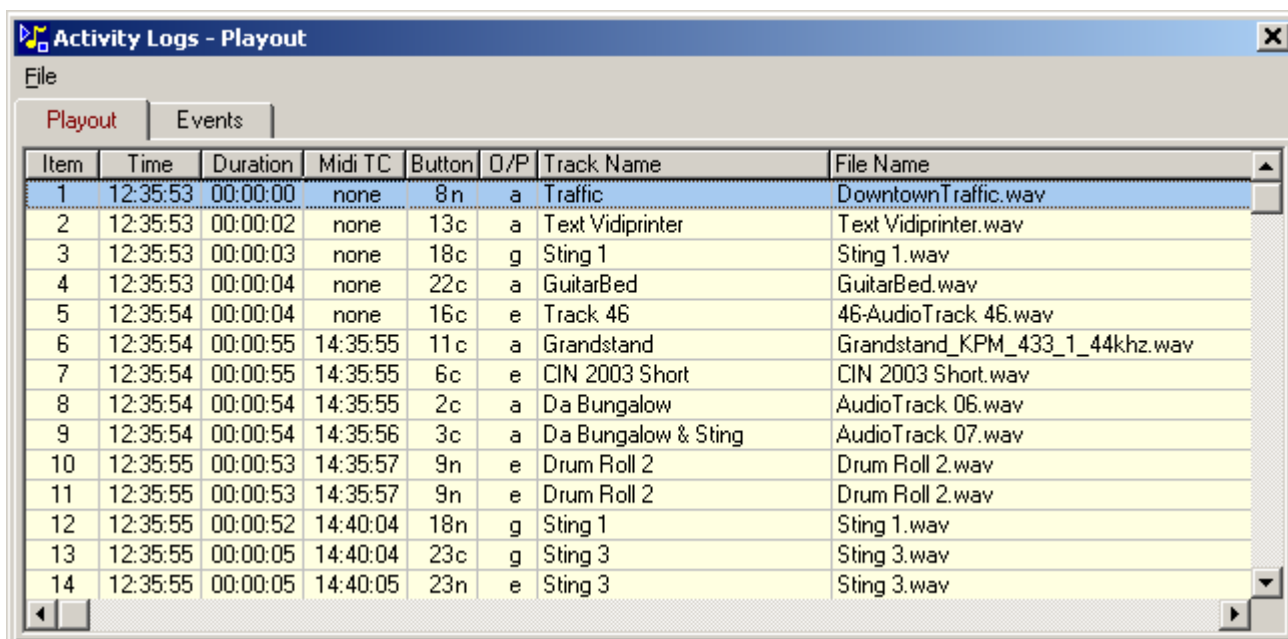

Item	Time	Duration	Midi TC	Button	O/P	Track Name	File Name
1	12:35:53	00:00:00	none	8n	a	Traffic	DowntownTraffic.wav
2	12:35:53	00:00:02	none	13c	a	Text Vidiprinter	Text Vidiprinter.wav
3	12:35:53	00:00:03	none	18c	g	Sting 1	Sting 1.wav
4	12:35:53	00:00:04	none	22c	a	GuitarBed	GuitarBed.wav
5	12:35:54	00:00:04	none	16c	e	Track 46	46-AudioTrack 46.wav
6	12:35:54	00:00:55	14:35:55	11c	a	Grandstand	Grandstand_KPM_433_1_44khz.wav
7	12:35:54	00:00:55	14:35:55	6c	e	CIN 2003 Short	CIN 2003 Short.wav
8	12:35:54	00:00:54	14:35:55	2c	a	Da Bungalow	AudioTrack 06.wav
9	12:35:54	00:00:54	14:35:56	3c	a	Da Bungalow & Sting	AudioTrack 07.wav
10	12:35:55	00:00:53	14:35:57	9n	e	Drum Roll 2	Drum Roll 2.wav
11	12:35:55	00:00:53	14:35:57	9n	e	Drum Roll 2	Drum Roll 2.wav
12	12:35:55	00:00:52	14:40:04	18n	g	Sting 1	Sting 1.wav
13	12:35:55	00:00:05	14:40:04	23c	g	Sting 3	Sting 3.wav
14	12:35:55	00:00:05	14:40:05	23n	e	Sting 3	Sting 3.wav

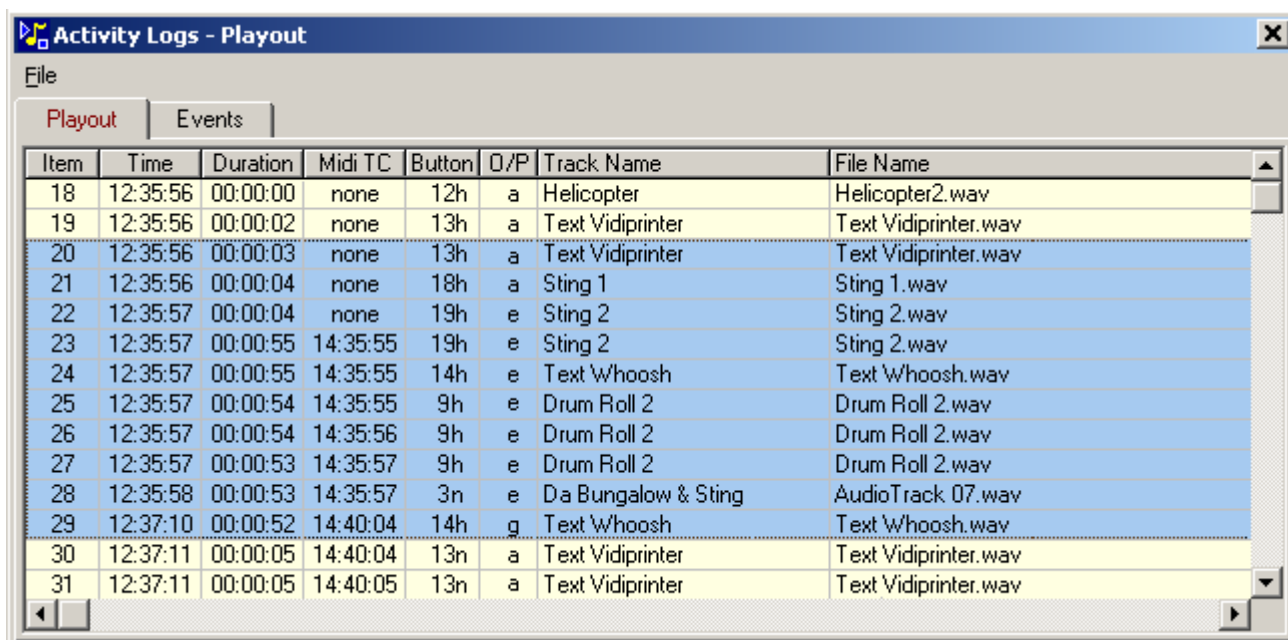

Item	Time	Duration	Midi TC	Button	O/P	Track Name	File Name
18	12:35:56	00:00:00	none	12h	a	Helicopter	Helicopter2.wav
19	12:35:56	00:00:02	none	13h	a	Text Vidiprinter	Text Vidiprinter.wav
20	12:35:56	00:00:03	none	13h	a	Text Vidiprinter	Text Vidiprinter.wav
21	12:35:56	00:00:04	none	18h	a	Sting 1	Sting 1.wav
22	12:35:57	00:00:04	none	19h	e	Sting 2	Sting 2.wav
23	12:35:57	00:00:55	14:35:55	19h	e	Sting 2	Sting 2.wav
24	12:35:57	00:00:55	14:35:55	14h	e	Text Whoosh	Text Whoosh.wav
25	12:35:57	00:00:54	14:35:55	9h	e	Drum Roll 2	Drum Roll 2.wav
26	12:35:57	00:00:54	14:35:56	9h	e	Drum Roll 2	Drum Roll 2.wav
27	12:35:57	00:00:53	14:35:57	9h	e	Drum Roll 2	Drum Roll 2.wav
28	12:35:58	00:00:53	14:35:57	3n	e	Da Bungalow & Sting	AudioTrack 07.wav
29	12:37:10	00:00:52	14:40:04	14h	g	Text Whoosh	Text Whoosh.wav
30	12:37:11	00:00:05	14:40:04	13n	a	Text Vidiprinter	Text Vidiprinter.wav
31	12:37:11	00:00:05	14:40:05	13n	a	Text Vidiprinter	Text Vidiprinter.wav

For the purposes of external analysis, a section of the list can be highlighted using **Shift+click** and **Ctrl+click** methods and saved to disc by right clicking in the grid.

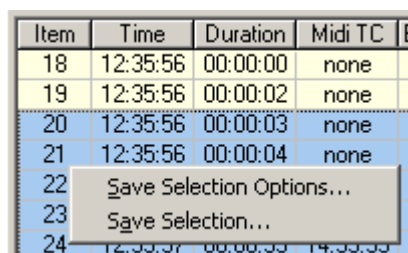

Item	Time	Duration	Midi TC	O/P	Track Name	File Name
18	12:35:56	00:00:00	none			
19	12:35:56	00:00:02	none			
20	12:35:56	00:00:03	none			
21	12:35:56	00:00:04	none			
22						
23						
24	12:35:57	00:00:55	14:35:55			

Save Selection Options...  
Save Selection...

Save Selection Options opens up a further dialog box

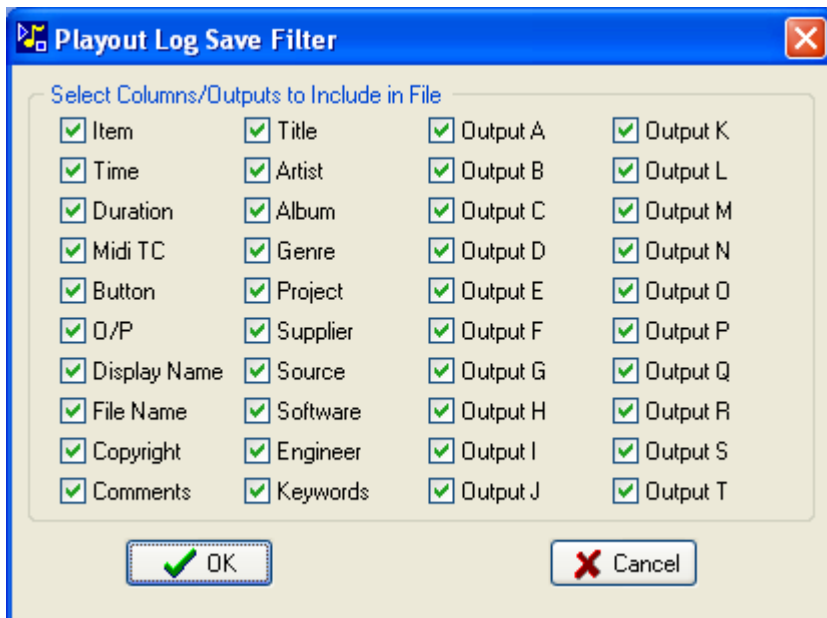

The Playout Log columns to be included in the file can be selected and also restricted to specific outputs, this option is only available when saving a highlighted selection of the current Playout Log which includes 2 or more lines.

The lower case suffices appended to the button numbers indicate the method by which the button was played, these can be any one of the following:-

- a Audio dialog Play
- b Position bar
- c Mouse Click
- d Play Delay
- e Fine Trim
- f DTMF Midi
- g GPI
- h Hotkey
- i TCP message
- j TCP Midi message
- k Timecode list
- n PlayNext
- o Midi loop back
- p PBus message
- q Wired Midi (ExtMidiLo..ExtMidiHi)
- r Midi test
- s Slave
- t Trim window Play
- u UDP message
- v Midi over UDP message
- x Start time archived to log
- y AutoPlay
- # WAV Preview dialog
- @ Click track
- [ Timecode stack
- ] unPause
- ( Preview
- ) Centre click
- ~ Effect setup dialog
- ^ Output Assign

The trigger codes can be listed via the Info|Trigger Codes menu

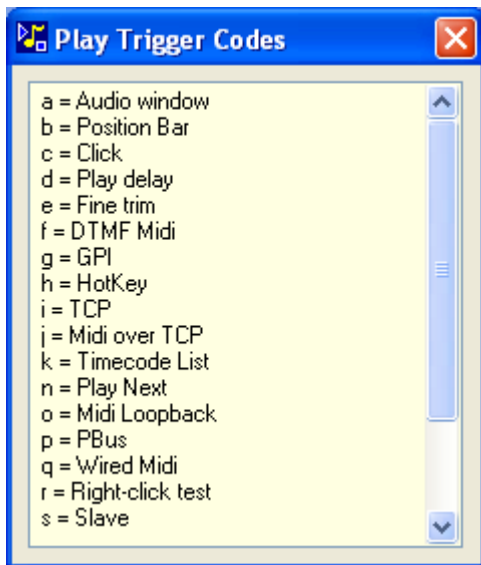
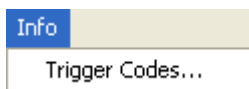

The duration column shows the length of time a track was playing before it was stopped, the column will show a value of ??:??:?? whilst a track is playing.

With long track or tracks that loop the duration cannot be entered for some considerable time after they were started, the consequence of this is that the duration may not be correctly entered into the archived Payout Logs. To avoid this there is an option in the [Engineering menu](#) forcing the archive to only be updated when all tracks are stopped, if this option is selected then the title bar will change as shown below.

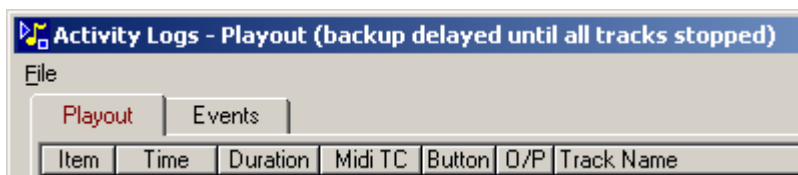

The Payout logs are saved to disc in the [default folder](#) with one log for each day SpotOn was used. The number of logs stored in the default folder is limited to 28, the oldest existing logs are deleted to maintain the maximum number of logs at 28.

However, Payout Logs can be stored in a user defined folder assigned via [File Folders](#), the number of files stored in the user defined folder is unlimited.

The second page shows other activities such as GPI in, Midi In/Out, files loaded/saved and system errors.

Item	Time	Action
1	12:34:34	All Stop
2	12:35:42	Package loaded - F:\Program Files\SpotOn\ITN\Simon Package.pkg
3	12:36:36	GPI In On
4	12:36:36	GPI-1 On at 12:36:36:632
5	12:36:36	GPI-1 On at 12:36:36:832
6	12:36:37	GPI-1 Off at 12:36:37:112
7	12:36:37	GPI-1 On at 12:36:37:192
8	12:36:37	GPI-1 Off at 12:36:37:453
9	12:36:37	GPI-1 On at 12:36:37:513
10	12:36:37	GPI-1 Off at 12:36:37:713
11	12:36:54	Midi In On
12	12:37:00	Midi In L:0/9/On at 12:37:00:456
13	12:37:04	Midi In L:3/13/On at 12:37:04:301
14	12:37:11	Midi Out 0:0/12/On at 12:37:11:221

The Event logs are saved to disc in the [default folder](#) with one log for each day SpotOn was used. The number of logs stored in the default folder is limited to 28, the oldest existing logs are deleted to maintain the maximum number of logs at 28.

The main menu has option to save to disk either the entire log or just the highlighted section and also access archived logs - this is more applicable to the Playout logs where tracks played a few days ago can be located.

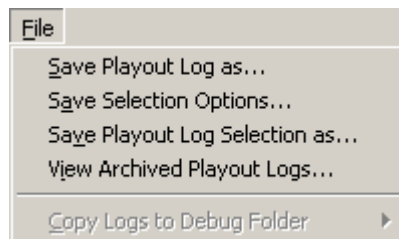
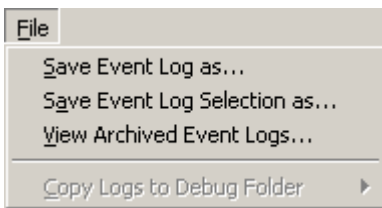

Both of the logs are automatically saved to disk when SpotOn closes.

The last item in the menu is 'Copy Logs to Debug Folder' this option is only enabled when in Engineering mode and is used to copy a selection of recent logs to a folder for debugging purposes, see [Debug Logs](#)

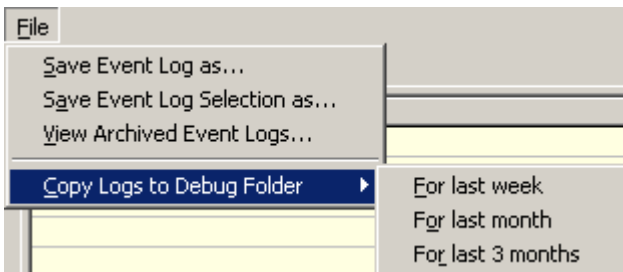

The SetUp menu Column options are only enabled whilst viewing the Playout log

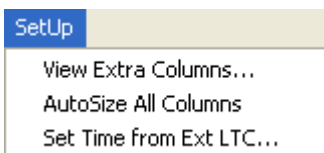

in SpotOn v0.96 and above the playout log can display additional metadata, the columns shown can be selected via the View Extra Columns option

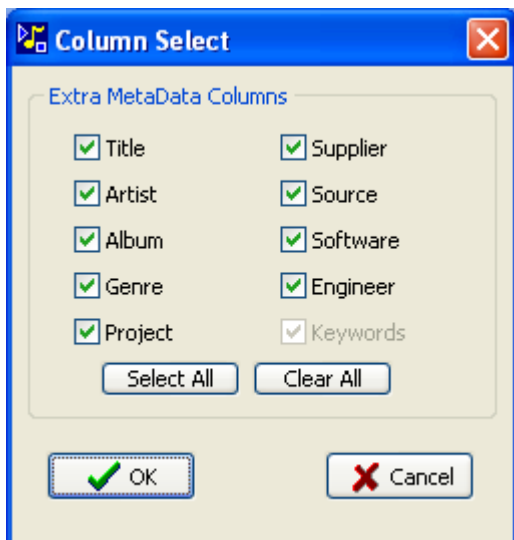

The width of the individual Playout log columns can be autosized by double clicking on the column header, alternatively all columns being shown can be autosized with the Autosize All Columns option

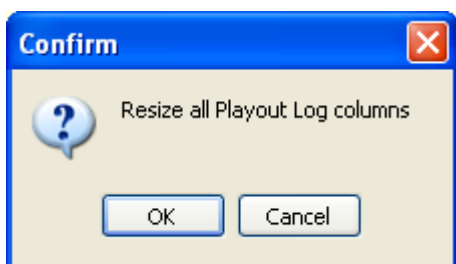

The timestamp applied to both the Playout and Event log entries is based on the PC clock, this can be set to the correct time by using the Windows Internet Time Server option or from an [external LTC signal](#)

## Local Files

### **This menu item has been disabled**

Each time SpotOn loads a button with an audio file located on a non fixed drive it copies the file to a local directory.

After sometime there may be files stored in this local directory that are redundant and can therefore be deleted, the file names coloured red are in use in the current session of SpotOn.

The items coloured green are not in use in the current session - but maybe used by others and be referenced in their data files.

The file Aaron.wav below is shown as not used but write protected and therefore cannot be deleted.

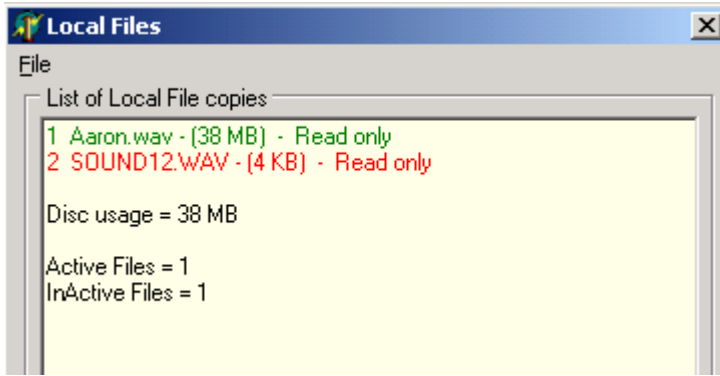

If the file was not write protected it would appear as below

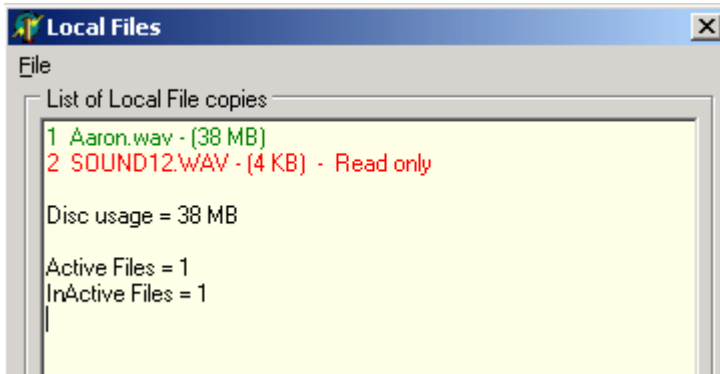

Using the File menu the unused files can be deleted from the Local directory

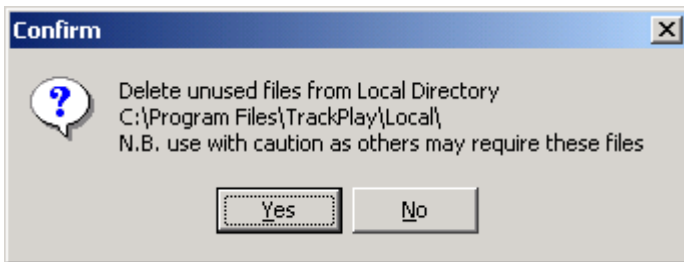
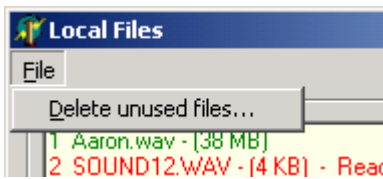

# Engineering Menu

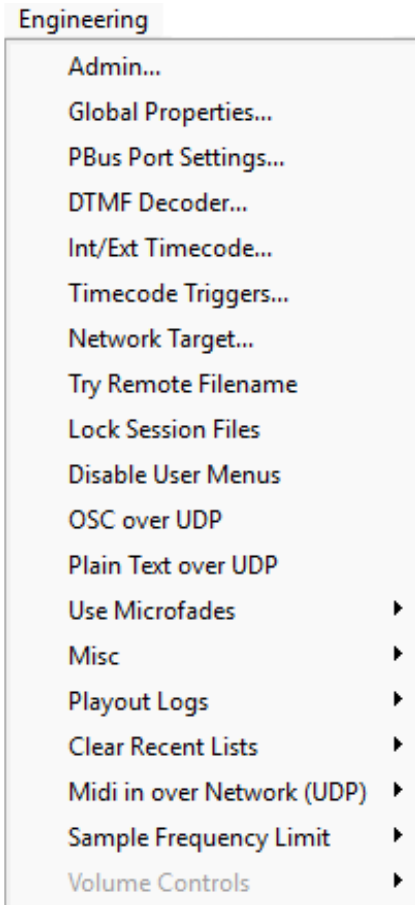

The Engineering Menu contains options to be set by an advanced user

<a href="#">Admin</a>	Administrator menu options
<a href="#">Global Properties</a>	Set range of property values
<a href="#">PBus Port Settings</a>	Settings for receiving PBus commands
<a href="#">DTMF Decoder</a>	Settings for receiving external DTMF tones
<a href="#">Int/Ext Timecode</a>	Input settings for SMPTE or Button timecode
<a href="#">Timecode Triggers</a>	Trigger buttons from a list of SMPTE timecodes
<a href="#">Network Target</a>	Assigns target computer address
<a href="#">Try Remote Filename</a>	search remote locations for audio file
<a href="#">Lock Session Files</a>	Set loaded track files to be read-only
<a href="#">Disable User Menus</a>	Disable menu items for simple playout operation
<a href="#">OSC over UDP</a>	Enable OSC commands
<a href="#">Plain Text over UDP</a>	Enable plain text commands.
<a href="#">Use Micro Fades</a>	Render precision fades for Fade Out and short Fade In durations
<a href="#">Misc</a>	Assorted Settings
<a href="#">Playout Logs</a>	Options for generating/copying playout logs
<a href="#">Clear Recent Lists</a>	Clear history lists in File menu
<a href="#">Midi In over Network</a>	Enables Midi messages received via a Network connection
<a href="#">Sample Frequency Limit</a>	Set highest sample frequency that SpotOn will allow in WAV files
<a href="#">Volume Controls</a>	Adjust levels of Windows volume controls for each output - option disabled

## Admin

Provides password protected access to the [Administrator](#) menu options

## Global Properties

The Global Properties option allows a large number of the menu options to be viewed and set within one dialog window.

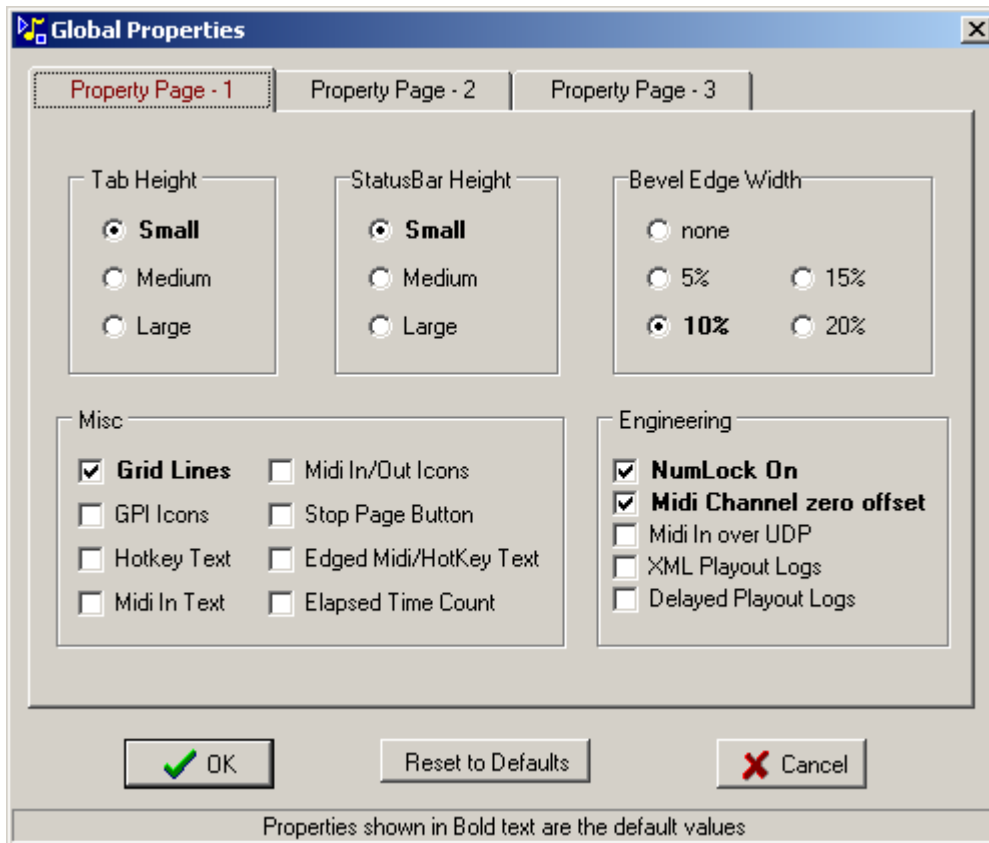

The default values are shown in bold text

The 'Reset to Defaults' button will set all properties on all pages to the default values.

The 4th property page is only accessible when Admin mode is enabled, this page is a slightly more sophisticated version of the [Output Assignment](#) dialog.

Initially the current output device configuration is shown in the right hand panel

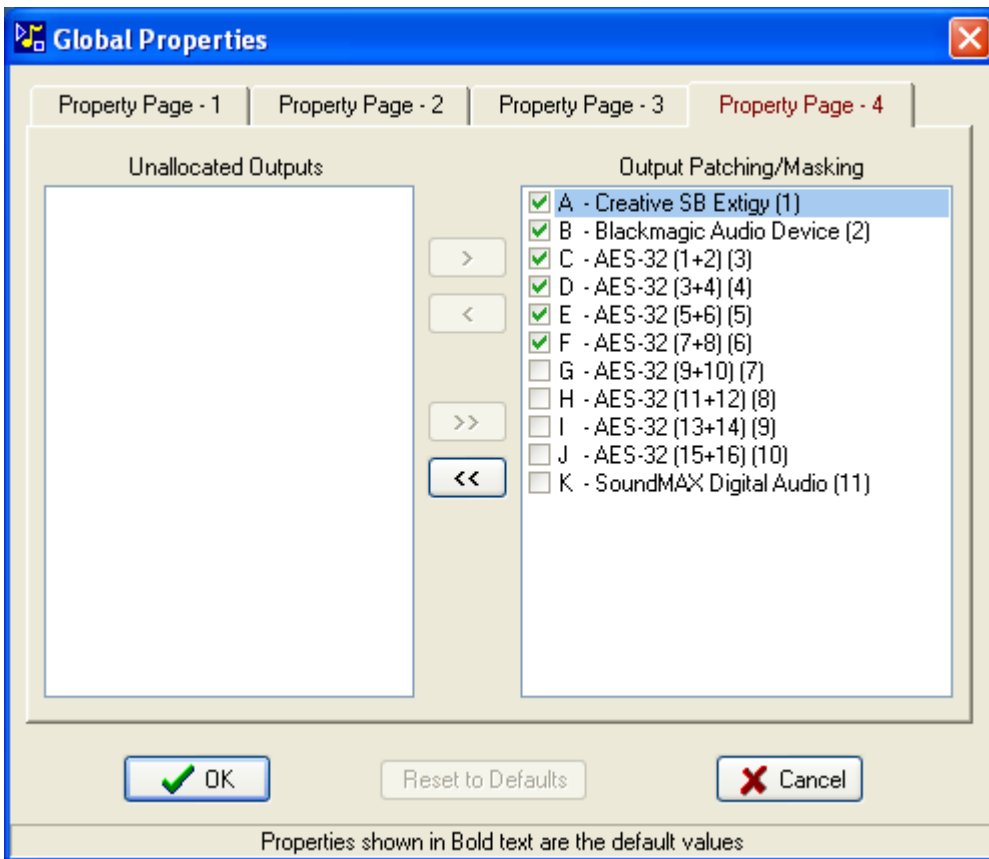

Clicking the << button will move all except the default output device into the left panel.

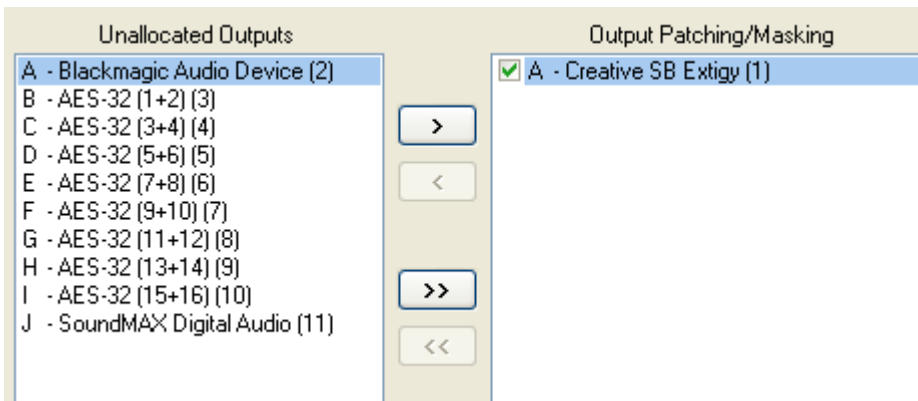

Now the output order can be built up by highlighting a entry in the left panel and clicking > to move the output in to the right hand panel.

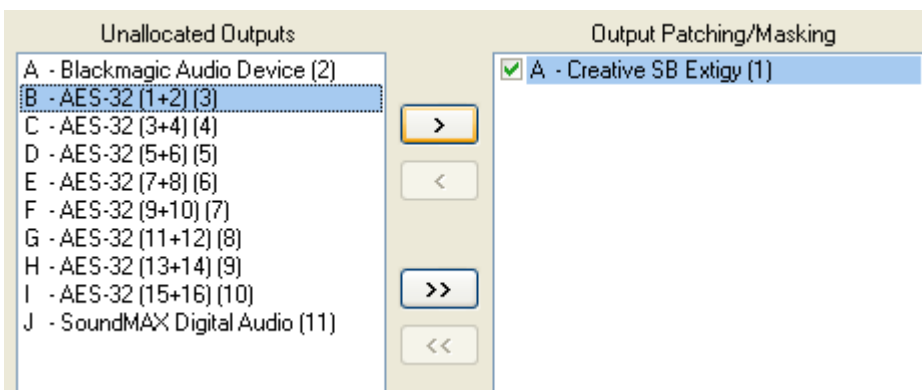

The moved entry will be automatically 'unmasked' (checkbox ticked)

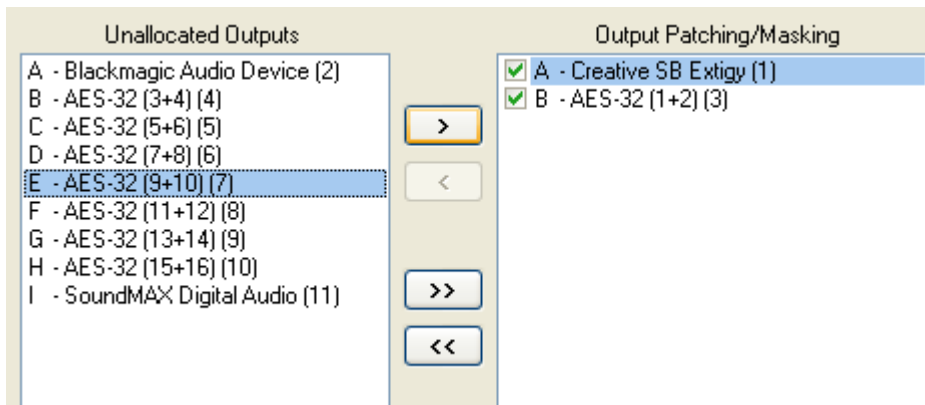

Continue moving entries until all the required outputs are in the right hand panel

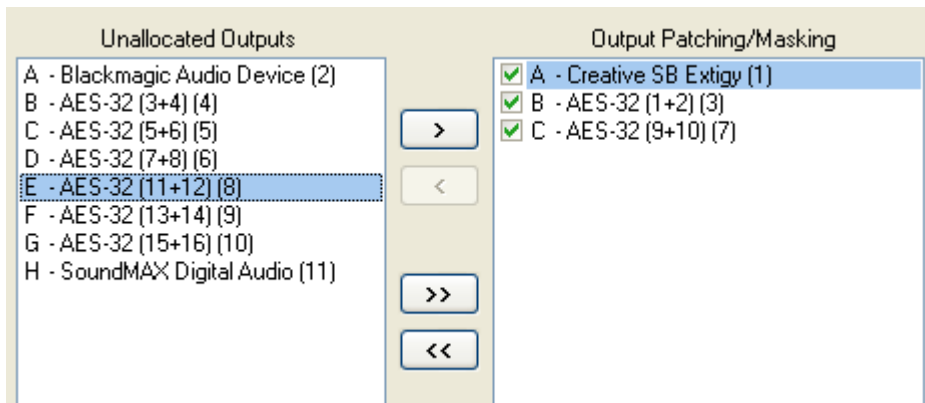

Finally move all the remaining entries across to the right hand panel by clicking >>

These items will be entered as masked.

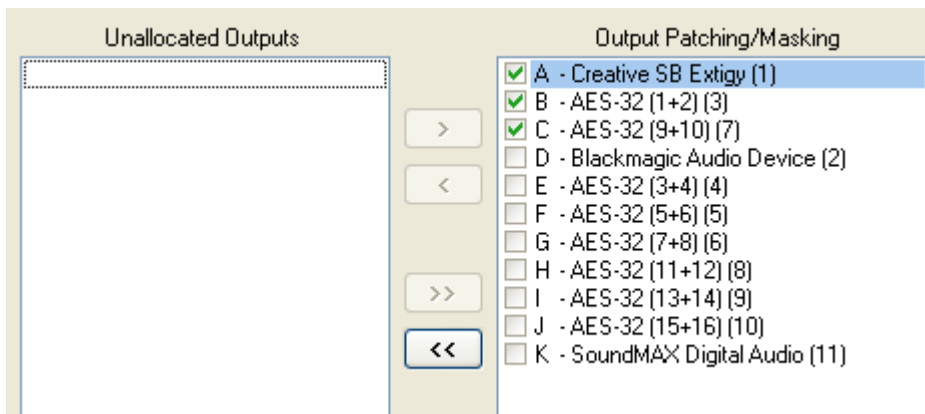

The order of the items in the right hand panel can be changed by left drag/dropping.

### **Try Remote Filename**

When loading a session file it is possible that some audio material referred to has been deleted from the local drive, in this case if the track assigned to a particular button cannot be found the button remains blank and a warning dialog will display the tracks not found.

However, if the Try Remote Filename option is checked then the original file location will also be tested to see if the file is still in that location, if it is it will be copied to the local drive. The disadvantage of this is that if network drives are being used and are offline, the timeout can be quite long making the program unresponsive.

## PBus Settings

SetUp for PBus control see [PBus Control](#)

**PBus Setup**

Port Number

None  
 Com 1  
 Com 2  
 Com 3  
 Com 4  
 Com 5  
 Com 6  
 Com 7  
 Com 8  
 Com 9  
 Com 10  
 Com 11  
 Com 12  
 Com 13  
 Com 14  
 Com 15  
 Com 16

Baud Rate

9600    19200    38400

Stop Bits

1  
 2

Parity

None    Odd    Even

Address Range 10..11 - Buttons 1..200

Base Address    Number of Addresses

Registers 0..99 at Addr 10 refer to Btns 1..100  
Registers 0..99 at Addr 11 refer to Btns 101..200  
Registers 0..99 at Addr 12 refer to Btns 201..300  
Registers 0..31 at Addr 13 refer to Btns 301..320

 

## Int/Ext Timecode

SpotOn can decode external SMPTE longitudinal timecode from a selected audio input or take the elapsed time timecode of a nominated button and use it to trigger [GPIs](#) or cause [AutoPlay](#) buttons to chase the timecode.

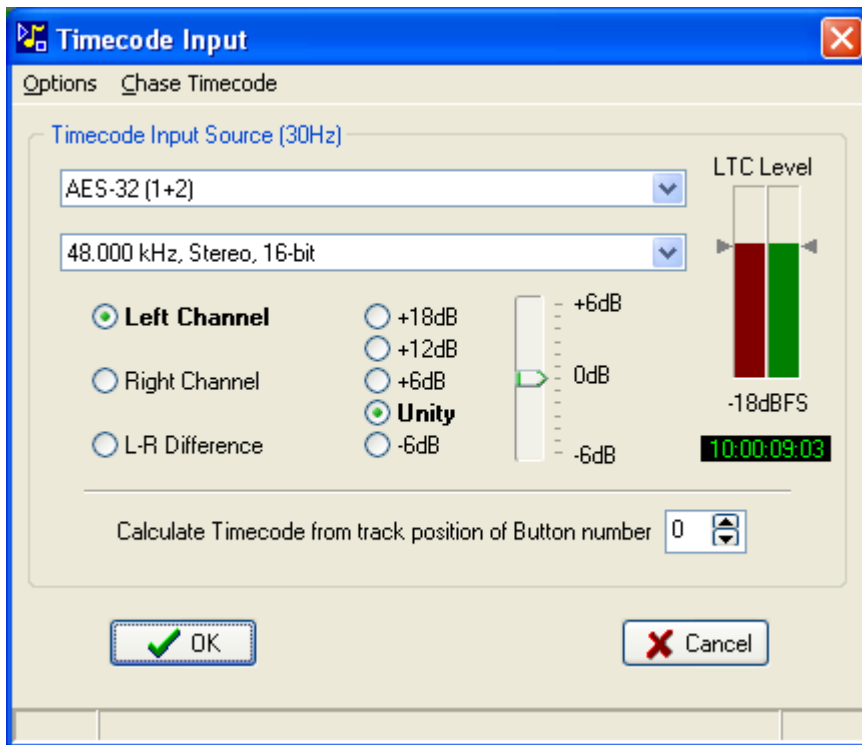

The analogue audio timecode (LTC) should be connected to an audio input channel and the channel selected from the upper drop-down menu.

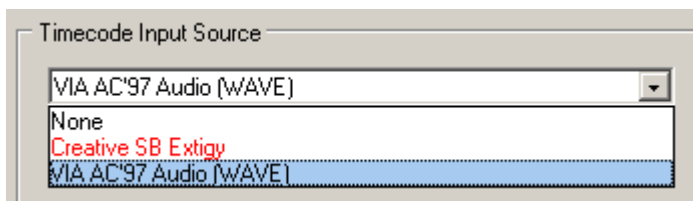

The lower drop-down menu selects the sample rate and bit depth for the timecode signal - this is fixed at 44.1kHz and 16 bit.



The bargraphs on the right hand side of the window show the signal levels for left and right channels, immediately below is the calculated average signal level and the decoded timecode value.

The timecode can be decoded from the Left or Right channels or the difference between the two channels, the last option is a facility to use a balanced feed of LTC with an unbalanced stereo input as might be found on a Laptop computer.

Coarse and fine gain adjustment are available to compensate for low level inputs, if possible the level should be set to match the markers (-18dBFS) on the level bars .

The default options are shown in bold text.

To use the alternative of deriving the timecode from a button select a non zero value in the button number box

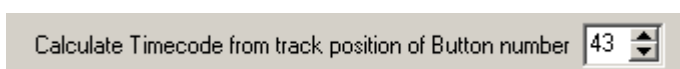

The action of selecting a non-zero button number will set the audio input to None, similarly setting the audio input selection to anything other than None will set the button number to zero.

The timecode is calculated from the current absolute position within the track and does not take into account any In Point that may be set.

If the button number is set to 321 (which exceeds the highest button number available) the timecode will be based on the PC internal clock.

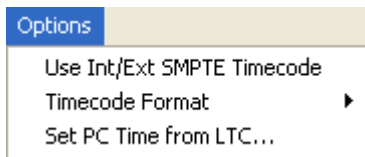

The Use Int/Ext SMPTE Timecode item duplicates the item in the [Options menu](#) and can disable/enable all the timecode facilities, if disabled a message will be shown in the lower part of the dialog.

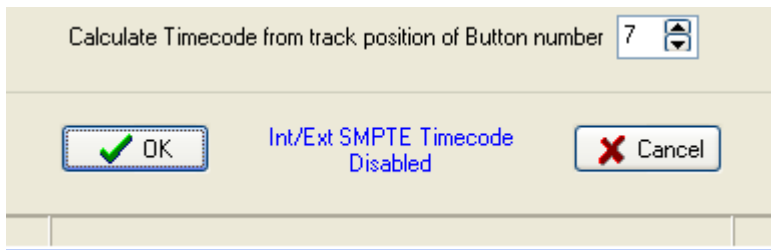

Timecode format to be changed from the default of 25Hz non-drop frame.



Additionally the external LTC signal can be used to set the PC clock, a prompt dialog box is shown with the current error

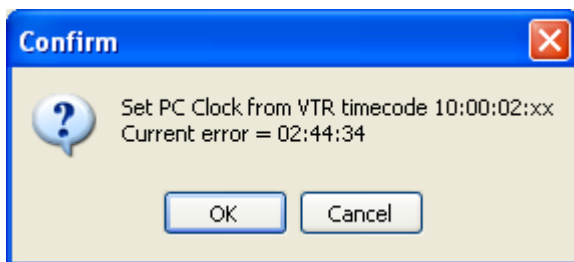

Access rights of the current user may restrict the ability to change the PC clock settings.

The timecode chase function allows [AutoPlay](#) buttons to chase external timecode, this function is enabled by checking 'Chase to Timecode On', alternatively this option can be set via a command line switch [/ChaseTCode](#).

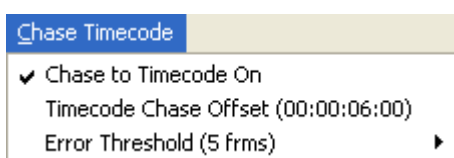

The buttons selected to chase timecode should preferably be BWAV files containing an embedded start timecode in the metadata. The start time on Non BWAV buttons or BWAV buttons with no embedded start time will default to a 00:00:00:00.

It is important that the global [Timecode Format](#) set above matches the external timecode being used, differences in frame rate are not flagged but if there is a discrepancy between drop frame and non-drop frame timecode it will be indicated in the right hand side of the status bar.

In the example below the global Timecode Format is set to 30Hz drop frame (29.97Hz), however the external timecode has been detected as non-drop frame.

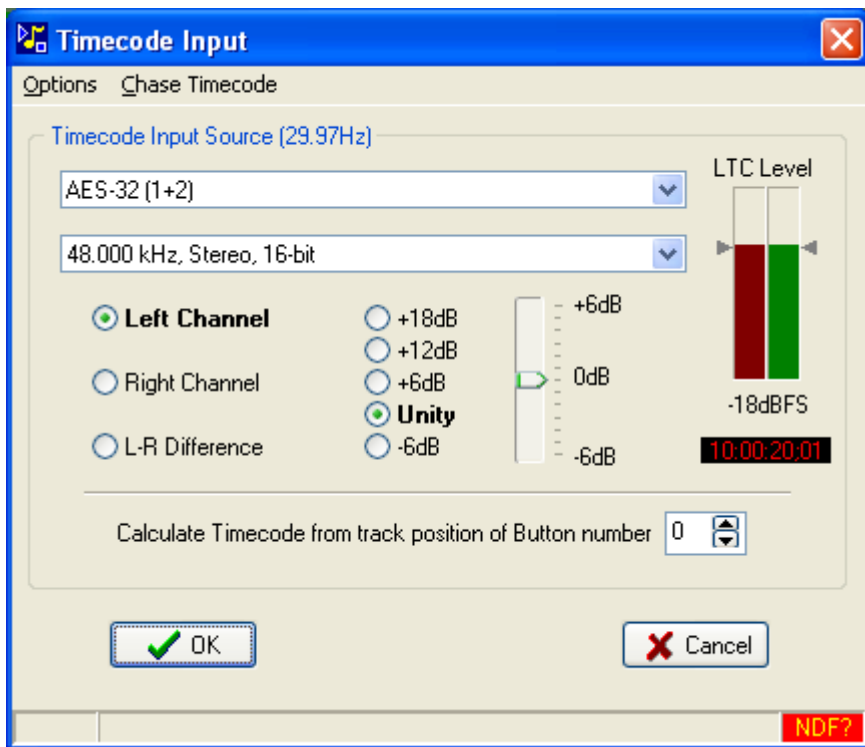

The dialog below enables an offset to be entered so that the button timecode is always a predetermined amount ahead of the external timecode.

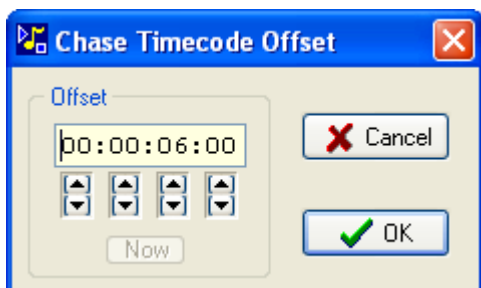

The Error Threshold setting defines how much error there has to be between the external timecode and the button timecode before the button is resynchronised.

- +/- 1 frame
- +/- 2 frames
- +/- 3 frames
- +/- 4 frames
- +/- 5 frames

## Timecode Triggers

The [Timecode Trigger List](#) offers a method of triggering buttons from incoming timecode as an alternative to emulated GPIs

## DTMF Tone Trigger

SpotOn can decode [DTMF](#) tone sequences and trigger buttons via associated Midi notes 16/100..115

## Network Target

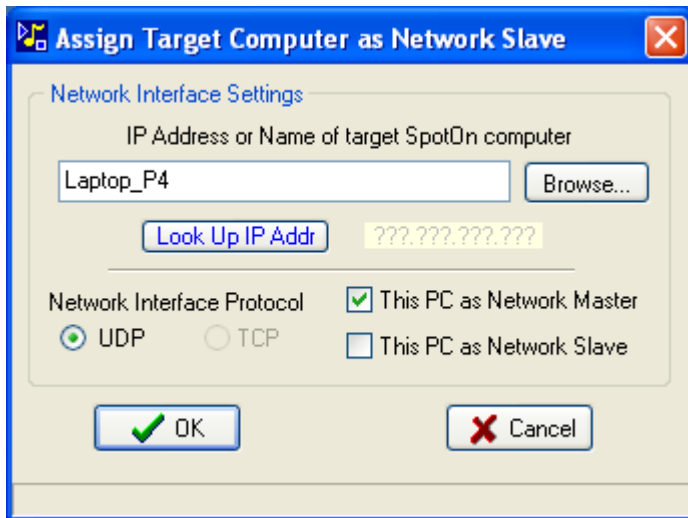

If a Target follow Master setup is required where two SpotOn computers have identical packages loaded and one computer is to track the other then 'This PC as Network Master' should be checked on the Master computer and 'This PC as Network Slave' checked on the Target computer.

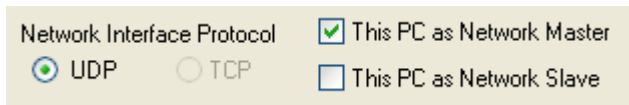

When loading packages onto other computers, the computer name and dongle number are automatically checked against those embedded in the package file to ensure the Networked messages are not looped back to the same computer.

On the status bar of the Master computer the MidiOut panel should have underlined text indicating it is a Network Master

Midi Out On

On the Master computer enter the computer name or IP address for the Target computer.

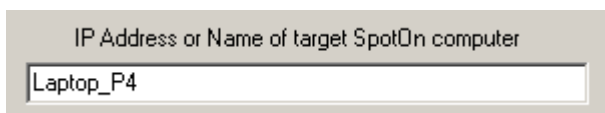

If only the computer name of the target computer is known, the current IP address of that computer can be found by clicking on LookUp IP Addr.

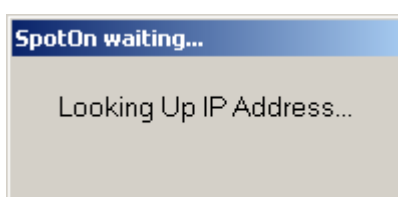

if the look up is successful then the IP address will be displayed proving that the computer is or was recently connected to the network

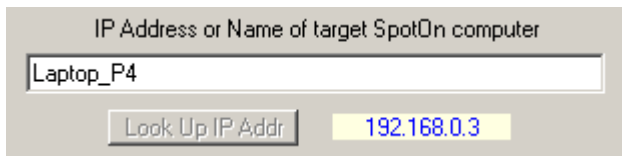

if the look up fails then Not Found is shown indicating that no computer of that name is currently on the network

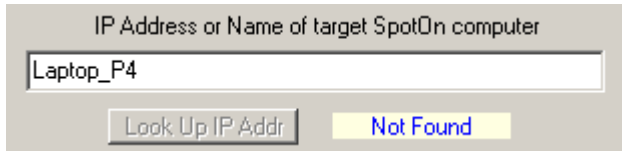

SpotOn will accept either the Target computer name or its IP address, entering the computer name is preferred on networks operating DHCP where the computer IP addresses are not fixed.

Other than loading the packages the following should be set automatically on exiting the dialog

On the Master computer "[Use Midi Out](#)" in the Options menu must be enabled.

On the target computer "[Use Midi In over Network|Midi In over UDP](#)" in the Engineering menu and "[Use Midi In](#)" in the Options menu must be enabled.

#### Master Computer

Network Master - checked  
Enter name of Target Computer  
Use Midi Out - enabled  
Load package

#### Target Computer

Network Master - unchecked  
Use Midi In over Network (UDP) - checked  
Use Midi In - enabled  
Load same package as Master

### **Midi In over Network**

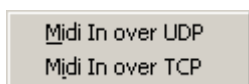

SpotOn can accept conventional Midi messages supplied via the sound card or game port, it can also respond to Midi messages passed to the computer running SpotOn via a network connection and is enabled by checking the UDP and/or TCP options.

The Midi In On mimic on the main window status bar will be in italics if either option is checked.

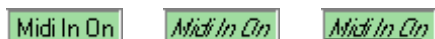

See [UDP/TCP Commands](#) for further information and details of non-Midi commands that can be sent over UDP

## Playout Logs

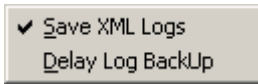

### [Save XML Logs](#)

Generate XML formatted playout logs as well as plain text logs

### Delay Log BackUp

Delays backup of Playout logs until all tracks are stopped, this

When Delayed Log BackUp is selected the Playout log display window title bar indicates the selection.

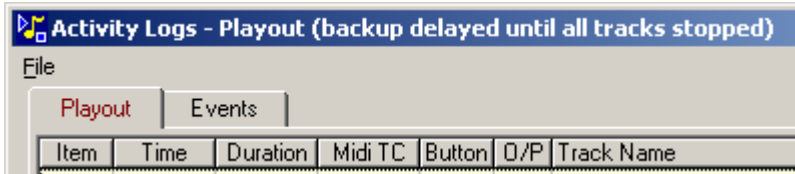

## Lock Session Files

To avoid accidental deletion or modification of files loaded into a session they can be set to be Read-Only for the duration of the session by using this option which is saved within the session and package files.

## Disable User Menus

If the SpotOn is to be used purely for playout and no loading or editing facilities are required then this option will disable all the main menus and the right click options.

## OSC over UDP

Allow SpotOn to respond to [OSC](#) (Open Sound Control) messages sent over UDP - Midi In over Network (UDP) and Midi In On options should also be selected.

## Plain Text over UDP

Enable response to [plain text](#) commands over UDP- Midi In over Network (UDP) and Midi In On options should also be selected.

## Misc

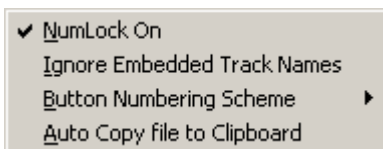

### NumLock On

Set NumLock on at start up

### [Ignore Embedded Track Names](#)

Ignore embedded track names when loading audio files

### [Button Numbering Scheme](#)

Arrange the numbering of tracks

### Auto Copy file to Clipboard

When checked the [button popup menu](#) Copy action will also copy

## Misc - NumLock On

When checked set the keyboard NumLock state to be On at start up

## Misc - Ignore Embedded Track Names

Audio files can have a 'Display name' embedded in the file along with the audio data, by default SpotOn uses this name if it is present as the Trackname when loading the file.

When this option is checked SpotOn will ignore the embedded 'Display Title' and make up a Trackname from the filename of the audio track when the file is initially loaded

## Misc - Button Numbering Scheme

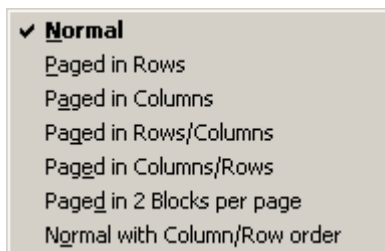

In some instances the default numbering of the buttons on the pages may not be suitable so a range of alternative schemes is available:-

Normal (numbers increase on subsequent pages)	1	2	3	4	5	6
	7	8	9	10	11	12
	13	14	15	16	17	18
	19	20	21	22	23	24
Paged in Rows (numbers the same on all pages)	1	2	3	4	5	6
	1	2	3	4	5	6
	1	2	3	4	5	6
	1	2	3	4	5	6
Paged in Columns (numbers the same on all pages)	1	1	1	1	1	1
	2	2	2	2	2	2
	3	3	3	3	3	3
	4	4	4	4	4	4
Paged in Rows/Columns (numbers the same on all pages)	1	2	3	4	5	6
	7	8	9	10	11	12
	13	14	15	16	17	18
	19	20	21	22	23	24
Paged in Columns/Rows (numbers the same on all pages)	1	5	9	13	17	21
	2	6	10	14	18	22
	3	7	11	15	19	23
	4	8	12	16	20	24
Paged in 2 Blocks per page (numbers the same on all pages)	1	5	9	1	5	9
	2	6	10	2	6	10
	3	7	11	3	7	11
	4	8	12	4	8	12

Normal but with Column/Row order	1	5	9	13	17	21
(numbers increase on subsequent pages)	2	6	10	14	18	22
	3	7	11	15	19	23
	4	8	12	16	20	24

## Clear Recent Lists

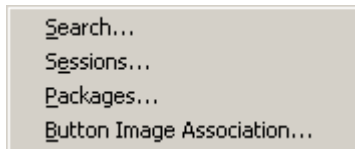

Recent history lists available from the File menu and the File Search history can be cleared with this option along with the button image associations, note Undo does not operate with these actions.

## Sample Frequency Limit

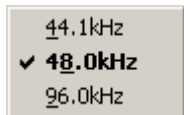

The sample frequency of WAV files can be any value - typically 8,000.. 96,000 samples/second, at the higher sample frequencies and especially with 32 bit samples the data rate can become very high and the application will slow down as more CPU time is absorbed during playback.

The default value is 48kHz which should be sufficient for most purposes.

## Volume Controls - menu item disabled

Each audio output device on a PC has its own set of mixer controls these can be accessed with this menu option

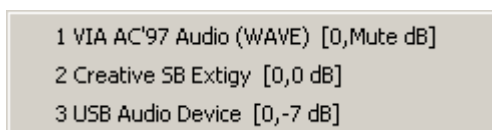

Note the level settings displayed to the right of the sound device name, these are of the form:-

[ Master level, Wave output level ]

Levels are shown in dB (0dB is the maximum level), if a level is muted the word "Mute" is shown instead of the level value.

Typical control panels are shown below - note that not all sound card drivers support all options.

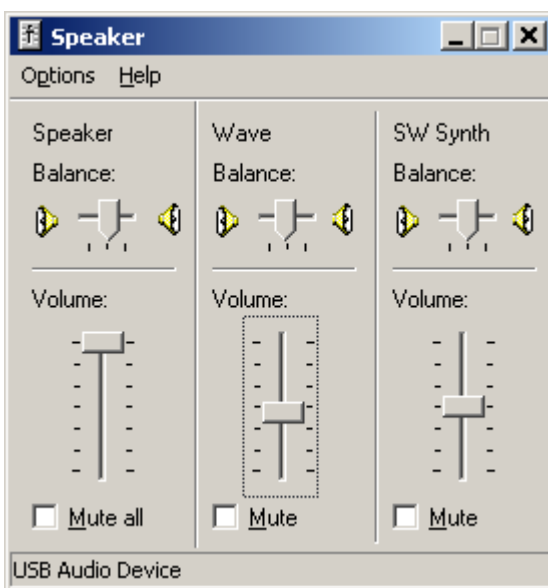
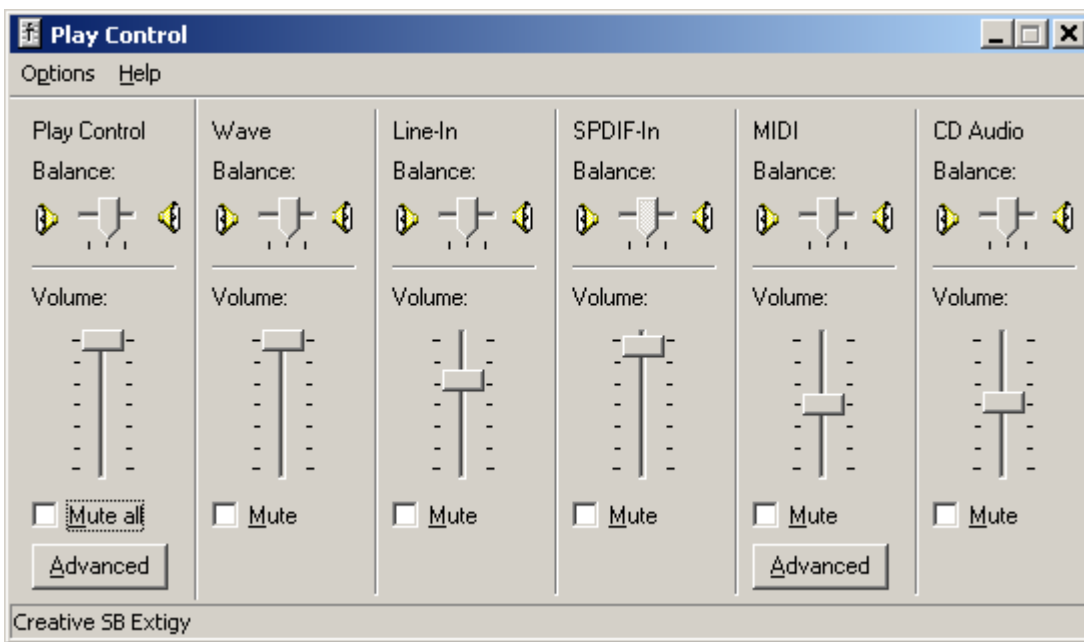
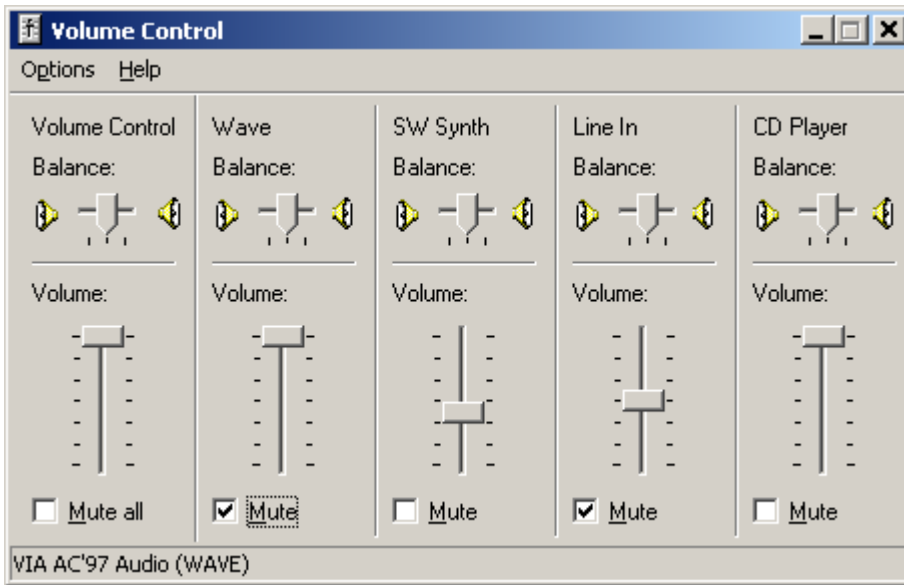

# DTMF Decoder

SpotOn can decode external DTMF tones (0..F) from a selected audio input and use them to trigger buttons via Midi notes 100..115 on channel 16.

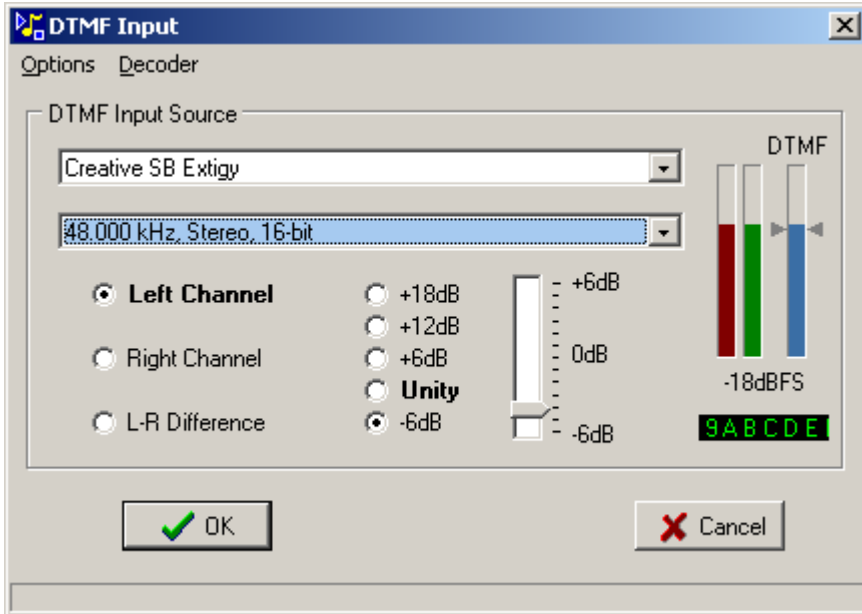

The analogue DTMF source should be connected to an audio input channel and the channel selected from the upper drop-down menu. If the source entry is displayed in red text then it is already in use as an input for the [SMPTE timecode](#) reader and is not available.

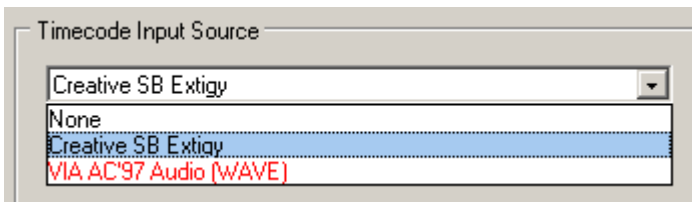

The lower drop-down menu selects the sample rate and bit depth for the timecode signal - this is fixed at 48kHz and 16 bit.



The bargraphs on the right hand side of the window show the signal levels for left, right and filtered channels, immediately below is the decoded data scrolling right to left.

Coarse and fine gain adjustment are available to compensate for low level inputs, if possible the level should be set so that the right hand bargraph matches the markers (-18dBFS).

The DTMF can be decoded from the Left channel, Right channel or the difference between the two channels, the last option is a facility to use a balanced feed of DTMF with an unbalanced stereo input as might be found on a Laptop computer.

The default options are shown in bold text.

The DTMF tones decoded are translated to Midi Note On messages in the range 100..115 on channel 16 for DTMF tones 0..F respectively where E=\* and F=#.

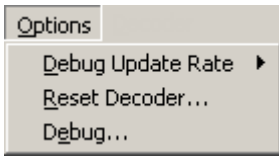

Debug Update rate sets the refresh period of the debug display



Reset Decoder sets all the decoder parameters to their default values after clicking on OK in the confirmation dialog

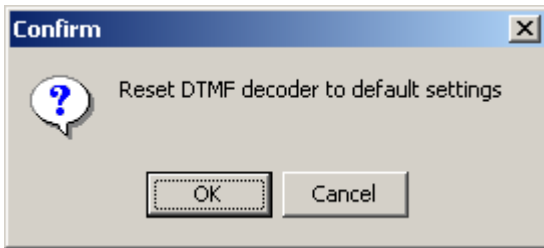

The Debug option displays a live timestamped list of the incoming DTMF data along with analysis of the signal quality

	0	1	2	3	4	5	6	7	Error	Twist	Tone3	Rat
	697Hz	770Hz	852Hz	941Hz	1209Hz	1336Hz	1477Hz	1633Hz		dB	dB	%
0000mS >	92,	176,	2304,	123,	1040,	25,	46,	25	tone3	-6.9	-15.4	8
0025mS >	28,	39,	4,	7,	7,	25,	3,	5	bntot	2.9	-1.0	5
0050mS >	42,	12,	15,	18,	4,	30,	7,	8	bntot	-2.9	-4.6	5
0075mS >	32,	26,	47,	383,	12,	311,	10,	6	tone3	-1.8	-16.4	8
0100mS >	49,	144,	101,	2138,	37,	2326,	26,	6 = 0		0.7	-23.5	9
0125mS >	42,	223,	95,	1454,	46,	2169,	26,	9	tone3	3.5	-16.3	8
0150mS >	46,	178,	16,	36,	9,	134,	7,	4	bntot	-2.5	-9.3	7
0175mS >	32,	117,	18,	7,	6,	14,	9,	2	bntot	11.2	-5.3	7
0200mS >	47,	39,	9,	4,	14,	40,	12,	4	bntot	-1.3	-0.4	5
0225mS >	696,	100,	17,	19,	434,	78,	15,	13	tone3	-4.1	-12.8	8
0250mS >	2634,	123,	17,	16,	1708,	70,	14,	13 = 1		-3.8	-22.9	9
0275mS >	1246,	104,	11,	8,	1181,	43,	11,	9 = 1 ****		-0.5	-21.1	9
0300mS >	18,	38,	10,	2,	59,	15,	5,	4	bntot	3.8	-6.6	6
0325mS >	13,	63,	16,	6,	2,	9,	4,	1	bntot	-11.9	-1.7	6
0350mS >	35,	53,	8,	2,	4,	15,	7,	3	bntot	3.7	-7.6	6
0375mS >	1301,	50,	20,	10,	6,	18,	934,	13 = 3		-2.9	-25.4	9
0400mS >	2493,	91,	53,	18,	10,	41,	2766,	33 = 3 ****		0.9	-28.8	9
0425mS >	802,	55,	32,	11,	6,	39,	1334,	20 = 3		4.4	-23.2	9
0450mS >	26,	57,	25,	2,	3,	32,	58,	3	bntot	0.0	-5.0	5
0475mS >	19,	51,	54,	2,	2,	20,	11,	4	bntot	0.5	-8.2	6
0500mS >	33,	88,	21,	4,	33,	13,	8,	4	bntot	8.6	0.0	5
0525mS >	43,	1911,	21,	10,	998,	17,	5,	12 = 4		-5.6	-27.2	9
0550mS >	71,	2899,	10,	6,	1749,	30,	11,	10 = 4 ****		-4.4	-27.9	9
0575mS >	44,	286,	29,	9,	447,	22,	4,	4	tone3	3.9	-16.3	8
0600mS >	30,	5,	27,	4,	17,	4,	1,	1	bntot	-1.1	-4.0	6
0625mS >	12,	5,	57,	4,	3,	4,	2,	2	bntot	13.7	-7.8	7
0650mS >	41,	195,	77,	9,	99,	9,	13,	5	bntot	-5.9	-2.2	6
0675mS >	106,	2725,	58,	30,	1235,	59,	24,	21 = 4		-6.9	-21.4	9
0700mS >	156,	2237,	329,	42,	1787,	45,	14,	6	tone3	-2.0	-14.7	8
0725mS >	162,	133,	68,	13,	224,	11,	10,	3	tone3	2.8	-1.7	6
0750mS >	156,	23,	32,	6,	11,	2,	3,	1	bntot	-13.8	-2.7	8
0775mS >	169,	58,	64,	14,	7,	7,	6,	4	bntot	-8.5	-0.8	7
0800mS >	149,	372,	1165,	73,	16,	340,	11,	6	hilo	9.9	-0.8	7
0825mS >	232,	43,	2573,	70,	24,	1934,	29,	11	2ndt2	-2.5	-18.4	9
0850mS >	87,	45,	1384,	69,	35,	1858,	41,	36 = 8		2.6	-24.0	9
0875mS >	54,	32,	191,	22,	27,	90,	50,	118	tone3	-4.2	-2.3	5
0900mS >	19,	33,	67,	48,	8,	12,	31,	167	bntot	7.9	-2.9	6
0925mS >	50,	29,	102,	68,	47,	6,	27,	89	bntot	-1.2	-2.3	4
0950mS >	138,	37,	450,	62,	297,	22,	61,	13	tone3	-3.6	-6.7	6
0975mS >	65,	59,	3611,	175,	1619,	80,	36,	32	2ndt1	-7.0	-19.3	9

Portion of DFT bins sum in DTMF Tone 1 = 25%

Minimum DFT bins sum = 500

Maximum value of 2nd harmonic of Tones 1+2 = -30dB\*

Hold

DTMF tone twist limit = -12/+9dB\*

Maximum value of adjacent bin wrt Tone 2 = -18dB\*

Signal pre-filter = Wideband +/-0.50dB\*

The labels at the bottom of the screen show the decoder parameters, those with a '\*' suffix have right-click popup menus enabling the parameters can be changed live.

The Hold button at the bottom centre freezes the display for analysis, the Spacebar is the shortcut key for this button.

The Debug window is split into columns

Timestamp	25mS block decoding		
Tone Levels	Levels of the individual DTMF tones received		
Decoded Value	Decoded character 0..9, A..F		
Error	****	No Error	
	bntot	Total of all the frequency components not above threshold - insufficient signal	
	tone1	Ratio of the level of tone 1 to the sum of all frequency components not above	
	revtw	Higher tone level is greater than lower tone level and exceeds limit - channel has	
	nortw	Higher tone level is less than lower tone level and exceeds limit - channel has an	
	tone3	Next largest tone after the two main tones is not suppressed sufficiently -	
	hilo	Two tones detected are either both Lo tones or both Hi tones - there should be	
	2ndt1	Second harmonic of main tone 1 is larger than expected, so may not be a DTMF	
2ndt2	Second harmonic of main tone 2 is larger than expected, so may not be a DTMF		
Twist	Measure of the relative values of the two main tones, shown as Normal Twist (nortw)		
Tone3	Level of Tone 3 when compared with Tone 2 exceeds the preset limit		
Ratio	Ratio of levels of Tone 1+Tone 2 to overall total is insufficient		

	0	1	2	3	4	5	6	7	Error	Twist	Tone3	Ratio
	697Hz	770Hz	852Hz	941Hz	1209Hz	1336Hz	1477Hz	1633Hz		dB	dB	%
0875mS >	54,	32,	191,	22,	27,	90,	50,	118	tone3	-4.2	-2.3	53
0900mS >	19,	33,	67,	48,	8,	12,	31,	167	bntot	7.9	-2.9	61
0925mS >	50,	29,	102,	68,	47,	6,	27,	89	bntot	-1.2	-2.3	46
0950mS >	138,	37,	450,	62,	297,	22,	61,	13	tone3	-3.6	-6.7	69
0975mS >	65,	59,	3611,	175,	1619,	80,	36,	32	2ndt1	-7.0	-19.3	92

At timestamp 875mS the two tones detected correspond to DTMF frequencies 2 (tone 1 - highest level) and 7 (tone 2 - second highest level) and are shown in blue text.

The error is 'tone3' because the next largest signal shown in green text at DTMF frequency 5 (tone 3) is too close in level to DTMF frequency 7 (tone 2), the difference is -2.3dB, the relative level of tone 3 is shown in magenta coloured text as it exceeds the tone 3 limit of -18dB.

At timestamp 975mS the two tones detected correspond to DTMF frequencies 2 (tone 1) and 4 (tone 2), tone 2 is shown as normal in blue text but tone 1 is shown in magenta text which corresponds to the error '2ndt1' indicating the second harmonic of tone 1 exceeds the threshold.

The example below shows a high quality DTMF signal being decoded.

At timestamps 0, 25, & 50mS there is insufficient signal at the DTMF frequencies so the error is 'bntot', the next 3 entries correctly detect a '9', after two valid decodes the character is accepted as being good '\*\*\*\*'. A similar sequence of events follows when decoding the next character 'A'.

	0	1	2	3	4	5	6	7	Error	Twist	Tone3	Ratio
	697Hz	770Hz	852Hz	941Hz	1209Hz	1336Hz	1477Hz	1633Hz		dB	dB	%
0000mS >	15,	5,	6,	3,	7,	4,	31,	9	bntot	6.7	-3.9	58
0025mS >	17,	4,	2,	6,	4,	7,	10,	5	bntot	-4.1	-3.1	48
0050mS >	4,	6,	160,	14,	11,	5,	101,	4	bntot	-4.0	-17.2	85
0075mS >	3,	12,	332,	13,	5,	11,	329,	9 = 9		-0.1	-27.9	93
0100mS >	10,	9,	374,	9,	4,	10,	313,	7 = 9 ****		-1.5	-29.8	93
0125mS >	13,	7,	333,	17,	8,	6,	277,	8 = 9		-1.6	-24.4	91
0150mS >	12,	23,	38,	7,	4,	2,	54,	5	bntot	3.0	-4.3	63
0175mS >	50,	22,	13,	9,	6,	9,	14,	30	bntot	-4.5	-2.6	52
0200mS >	287,	13,	11,	11,	9,	4,	22,	166 = A		-4.8	-17.6	87
0225mS >	300,	11,	13,	18,	6,	3,	20,	260 = A ****		-1.3	-22.4	89
0250mS >	231,	18,	6,	9,	13,	2,	7,	297 = A		2.2	-22.2	90
0275mS >	107,	13,	13,	7,	4,	3,	13,	207	bntot	5.7	-18.1	86

The Decoder menu sets the individual parameters of the decoder

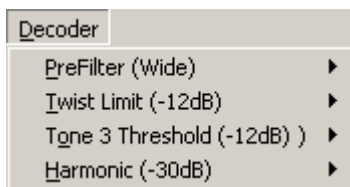

The narrowband PreFilter selects only the DTMF tone spectrum range whereas the wideband filter includes the second harmonics of the DTMF tones



Twist is a measure of the relative amplitudes of the two most significant tones (tone 1 and tone 2)

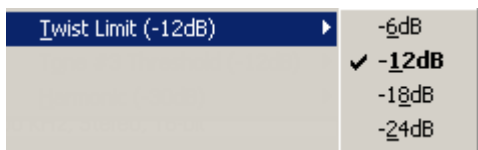

Tone 3 threshold sets the limit for the next largest frequency component after the two most significant tones

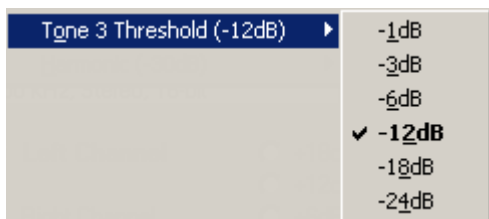

With the Wideband prefilter selected a further check on the validity of the DTMF tones can be made by testing the level of the second harmonic of the primary tones.

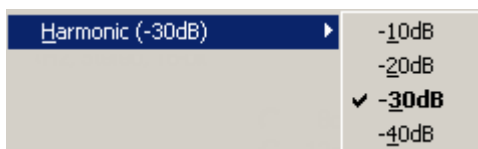

In the SpotOn\TestFiles folder are a selection of DTMF wav files:-

- |                         |   |
|-------------------------|---|
| DTMF?_48_A_M18.wav      | Single pulse of DTMF '0'.. DTMF 'F' at 48kHz 16 bit mono at -18dBFS                           |
| DTMF_48_TestToneSeq.wav | Sequence of DTMF characters at 48kHz 16 bit mono at -18dBFS                                   |
| DTMF_48_TestTones.wav   | Sequence of DTMF tones 0..7 and then all tones simultaneously at 48kHz 16 bit mono at -34dBFS |

The DTMF decoder is enabled via the [options menu](#) selection Use DTMF Tone Trigger

# Timecode Trigger List

The Timecode Triggers dialog offers a list of timecode trigger points allocated to buttons, the list is formed of 6 columns.

The first column is the entry number followed in the next column (#) showing the state of the trigger, the third column (On) shows if the entry is enabled, clicking in the cells in the 'On' column will toggle the enabled state, this state is mimicked on the right hand edit panel as 'Trigger On'. The next three columns show cue point timecode, button number and button name respectively.

Clicking on the column headers will sort the list.

#	On	Timecode	Btn	Name
1	✓	10:00:02:00	69	Untitled12
2	✓	10:00:05:00	65	white_noise
3		10:00:06:00	69	Untitled12
4		10:00:08:00	69	Untitled12
5		10:00:08:00	69	Untitled12
6				
7				
8				
9				
10				
11				
12				
13				
14				
15				
16				
17				
18				
19				
20				
21				

Button numbers can be entered by typing directly into the right hand Button Number section or by using the up/down nudge buttons. If the button selected is blank the number and the entry in the list will be shown in italic text as shown below in entry 6.

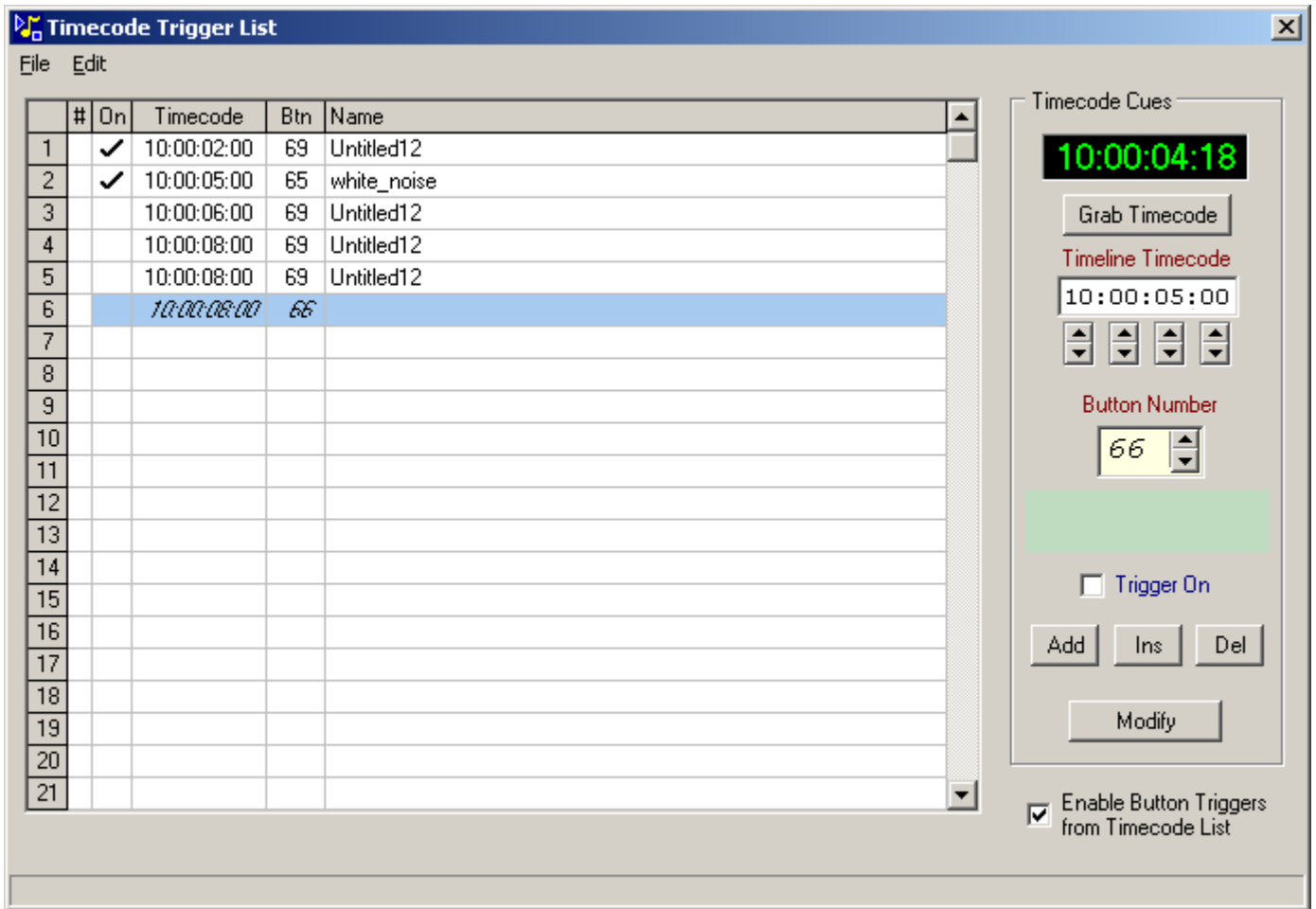

The timecode display in the upper right corner shows the [SMPTC timecode](#) being decoded from either an external source or directly from a button, the text will be yellow if no timecode is available.

The Mark Cue button will load the current timecode and add a new entry to the list, this can be used to make a first pass at setting the timecode cues.

The Add button will add a new entry to the end of the list, Del button will delete the selected entry and the Modify button will update the selected entry with the data in the right hand edit section.

The Insert button will insert a new entry above the selected line moving all higher numbered entries one line, if the list is full the last entry will be lost.

the State column show the current state of the cue - armed (green), playing (red) and elapsed (yellow).

#	On	Timecode	Btn	Name
1	✓	10:00:02:00	69	Untitled12
2	✓	10:00:05:00	65	white_noise
3		10:00:06:00	69	Untitled12
4		10:00:08:00	69	Untitled12
5		10:00:08:00	69	Untitled12
6		10:00:08:00	66	
7				

Cues 1 and 2 are armed.

#	On	Timecode	Btn	Name
1	✓	10:00:02:00	69	Untitled12
2	✓	10:00:05:00	65	white_noise
3		10:00:06:00	69	Untitled12
4		10:00:08:00	69	Untitled12
5		10:00:08:00	69	Untitled12
6		<i>10:00:08:00</i>	<i>66</i>	
7				

Cue 1 is playing and cue 2 armed.

#	On	Timecode	Btn	Name
1	✓	10:00:02:00	69	Untitled12
2	✓	10:00:05:00	65	white_noise
3		10:00:06:00	69	Untitled12
4		10:00:08:00	69	Untitled12
5		10:00:08:00	69	Untitled12
6		<i>10:00:08:00</i>	<i>66</i>	
7				

Cue 1 has elapsed and cue 2 armed.

Items in the list can be selected by single clicks or using the standard Shift+click for a block of items.

#	On	Timecode	Btn	Name
1		09:57:06:00	1	Sting 4 N
2		09:59:30:00	10	Round 2
3		09:59:30:00	7	Bed 5 main N95%
4		09:59:58:00	11	Round 3
5		09:59:58:00	18	vote bed
6		10:00:20:00	22	Sudden Death
7		10:00:36:22	34	HeadtoHead N

or Ctrl+click for a non-contiguous block of items.

#	On	Timecode	Btn	Name
1		09:57:06:00	1	Sting 4 N
2		09:59:30:00	10	Round 2
3		09:59:30:00	7	Bed 5 main N95%
4		09:59:58:00	11	Round 3
5		09:59:58:00	18	vote bed
6		10:00:20:00	22	Sudden Death
7		10:00:36:22	34	HeadtoHead N
8		10:00:36:22	20	Sting 4 N

There is a right-click popup menu on the list

Clear Entry
Copy
Paste
Insert
Clear List
Compact List

Clear Entry allows the selected entries to be deleted, Copy will temporarily copy the selected entries to the clipboard.

Paste will paste the entries from the clipboard over the list starting at the currently selected row, Insert will move the selected entry and all higher numbered entries toward the end of the list and insert the entries from the clipboard into the blank lines created.

Compact List removes any blank lines and sorts the list into timecode order and finally Clear List will delete all entries.

There are two main menu sections File and Edit.

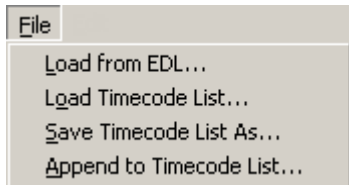

- |                         |   |
|-------------------------|---|
| Load from EDL           | Load timecodes from a section of an EDL file *.edl or *.txt |
| Load Timecode List      | Load timecodes from disc file *.tcl                         |
| Save Timecode List As   | Save timecode list to disc file *.tcl                       |
| Append to Timecode List | Load timecodes from disc and append to end of current list  |

Under the Edit menu are options to Undo or Redo changes

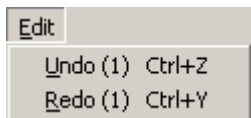

Timecode Triggers are enabled via the [Options menu](#), this option is copied by the Enable Button Triggers checkbox in the lower right of the window.

Loading timecodes from an EDL (Edit Decision List) - an EDL contains four columns of timecode along with transition instructions, a typical EDL is shown below

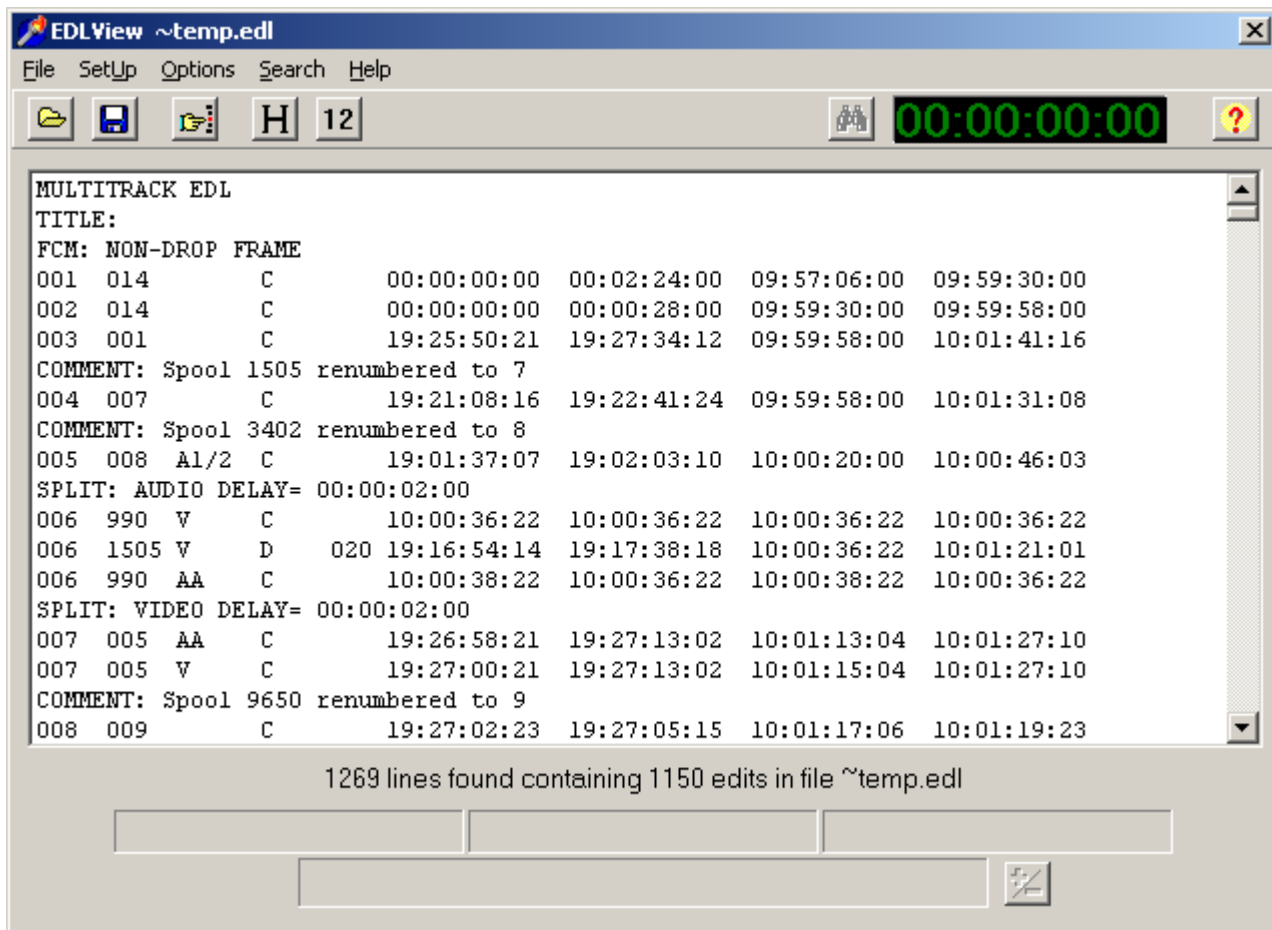

Using the Load from EDL option the timecodes can be extracted and displayed as a simple list, the section of timecodes to be added to the Timecode Trigger list are selected by left-click dragging across the text. Any partial lines selected will be included in the example below lines 10 to 20 inclusive will be transferred.

Only one timecode column can be used and that is selected from the options immediately below the listing, Recorder In is the default

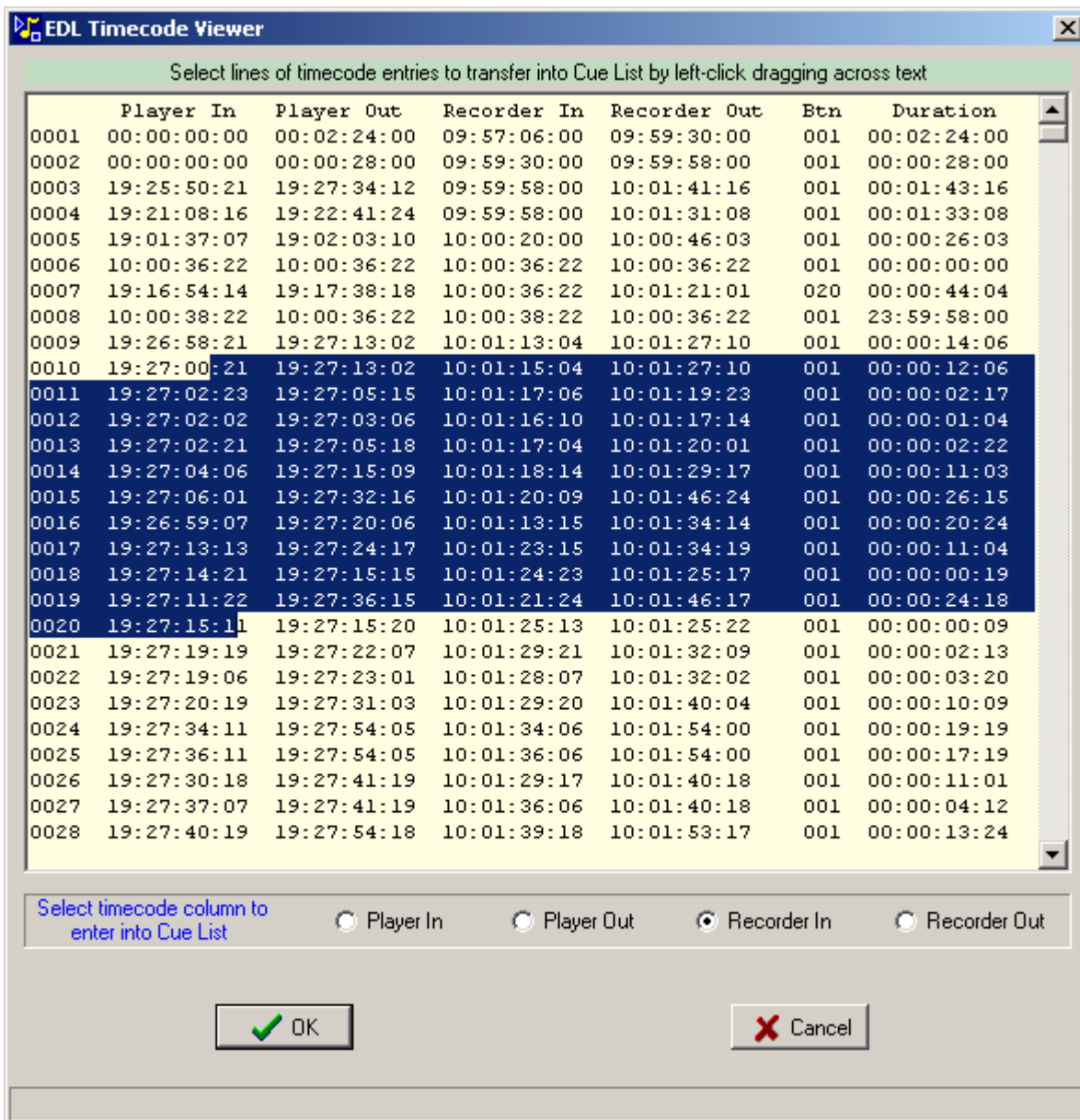

There is no option for button numbers to appear in the standard EDL so the Dissolve time is used to indicate the 3 digit button number, below the button number 020 will be associated with Player In timecode 19:16:54:14

```
006 990 V C 10:00:36:22 10:00:36:22 10:00:36:22 10:00:36:22
006 1505 V D 020 19:16:54:14 19:17:38:18 10:00:36:22 10:01:21:01
006 990 AA C 10:00:38:22 10:00:36:22 10:00:38:22 10:00:36:22
```

This can be seen in line 6 of the EDL Timecode Viewer above.

This interpretation of button numbers could be used if facilities to generate a dummy EDL is available, alternatively SpotOn can load simple text files based on the format:-

```
D 023 12:34:56:01
D 132 01:23:45:10
```

This could be produced directly in a text editor or extracted from a spreadsheet as a tab delimited file.

# Admin Menu

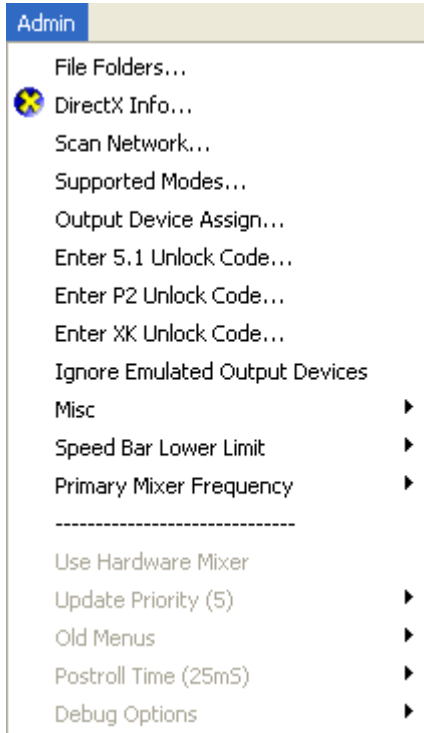

## [File Folders](#)

DirectX Info

[Scan Network](#)

[Supported Modes](#)

[Output Device Assign](#)

[Enter 5.1 Unlock Code](#)

[Enter P2 Unlock Code](#)

[Enter Xk Unlock Code](#)

[Ignore Emulated Output Devices](#)

[Misc](#)

[Speed Bar Lower Limit](#)

[Primary Mixer Frequency](#)

Sets folder locations for application data

Opens Microsoft DirectX diagnostic tool

Scan network for other SpotOn systems

Analyse modes supported by audio output devices

Configures audio output patching

Enable SpotOn for 5.1 surround sound operation

Enter unlock code to enable SpotOn\_P2

Enter unlock code to enable SpotOn\_Xk

Prevent SpotOn from opening Emulated Output Devices

Miscellaneous settings

Define the lower limit of the speed change slider bar

Sets the Windows sound mixer sampling frequency

## File Folders

File Folders option displays a selection dialog box to define the locations of the folders used for:-

- a, temporary storage when tracks are copied prior to being edited by an external WAV file editor
- b, storage for tracks loaded from a network connection or a CD
- c, root folder in which new folders are created for files extracted from packages
- d, folder for playout logs containing a timestamped listing tracks played
- e, location of session backup files which can be used to recover from a computer failure
- f, default location for User session files
- g, default folder for loading audio files

These settings are also displayed in the [Info|Status](#) listing

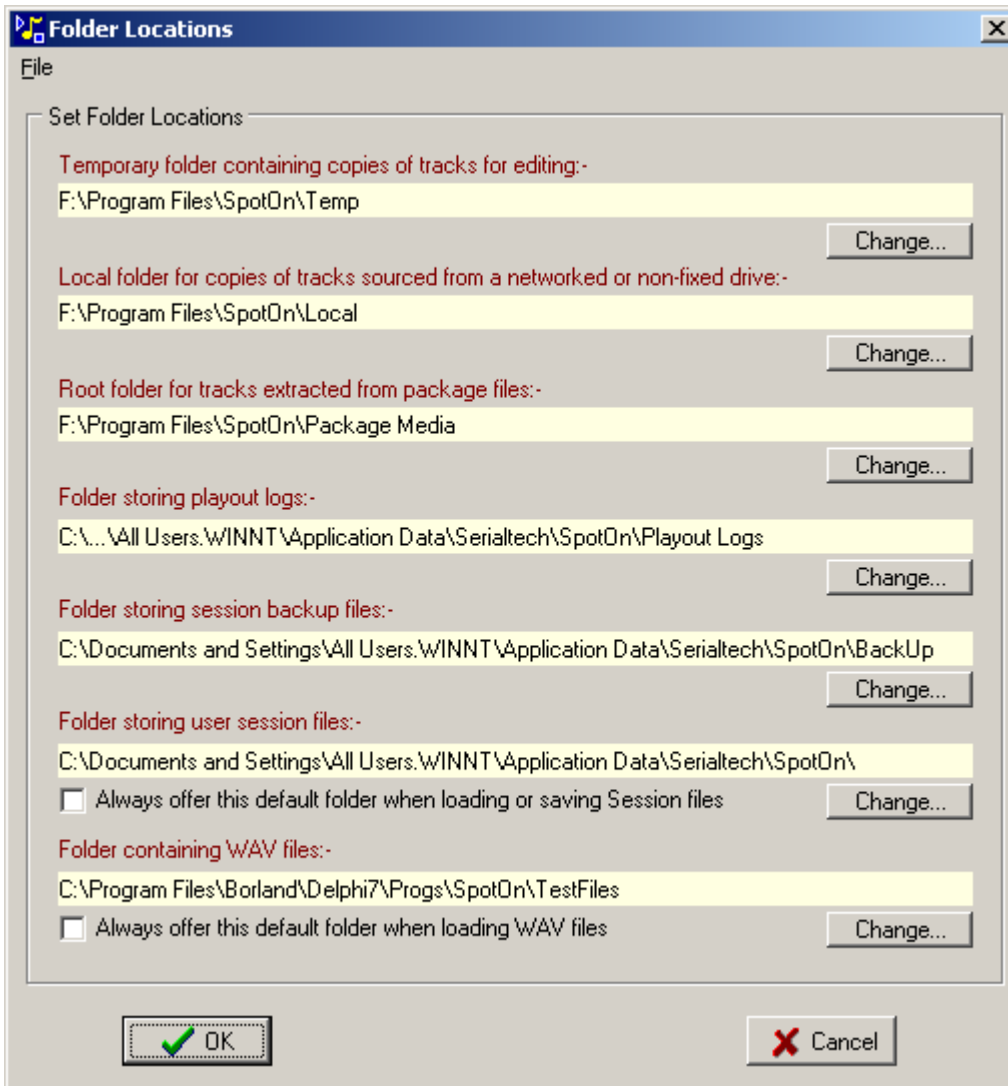

Clicking on the Change button will show a Folder Section dialog.

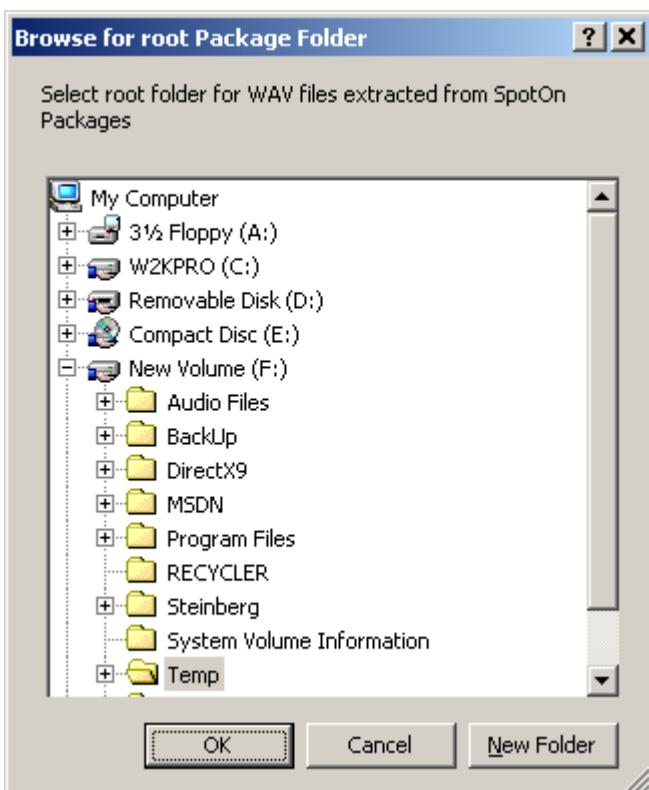

By default any files sourced from a network connection or a CD will be stored in the location defined in Folder Locations, however a dialog box will appear each time a remote file is loaded.

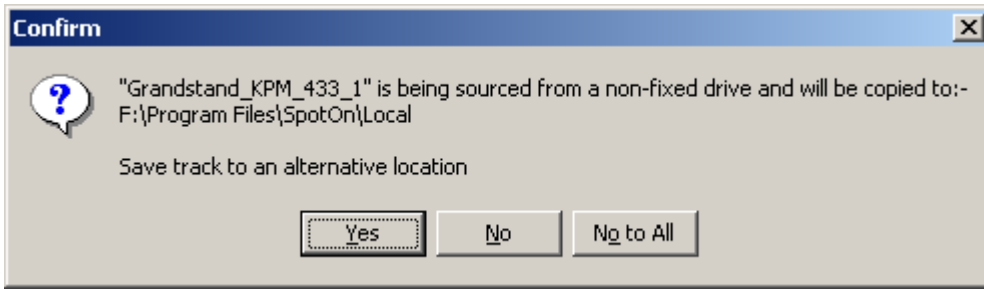

This gives the opportunity to save the file to a more appropriate - programme related - folder. If "Yes" is selected then a further folder selection dialog is shown.

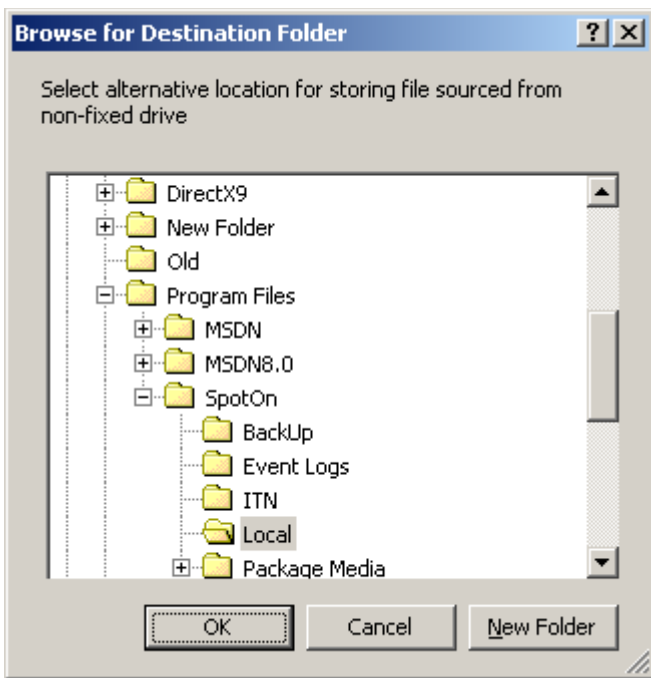

## Scan Network

In order to administer a network containing several SpotOn installations, it is useful to be able to scan through all of the installations currently running and list the version number along with other system parameters.

The window below shows the result of running the scan on a small network with two installations



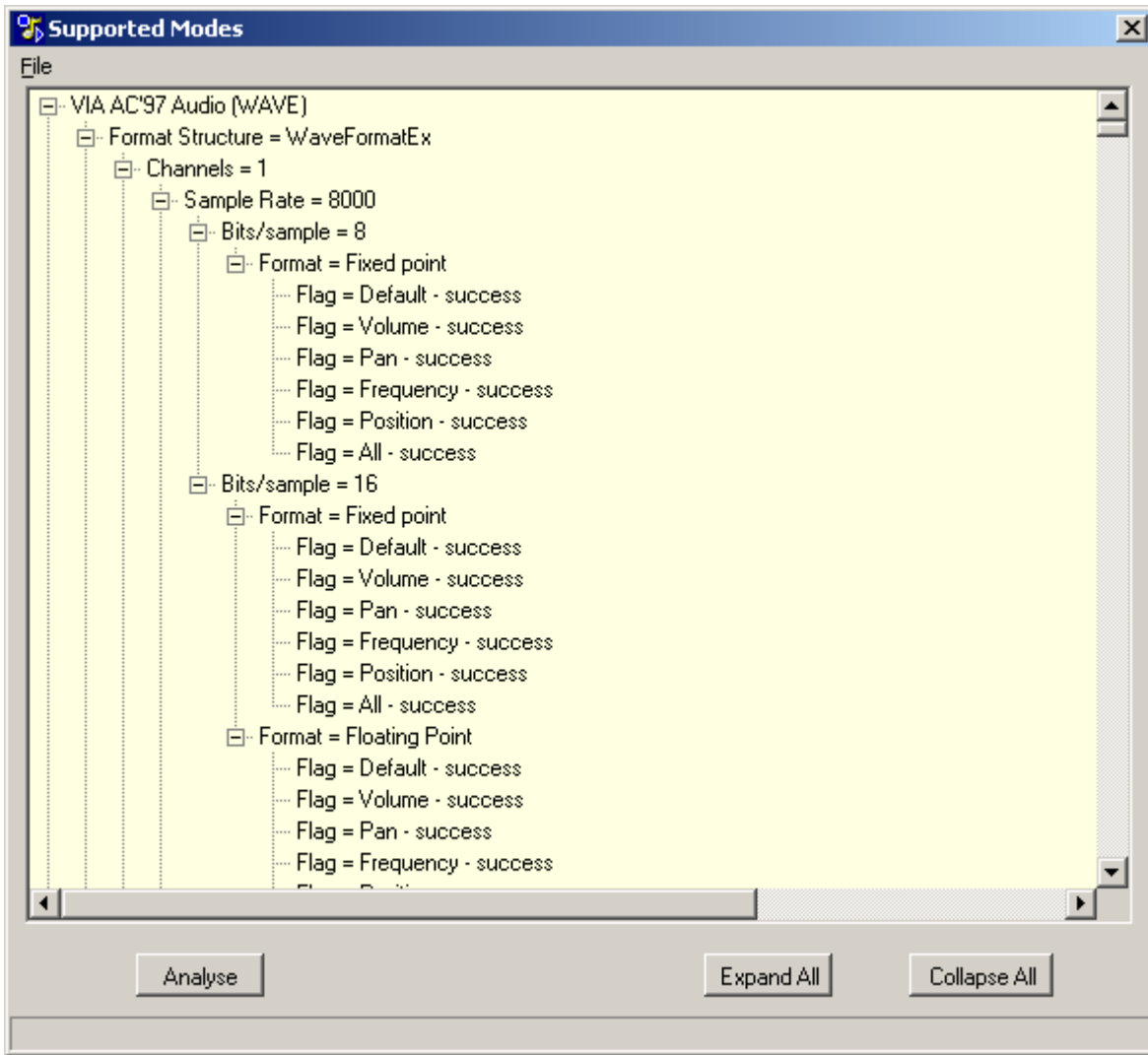

The results can be saved to a text file via the File|Save As menu option.

## Output Device Assign

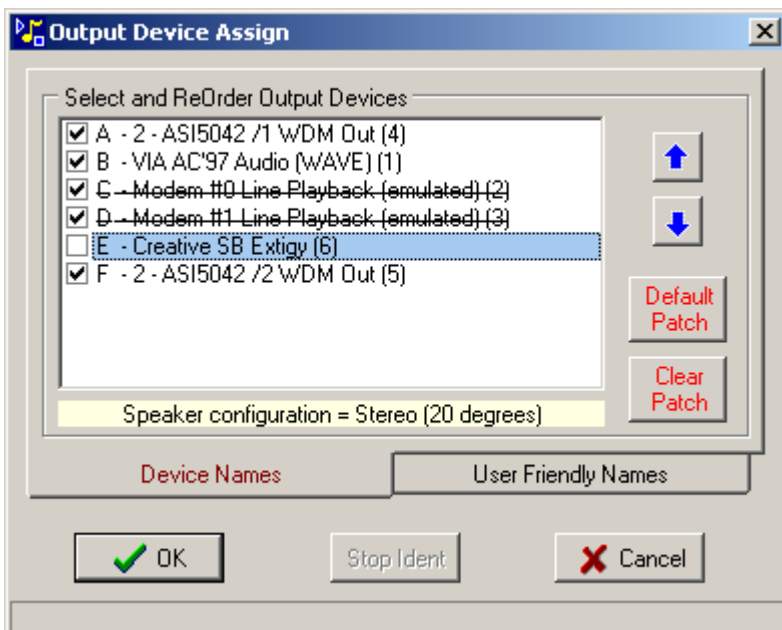

See [Output Device Assign](#) page

## Enter 5.1 Unlock Code

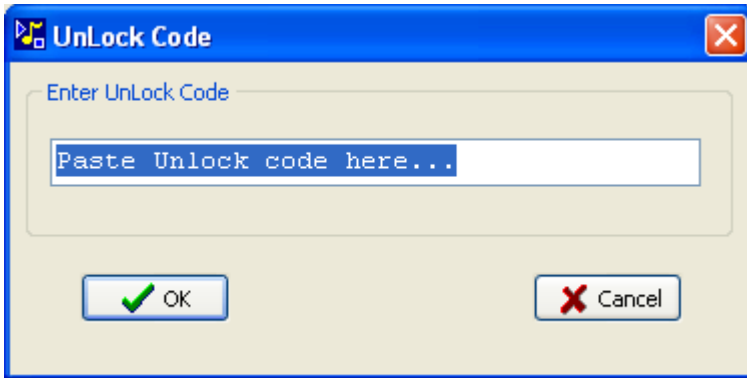

Before SpotOn can be used in 5.1 surround sound mode, an unlock code must be entered, the unlock code will be supplied when SpotOn upgrade is purchased.

If the unlock code supplied is of the form `"/multi6 /MCA1CF316F76107CE"` then the code should be entered without prefix `"/multi6 /MC"`

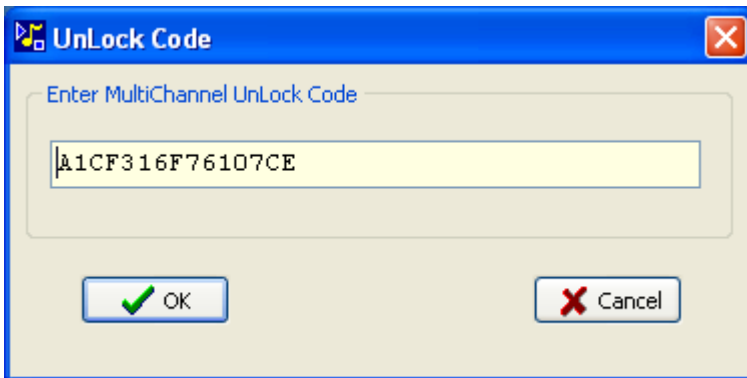

If the code entered was found to be invalid a warning dialog box is shown



If the code was valid then a shortcut placed on the Windows desktop.



## Enter P2 Unlock Code

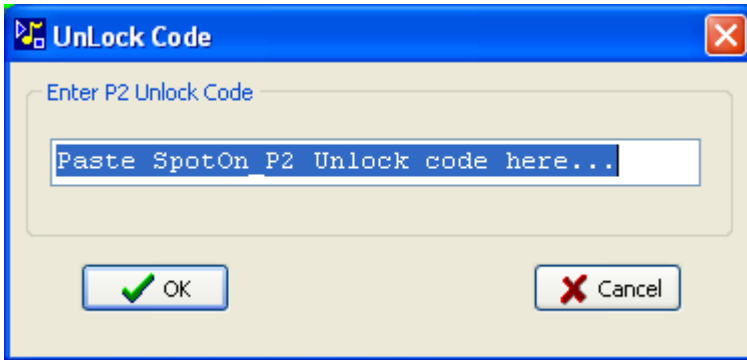

The SpotOn\_P2 utility is installed with SpotOn but not enabled, to enabled it enter the unlock code in one of the two formats shown below.

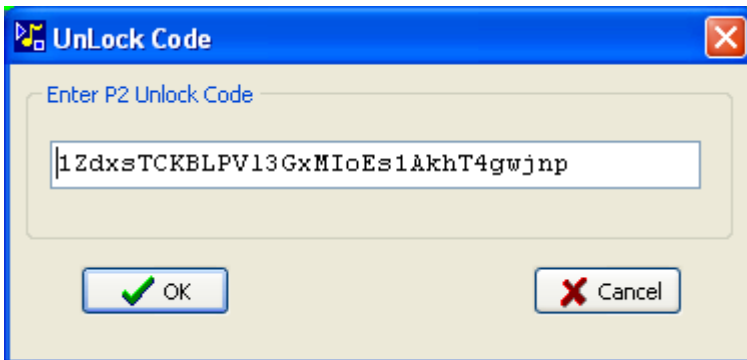
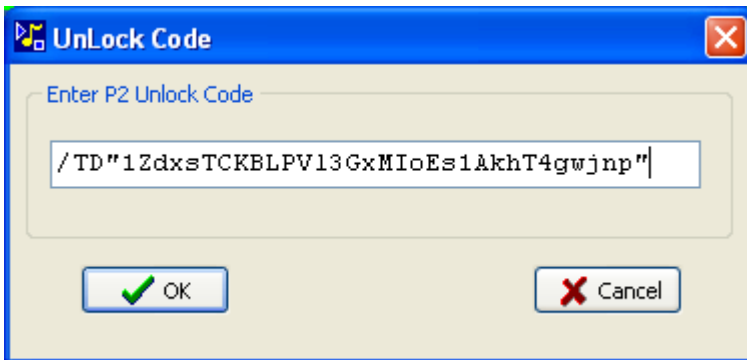

## Enter XK Unlock Code

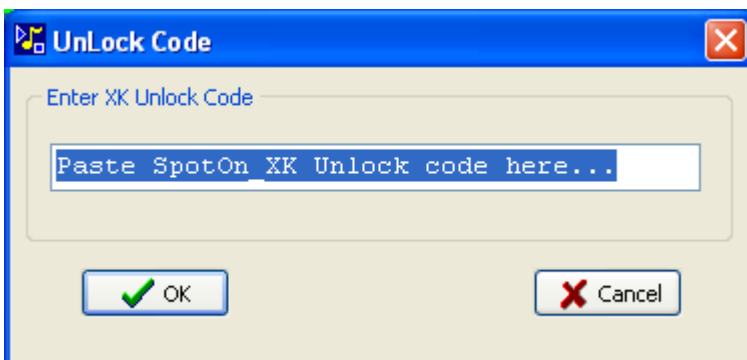

The SpotOn\_Xk utility is installed with SpotOn but not enabled, to enabled it enter the unlock code in one of the two formats shown below.

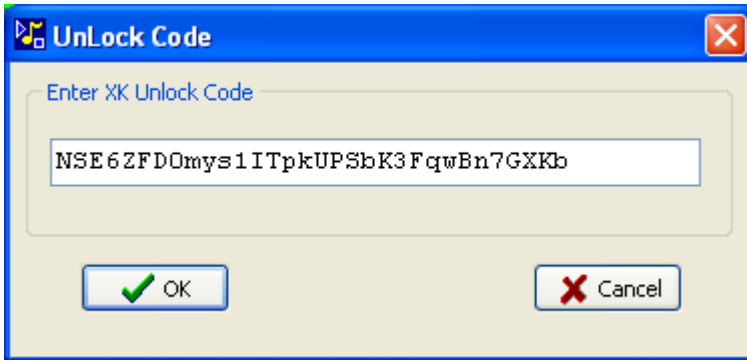
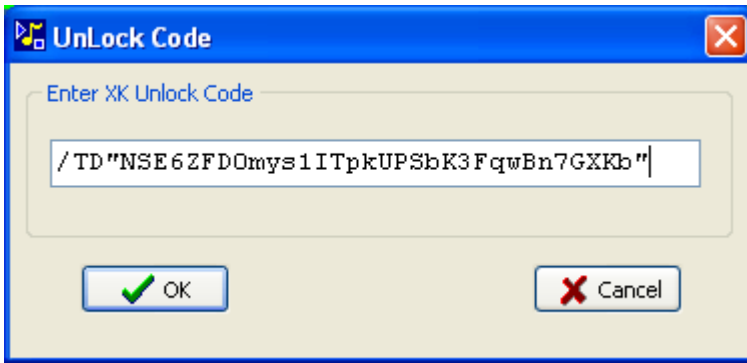

### Ignore Emulated Output Devices

With some sound card drivers a single output may be presented with more than one implementation, below an AudioScience ASI5044 card shows two entries "/1 Wave Out (Emulated)" and "/01 WDM Out" that refer to the same output device.

The WDM version is the one preferred for use with SpotOn, so to allow this to be used the "Emulated" version must be ignored by checking the Ignore Emulated Devices option.

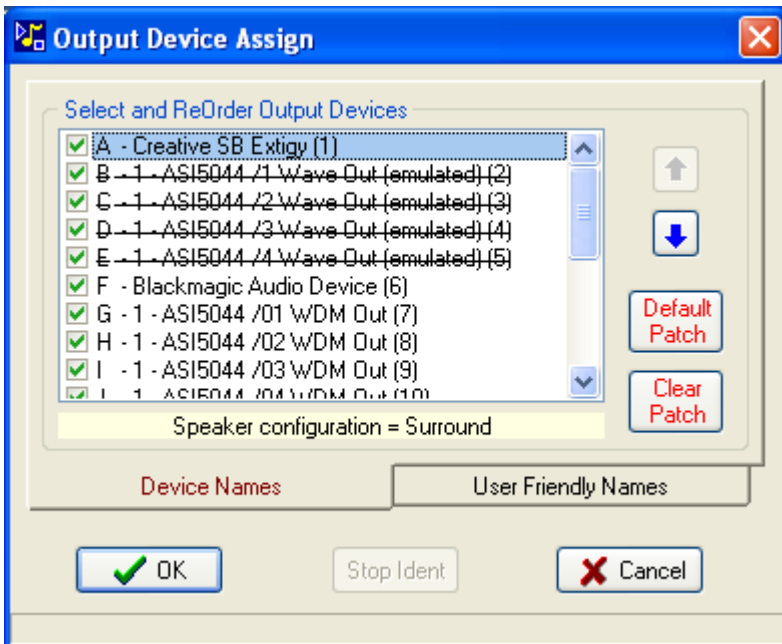

## Misc

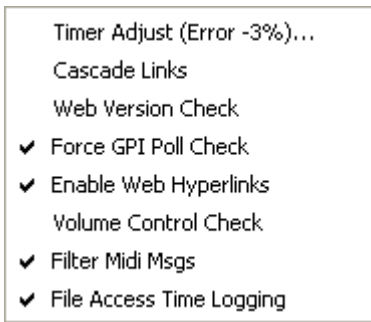

### Misc - Timer Adjust

Due to the variation in performance of the Windows timing routines it may be necessary to adjust the base timer period in SpotOn this can either be 20mS or 31mS.

The menu item text shows the error, in the example below timer is 3% too long a +/- 15% error is acceptable

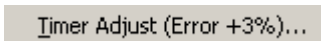

If the option is chosen to change the timer period then the following confirmation dialog box will be shown

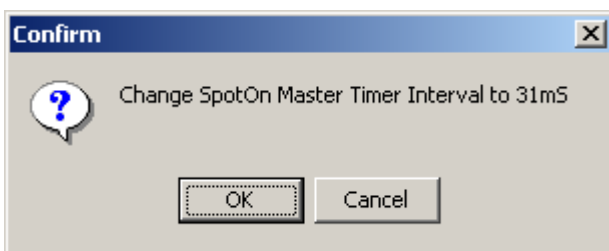

### Misc - Cascade Links

In normal operation of Master/Slave links, the Play Slave link is only effective if the Master button has been triggered by a mouse click or external trigger.

The Play Slave link is not effective if the Master button has been played as a result of itself being a Play Slave.

For example if Btn 2 is a play slave of Btn 1 and Btn 3 is a play slave of Btn 2, playing Btn 1 will play Btn1 and the slave Btn 2, the play slave on Btn 3 will not automatically be triggered.

When the Cascade Links option is checked the play slave action can itself be triggered from another play slave, so in the case above, playing button 1 will cause buttons 1, 2 & 3 to play.

There is a trap to fall into with Cascaded Links, it is now possible to set up an infinite loop where a Master button ends up being triggered by itself via various Master/Play Slave links. Playing such a link could lock up SpotOn and require Task Manager to close it down, so to avoid this a limit of 32 cascaded links has been set.

Warning dialogs will appear when an infinite loop is detected.

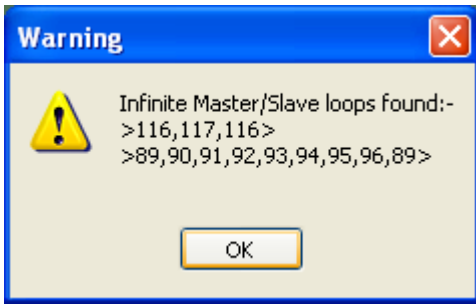

### Misc - Web Version Check

If [Web Hyperlinks](#) are enabled SpotOn will attempt to check each week for new updates, if a new version is ready for download then a message dialog similar to the one shown below will appear.

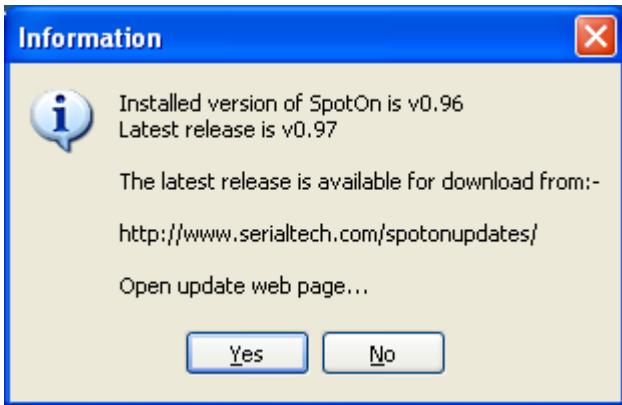

If Admin mode is enabled and an update is not available then a message will be shown indicating the current and latest versions

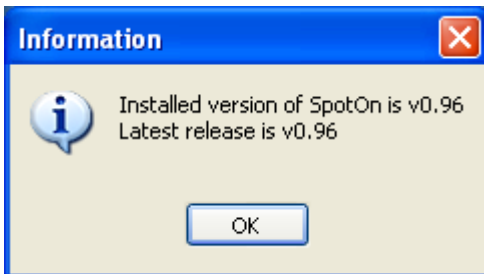

### Force GPI Poll Check

Only present as a debug aid, SpotOn continuously poll GPI devices and if a device is disconnected whilst SpotOn is running it can cause problems by modulating the audio output with a 50Hz square wave.

With this option unchecked, as soon as the device is detected as being disconnected it is removed from the polling list and so the disturbance is minimised. However, this is then sensitive to a poor connection to the GPI device which may be briefly unplugged in which case the GPI would be disabled until reassigned.

### Misc - Enable Web Hyperlinks

In the situation where a WWW internet connection is not provided the help menu options that access the internet can be disabled

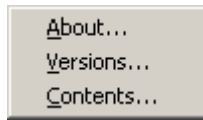
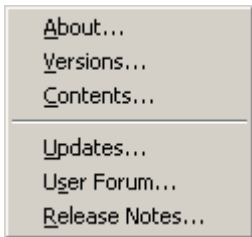

### Misc - Volume Control Check

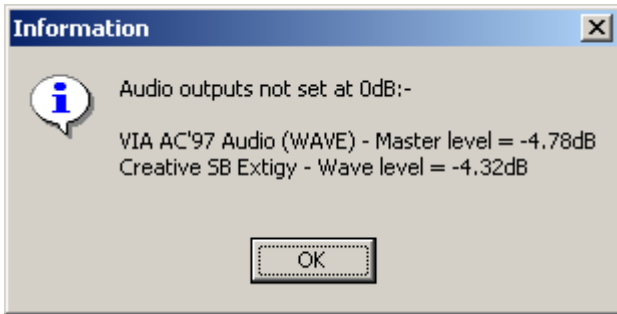

At startup SpotOn checks the settings of the Windows audio output levels, if any are not set to maximum (0dB) then a warning message is displayed, unchecking this option suppresses this warning dialog box.

### Misc - Filter Midi Msgs

When Midi messages are being received very quickly SpotOn may not have time to implement all the actions, Filter Midi Msgs option was added to only act on the last messages for each channel/Note - intended for Debug use only.

### Misc - File Access Time Logging

Indicates whether the Operating System keeps a record of when files were last accessed, when enabled this can slightly slow down file access speeds.

### Speed Bar Lower Limit

The speed bar shown in the [Audio Setup](#) dialog window has an upper limit of 400% (4x normal speed) and a lower limit set by the following menu option in the range 1%..25%

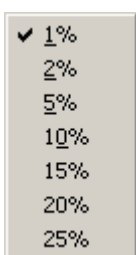

- 1%
- 2%
- 5%
- 10%
- 15%
- 20%
- ✓ 25%



This setting also applies to the floating SpeedBars

## Primary Mixer Frequency

- ✓ 44.1kHz
- 48.0kHz

The audio tracks are mixed together to form the main output of SpotOn, as the tracks could have different sample rates they all have to be converted to a common rate before mixing, this rate can be either of the two standards 44100Hz or 48000Hz.

SpotOn will have to be restarted for this change to take effect.

## Old Menus

- ✓ Grid Lines
- ✓ Timed BackUp
- ✓ GPI In Icons
- ✓ Fast File Save
- ✓ Use Play Delay
- ✓ Midi In/Out Icons
- ✓ Stop Page Button
- ✓ Use WAV Preview
- ✓ Show Pages Playing
- ✓ Flash Phase Locked
- ✓ Highlight Step To Next
- ✓ Enable All Stop Button
- ✓ Narrow Track Numbers
- ✓ Edged Midi/HotKey Text
- ✓ Flash Button during Play
- Optimize Tracks ▶

## Old Menu - Grid Lines

Under some circumstances it may be necessary to highlight the gaps between the buttons, this option adds a grid of white lines between the buttons

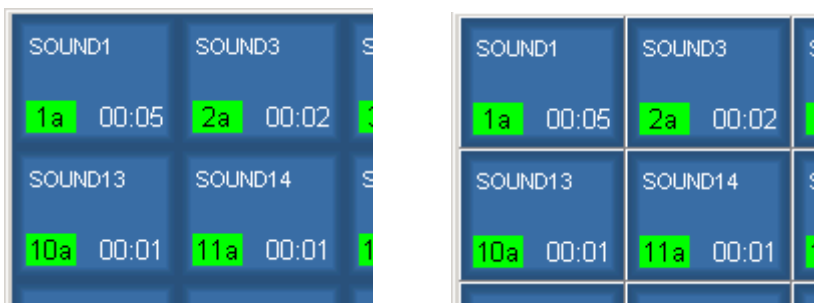

## Old Menu- Timed BackUp

Backups of the current session are automatically made every 5 minutes and the last 16 files are retained - which equates to 80 minutes usage

## Old Menu - GPI In Icons

By checking this option buttons that have GPIs assigned can be indicated by an extra button icon, a diamond on the left hand edge

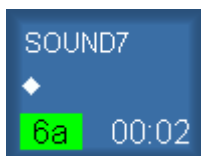

## Old Menu - Fast File Save

There are two methods of regularly saving system files in the background task routines, checking this item will cause SpotOn to use the "Fast" method instead of the "Threaded" method - intended for Debug use only.

## Old Menu - Play Delay

Allow delayed play on Play Next and linked Slave buttons

## Old Menu - Midi In/Out Icons

In order to easily see which buttons have Midi In or Out assignments this option adds the button icons shown below designating Midi In and Midi Out respectively



## Old Menu - Stop Page Button

In addition to the All Stop button which stops all tracks on all pages, there is a Page Stop button which will stop all tracks on the current page, by default the page Stop button is hidden.

The All Stop button can be enabled/disabled via [this menu](#)

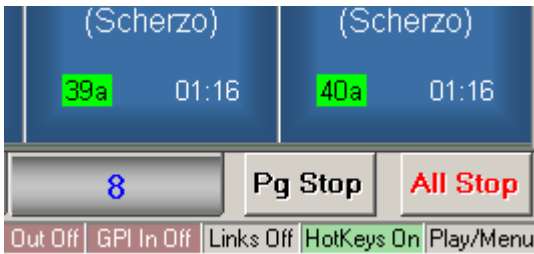
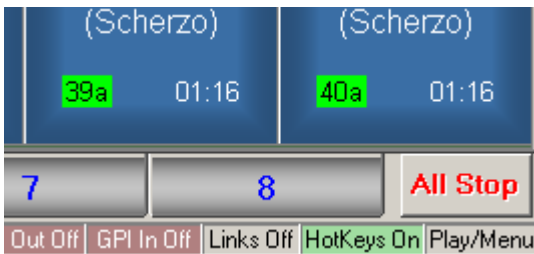

### Old Menus - Use WAV Preview

Checking this option adds a track preview area to the "Load" file selector dialog

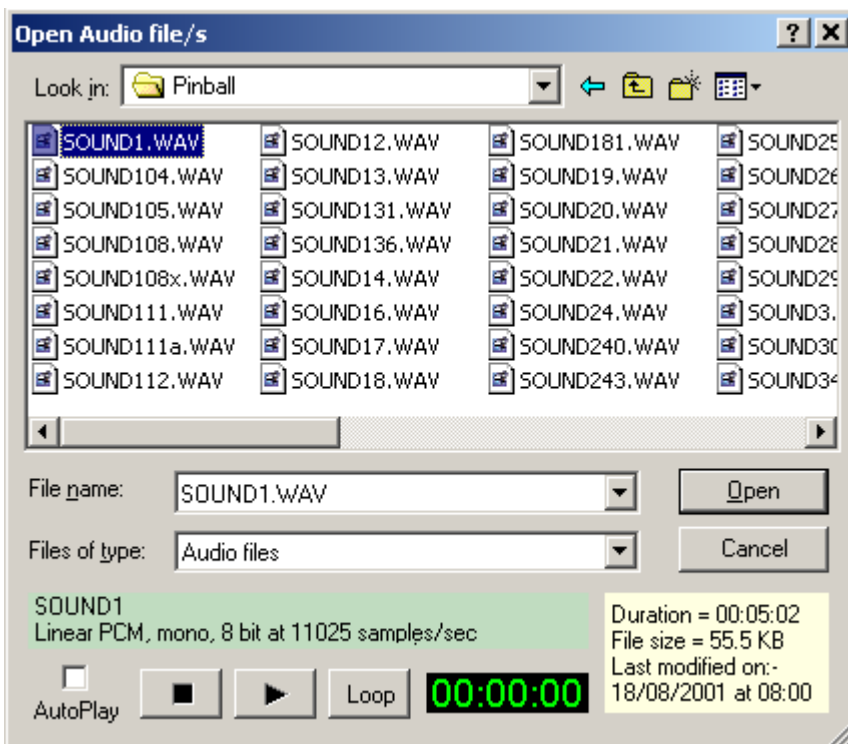

The track will be played out on the output assigned to the button about to be loaded at the [default output level](#)

### Old Menus - Show Pages Playing

As an aid to know on which page tracks are being played, this option marks the page tabs in the upper left corner with a red triangle, this will flash if the Options|Flash Button During Play option is set.

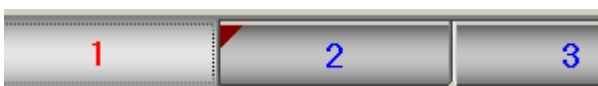
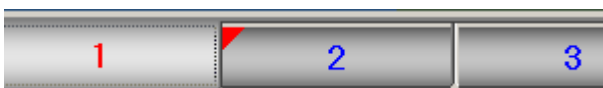

### Old Menu - Flash Phase Locked

Synchronize flashing of all button numbers

### Old Menu - Highlight Step to Next

Step to Next mode shows the selected button with a white background to the track number



In some circumstances this may not be obvious on the screen so the Highlight Step to Next option adds extra highlighting in the corners of the button



### Old Menu - Enable All Stop Button

This will disable/enable the All Stop button in the status bar

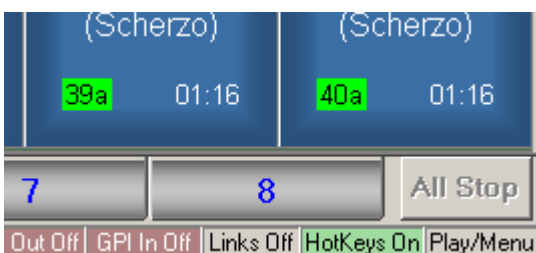
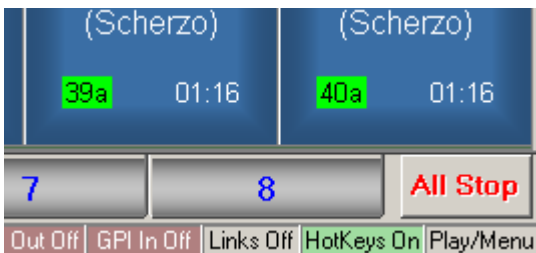

## Old Menus - Narrow Track Numbers

The coloured background on the track numbers sometimes extends over the duration numbers, so hiding some or all of the modifier symbols.

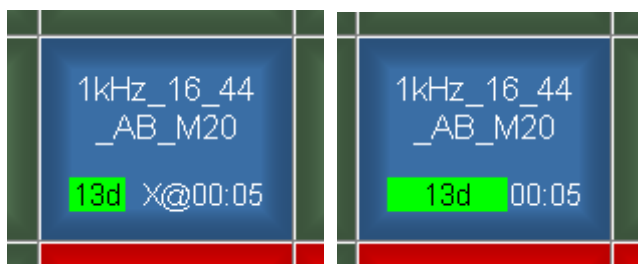

Links Off

Links On

In the situation above the switching on of the Master/Slave links causes the green text background to extend towards the right hand side of the button, this is to allow for indication of all the possible combinations of links. All buttons on a page have the text background set to the same width.

To reduce the instances of the track number hiding the duration modifiers the Narrow Track Numbers option can be checked, this will set the width of the background to be as wide as possible whilst avoiding overlapping the duration text except when absolutely necessary.



Links On

Links On

## Old Menus - Edged Midi/HotKey Text

In order to improve visibility of the button Midi and HotKey text this option will add a drop shadow effect to the text



## Old Menus - Flash Button During Play

Flash button number bright/dark red when playing

## Old Menu - Optimize Tracks

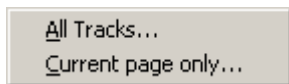

Tracks can be optimized either globally covering all tracks on all pages, or just on the current page, so assigning the most frequently played tracks to hardware mixers.

## Use Win XP Themes - enabled by default

Check the Use Win XP Themes\_menu item to enable the Windows "XP theme" look when running under Windows XP or above, SpotOn will have to be restarted for this to take effect.

XP themes disabled:-



XP Themes enabled:-



Note: the actual representation will depend on the particular color scheme selected under WinXP themes, and consequentially the readability of some sections of the program may be reduced.

# Output Device Assign

## Output Device Assign - Clear Patch

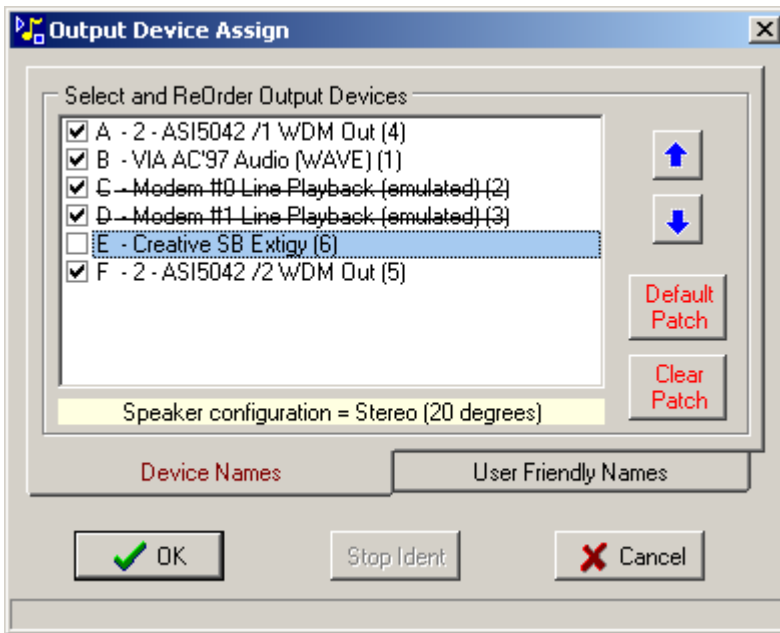

When assigning outputs for the first time or after a change of output devices eg Multi-channel/Stereo, it is recommended that the Clear Patch button is used to clear any ambiguous settings in the SpotOn configuration file.

Clicking on Clear Patch will display the dialog box below

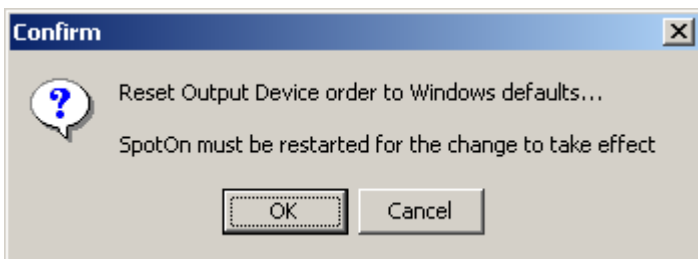

Choosing OK will close the Output Device Assign dialog and return to the main SpotOn screen.

## Output Device Assign - Default Patch

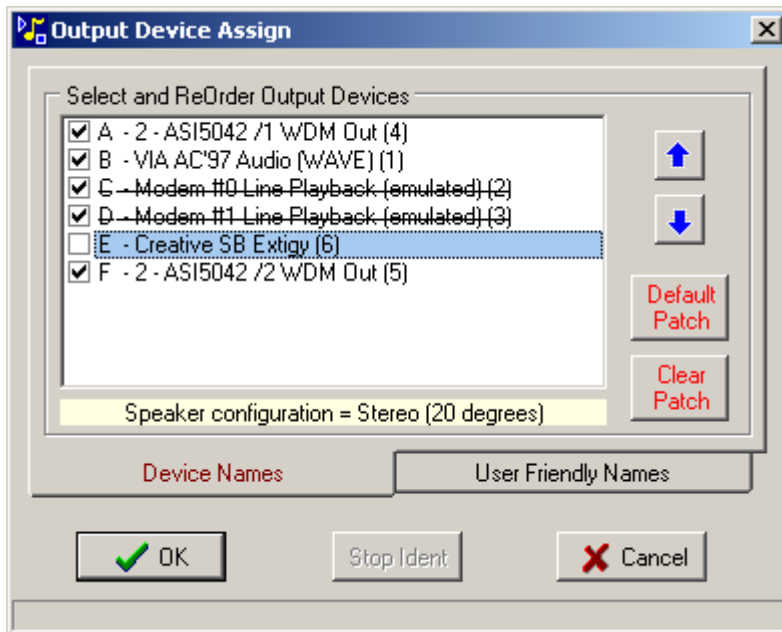

The Default Patch is saved on installation when the outputs have been initially configured. If necessary the Default Patch button will return the output device patch and masking to the installation settings.

Clicking on Default Patch will display the dialog box below

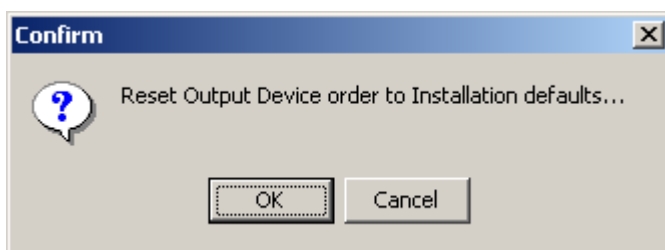

## Output Device Assign - Masking

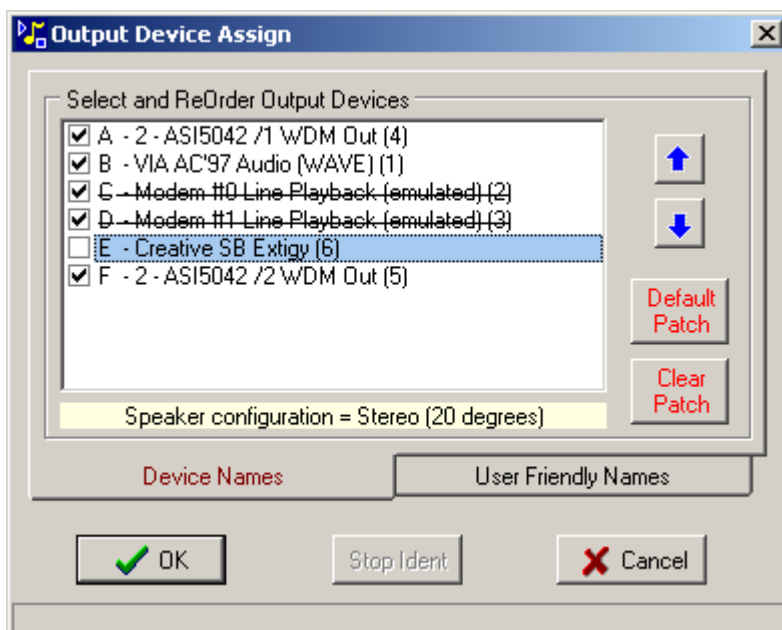

Some sound cards do not allow more than one application to access an output port simultaneously, in this case it is useful to force SpotOn to not use a specific output port so making it available for other applications.

In the example above there are seven output ports listed A..F.

Items A, B and F are sound card outputs being used by SpotOn

Items C and D are not available because they are virtual outputs provided by two modems and not in fact real sound card ports.

The remaining item E has been unchecked and therefore will be masked out of ports used by SpotOn, the masking of ports will only take effect the next time SpotOn is restarted. If there are buttons using any port/s that are masked on restart then those buttons will be assigned to device designated as the Windows Preferred audio output device, designated by the subscript '(1)' in the device list. If the Windows preferred audio output device is also masked then the buttons concerned will not be loaded.

After a restart output E is shown in red text

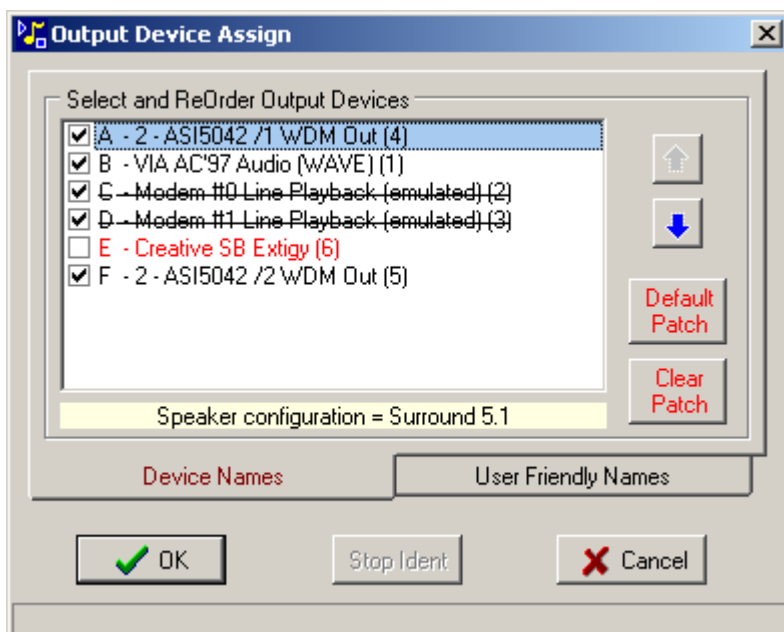

The example below shows the effect of masking outputs in the [Audio Setup](#) dialog, where output E cannot be selected.

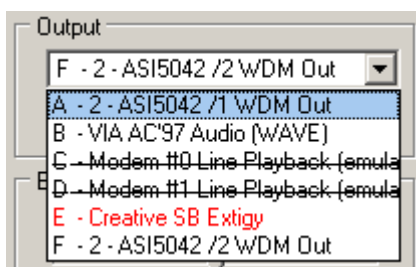

## Output Device Assign - Order

The up, down and reset buttons on the right hand side of the window allows the ordering of the output devices.

If outputs currently known as A and D were to be the main options it would be useful to move them to the first two positions in the list so appearing as A and B

To do this first highlight the line describing output D

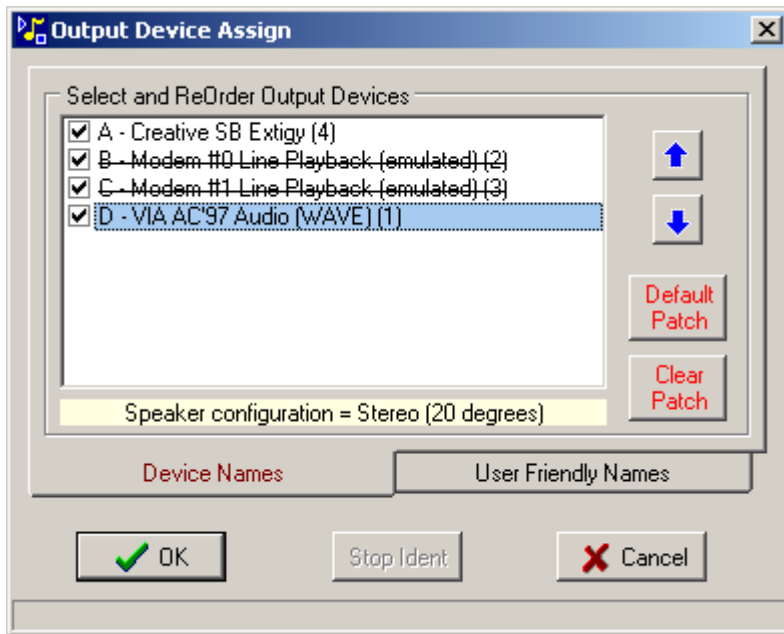

By clicking the up arrow twice the order now appears as

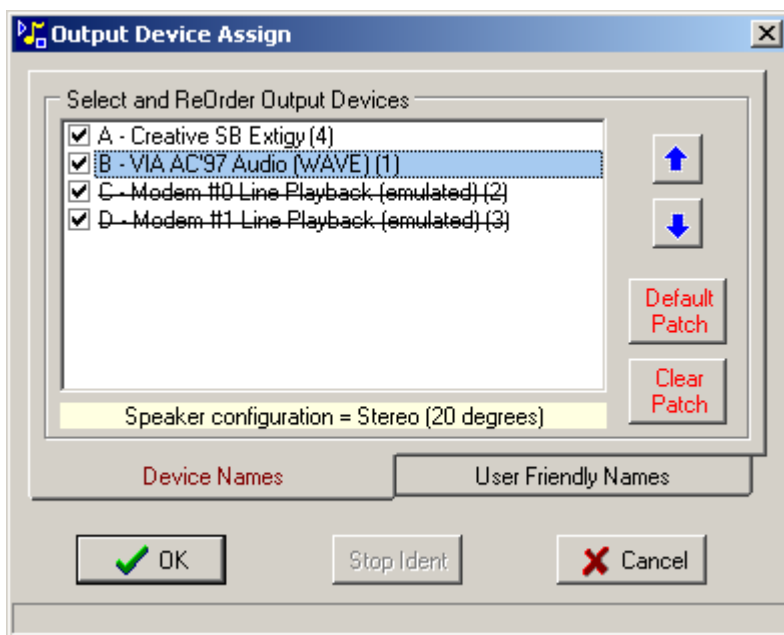

Reset Order button will restore the output device order to that which was found by the Windows OS.

Identically loaded computers may not always report the output devices in the same order, so this option is useful in making the computers 'look' the same to the user.

Exiting with OK produces a confirmation dialog box to warn that all buttons will be reloaded to in order to implement the change

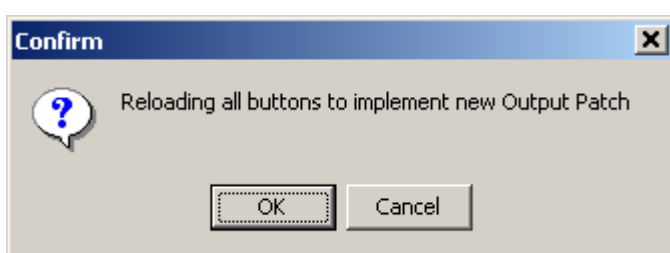

## Output Device Assign - Names

The names that appear alongside the output ports are those obtained from Windows, often more informative names are required, selecting the User Friendly Names tab show the alternative names defined - these initially default to the Windows name.

The new names are enabled via the Options|Display|Use Friendly Output Names menu item.

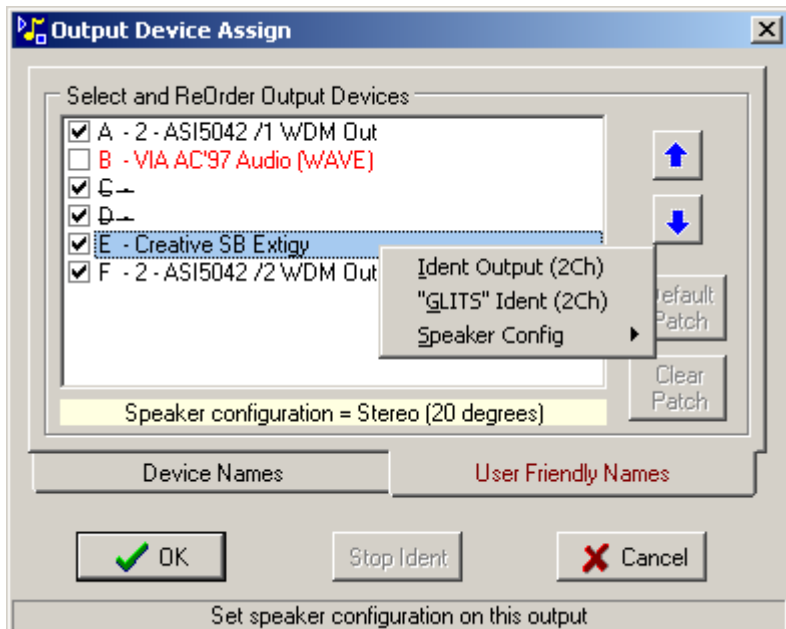

Right-click an entry and select Edit User Name, which displays the edit box below

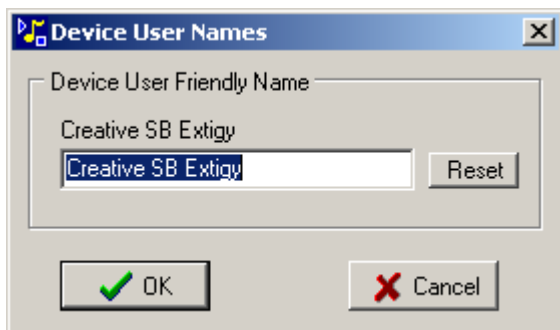

Enter the new name

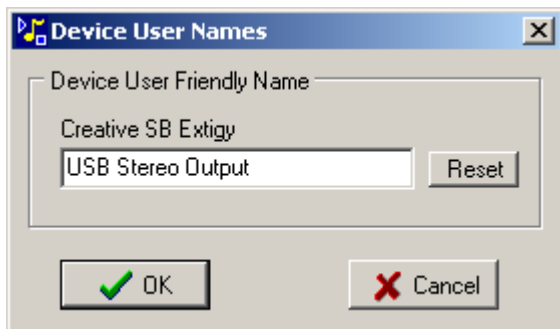

On closing the editor the name is up dated

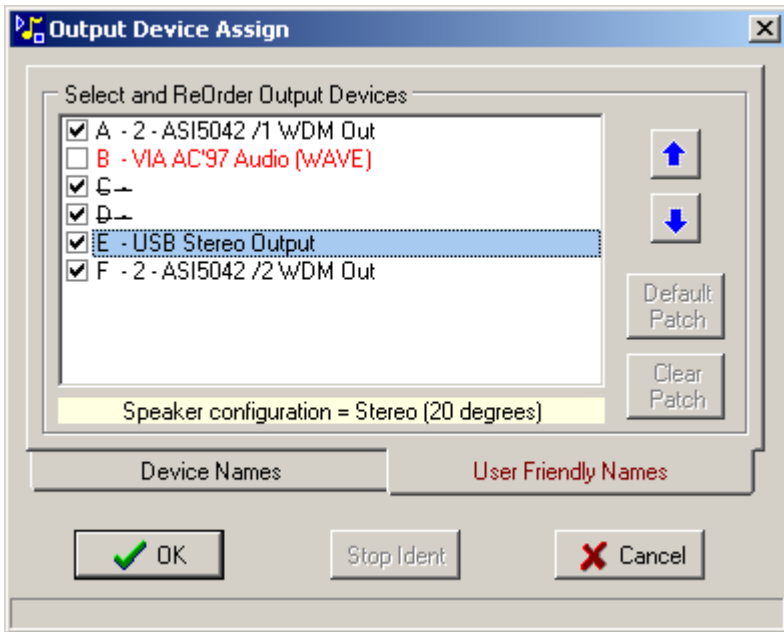

The User Friendly Names are only used in the button menu - option Audio|Output as below:-

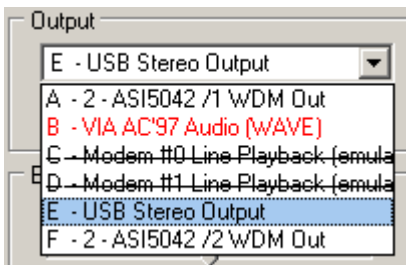

### Output Device Assign - Mode

Under the list of output devices there is a panel showing the 'Speaker Configuration' of that output

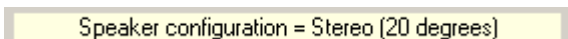

To change the 'Speaker Configuration' right-click an entry and select the Speaker Config option.

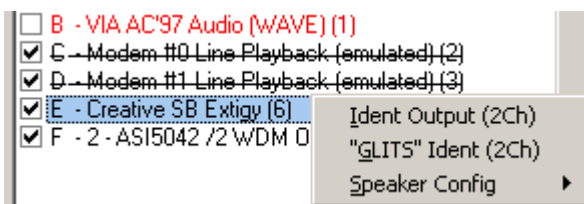

The full list of modes is shown with the three most common modes enabled.

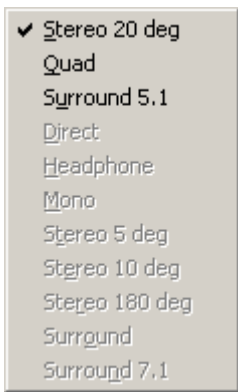

Check the appropriate option to change the mode of that output, in some cases it will also be necessary to use the manufacturers setup utility to change the hardware mode.

### Output Device Assign - Idents

As SpotOn can operate in conventional 2 channel stereo and multi-channel modes, it may be useful to identify the individual output ports.

To identify output right-click the entry and select Ident option, this will start a voice ident loop spanning all output channels.

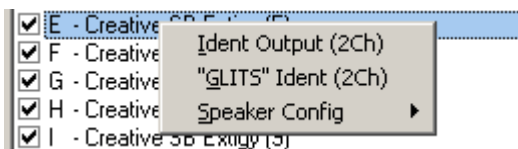

The "GLITS" test tone sequence is available for stereo sound configurations and is formed by interrupted 1kHz tone with one break on the left channel followed by two breaks on the right channel.

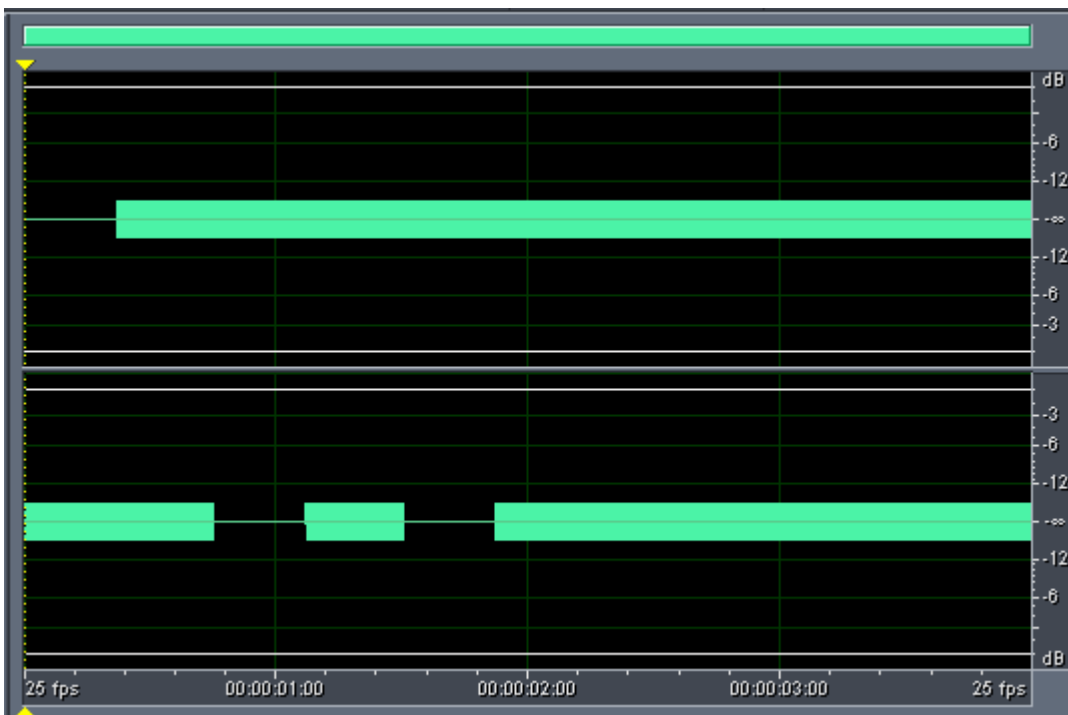

Similarly the "BLITS" test tone sequence is available for 5.1 surround sound configurations - see [BLITS](#) page for further details

<input checked="" type="checkbox"/> A - 2 - ASI5042 /1 WDM Out (4)	Ident Output (6Ch)
<input type="checkbox"/> B - VIA AC'97 Audio (WAVE) (1)	"BLITS" Ident (6Ch)
<input checked="" type="checkbox"/> C - Modem #0 Line Playback (em	Speaker Config ▶
<input checked="" type="checkbox"/> D - Modem #1 Line Playback (em	

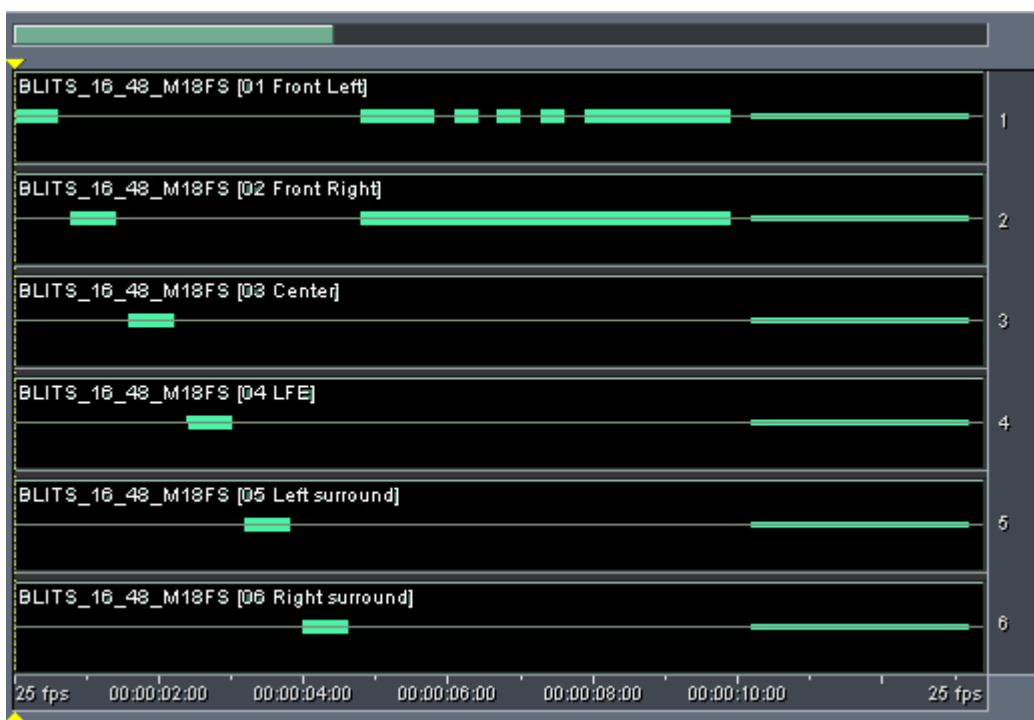

# Help Menu

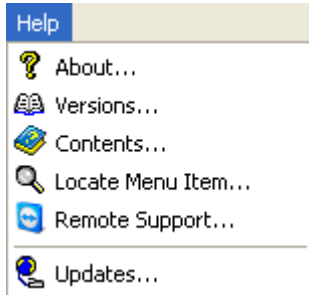

- About Just displays an 'About Box'
- Versions Shows Versions page from help file
- Contents Opens this help file
- [Locate Menu Item](#) Search dialog for finding menu items
- [Remote Support](#) Utility to provide remote support of the SpotOn system

\*Updates Accesses SpotOn updates web page

\*Enabled via [Admin menu](#)

## Locate Menu Item

The dialog below allows the menus to be searched for a keyword, the search term 'button' lists 18 items.

The results shown in blue text are hyperlinks to menu dialogs and can be clicked to open up the appropriate dialog box.

The format of the results includes the main menu item followed by a number of menu subitems eg Options | Display.

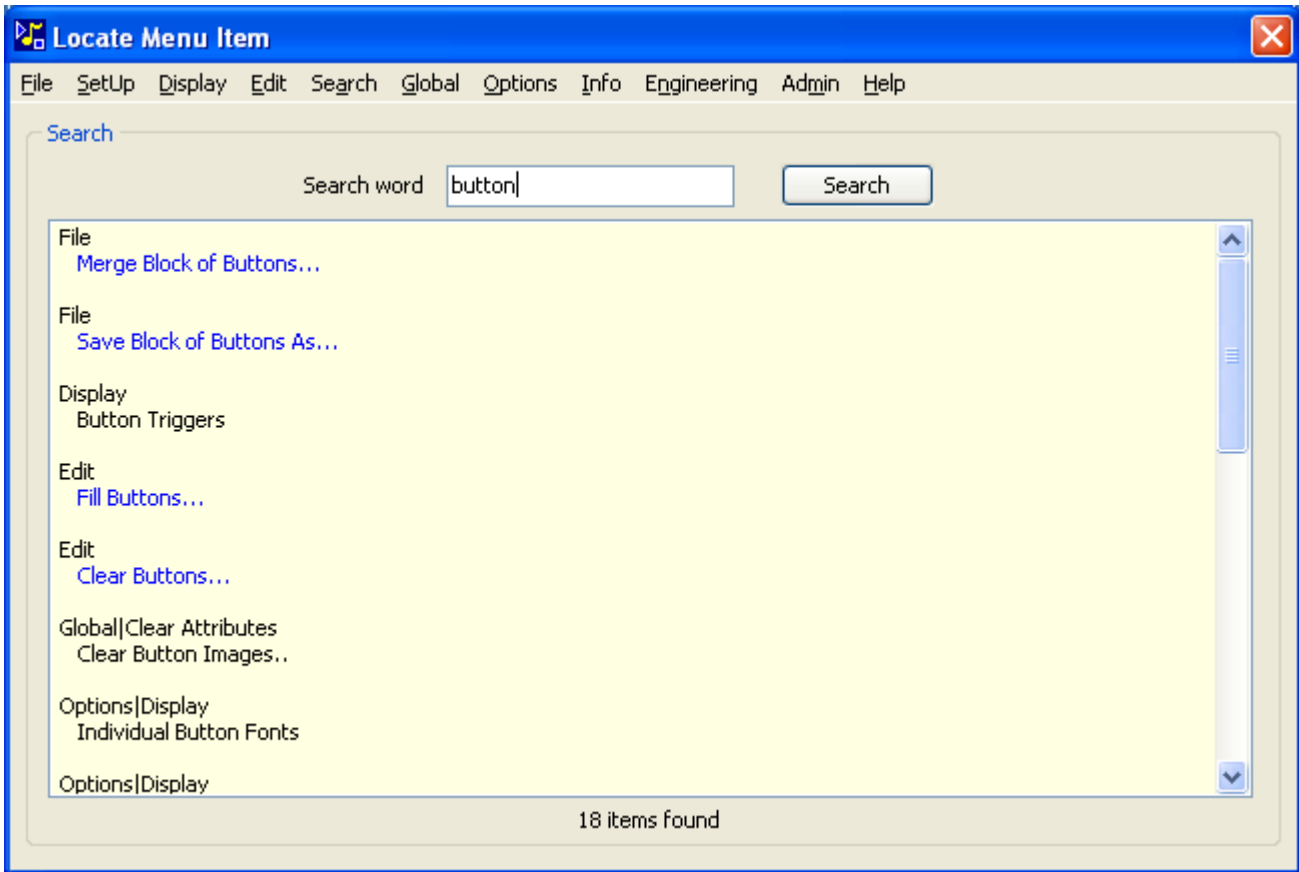

The menu bar shown at the top of the dialog is a copy of the main SpotOn menu and is live.

## Remote Support

Remote support is available for SpotOn, prior arrangement with the supplier is required for this facility. The [TeamViewer](#) utility is used to provide remote access to the SpotOn computer.

A client application needs to be run on the local computer to allow access.

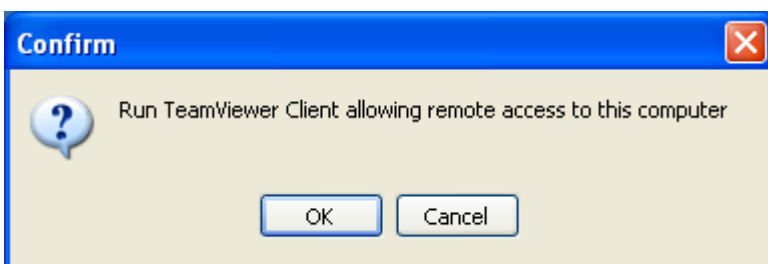

The ID and password displayed on the SpotOn computer should be passed on to the SpotOn supplier so that remote access can be initiated.

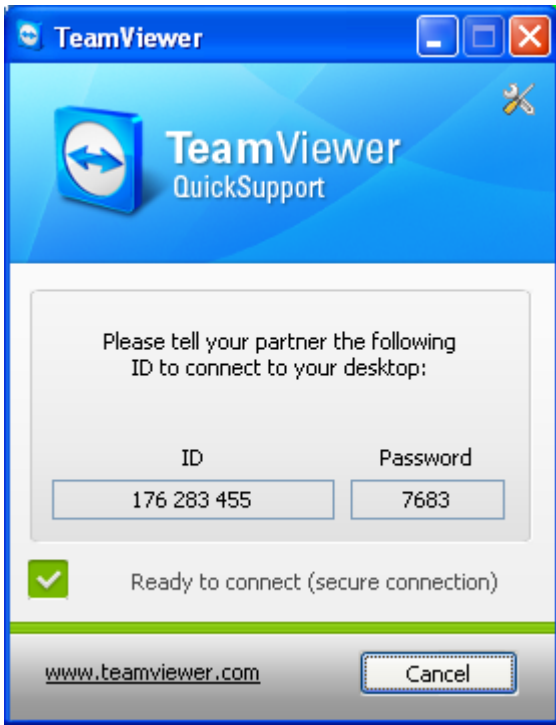

# Button PopUp Menu

C <u>u</u> t	L <u>o</u> op
C <u>o</u> py	S <u>t</u> op All <u>o</u> n Play
P <u>a</u> ste from 1	P <u>l</u> ay N <u>e</u> xt
P <u>a</u> ste C <u>o</u> lor	E <u>d</u> it with A <u>u</u> diti <u>o</u> n...
P <u>a</u> ste S <u>p</u> ecial	M <u>i</u> di...
S <u>w</u> ap with 1	A <u>u</u> dio...
C <u>l</u> ear...	D <u>i</u> splay/ <u>H</u> otKeys...
L <u>o</u> ad...	<b>C</b> ancel

The items in the left hand column deal with the button as a whole, the items on the right cover the parameters of the track loaded into the button.

The **Cut**-to clipboard, **Copy**-to clipboard and **Paste**-from clipboard options allow tracks to be moved between buttons, Paste Colour will take the colour of the "Copied" button and paste it to a destination button enabling say, a set of buttons with similar sounds to have the same colour.

**Swap** will exchange the button "Copied" to the clipboard with the destination button.

**Clear** will remove all references to a track from a single button

**Load** and **Browse** display file selection dialogs for loading of tracks to buttons.

The first three items in the right hand column as options that can be checked or unchecked.

**Loop** when checked will cause the track play command to start playing the

**Stop All on Play** if this option is checked when the track begins to play all other tracks being played will fade out using their individual fade times, this is indicated by a small square halfway up the right hand edge of the button.

Alternatively tracks can be set to stop immediately without fades by muting the audio on this button (see [Audio Setup](#)), in this case the square box icon is replaced by a square outline

An advanced operation of Stop on Mouse Up is available by ctrl+clicking this option. When selected the track will play whilst the left mouse button is held down and stop when it is released, the mode is indicated by a white outlined red square on the right hand side of the button

**Play Next** checking this option will cause the track contained in the next highest button to play when this track reaches the end, this is indicated by a small right facing arrow halfway up the right hand edge of the button

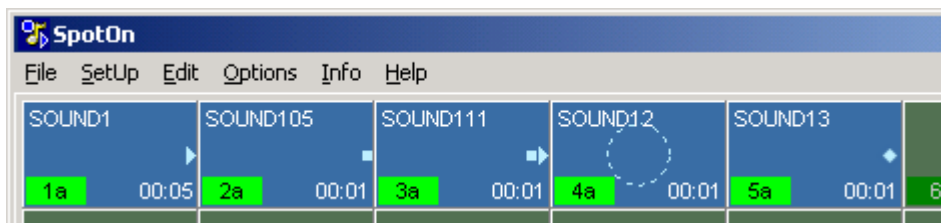

When the track on button 1 reaches the end, Button 2 will begin to play

When button 2 plays any other tracks that may be playing will be stopped

When button 3 plays it will also stop any other tracks that are currently playing and will then play button 4 when the track on button 3 reaches the end.

Button 4 is set to loop continuously

**Edit** opens up the user defined WAV file editor, this editor is selected via Setup|Editor menu

**Midi** see [Midi Assignment](#)

**Audio** see [Audio Setup](#)

**Display** see [Display Options](#)

For a full description of the popup menu options see [Button Menus](#) page

# Button Menus

Right-clicking on an unassigned button will show the load menu

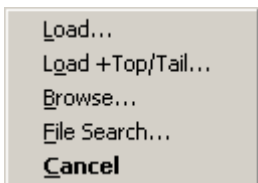

offering three options [Load](#) , [Browse](#) and [File Search](#)

Right-clicking an unassigned button that is displaying a 'File not Found' message will show one additional option [Locate File](#) which allows the user to locate a WAV file that SpotOn cannot find.

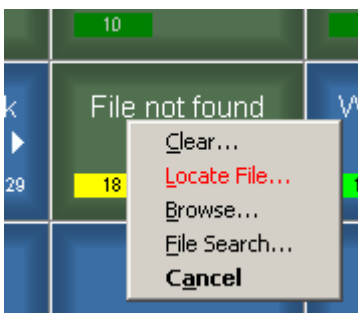

If an assigned button is right-clicked then a more extensive set of options is available

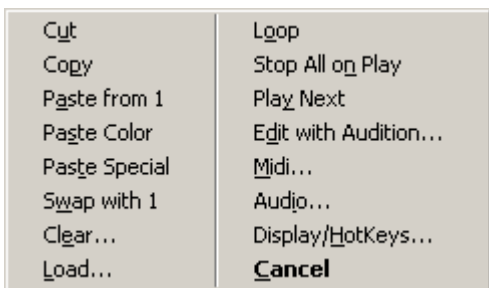

<a href="#">Cut</a>	<a href="#">Loop</a>
<a href="#">Copy</a>	<a href="#">Stop All on Play</a>
<a href="#">Paste</a>	<a href="#">Play Next</a>
<a href="#">Paste Color</a>	<a href="#">Edit...</a>
<a href="#">Paste Special</a>	<a href="#">Midi...</a>
<a href="#">Swap</a>	<a href="#">Audio...</a>
<a href="#">Clear...</a>	<a href="#">Display/HotKeys...</a>
<a href="#">Load...</a>	<a href="#">Cancel</a>

## Cut

Removes the track from the button and places it on the clipboard

## Copy

Copies the track on the button to the clipboard

## Paste

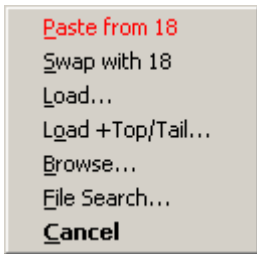

If the clipboard contains a track then it will be loaded onto the selected button

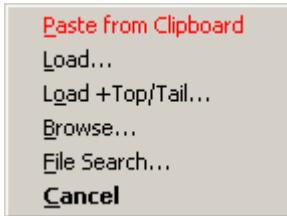

If there is a file that has been 'cut' or 'copied' to the Windows clipboard outside of SpotOn then that file will be available to paste onto the button



Instead of the specific operations of cut, copy and paste buttons can be moved and copied using a drag and drop method.

Shift drag/drop will move a button showing the cursor  and similarly control drag/drop will copy a button with cursor 

Drag/drop can be used across pages, the pages are changed by dragging the button over the page tabs at the bottom of the main window.

### **Paste Color**

Pastes the only the color information from the clipboard track onto the selected button, used to set a group of buttons to the same color

### **Paste Special**

Pastes one or more selected settings from the clipboard track onto the selected button, see [Edit|Paste Special](#)

### **Swap**

Exchanges the track that has been previously copied to the clipboard with the track on the selected button.

Copying button 3 (track A) to the clipboard and then Swapping with button 12 (track B) will result in button 3 being loaded with track B and button 12 being loaded with track A

### **Clear**

Clears the contents of the button, the original audio track is not deleted

### **Load**

This opens up a file select dialog as described in [Getting Started](#) in order to load one or more tracks onto buttons starting at the selected button.

If tracks are loaded in a compressed format eg MP3 or from a remote/networked disc, then a local uncompressed copy of the file will be made. The default location of this folder is set in the [File Folders](#) dialog, however each time a new local copy needs to be made the option to redirect the file to a more

relevant folder is offered. the 'No To All' button will be shown when more than one file is selected for loading.

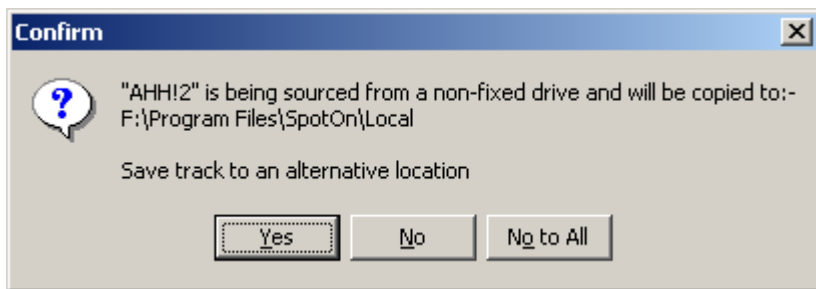

Clicking Yes will display a folder selection dialog

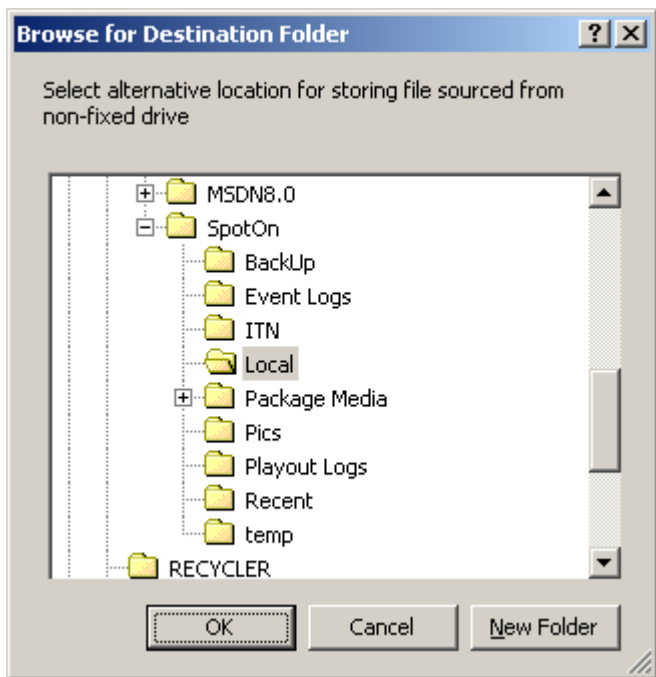

The destination folder selected can be saved for the duration of the session, that is until a new session is loaded, by selecting Yes in the dialog below

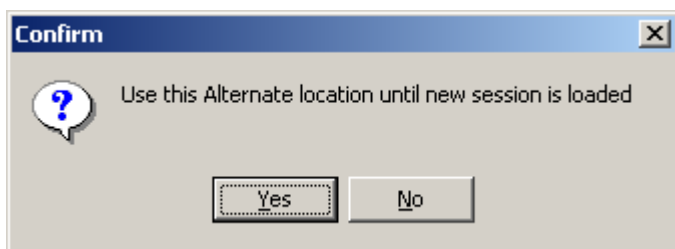

This facility is used where the files are to be saved in a nominated folder for a particular show rather than a general temporary folder.

### Load - CD Track

It is possible to load a CD track directly onto a button, without having to use an intermediate CD ripper.

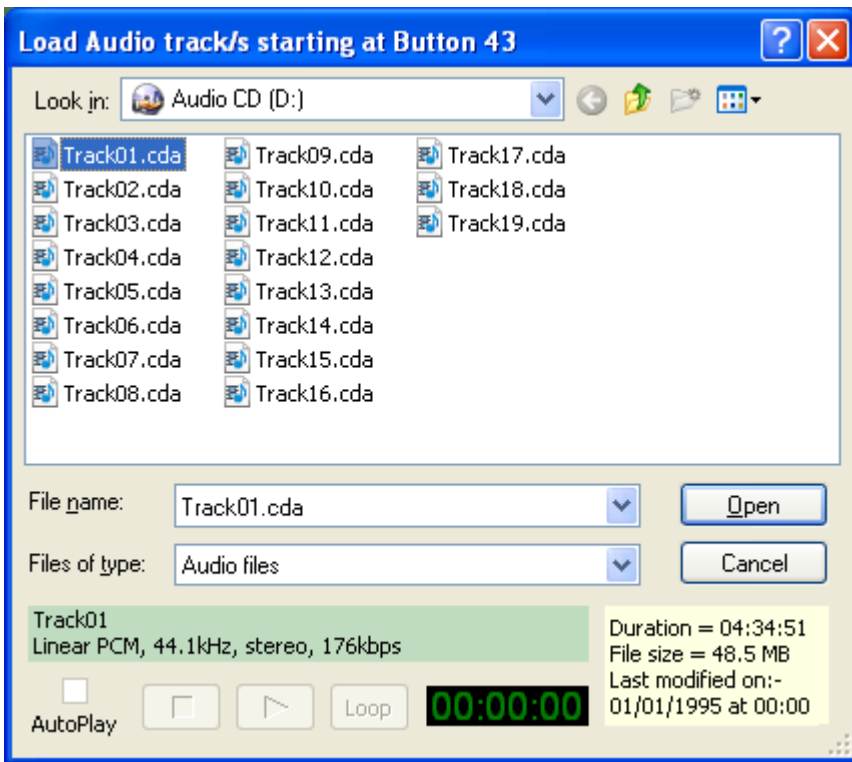

In SpotOn v0.96 and above an extended range of metadata is saved with the WAV files and inserted into the PlayOut logs.

The metadata for the CD track can be entered manually or looked up using an internet based database providing [Web Links](#) are enabled.

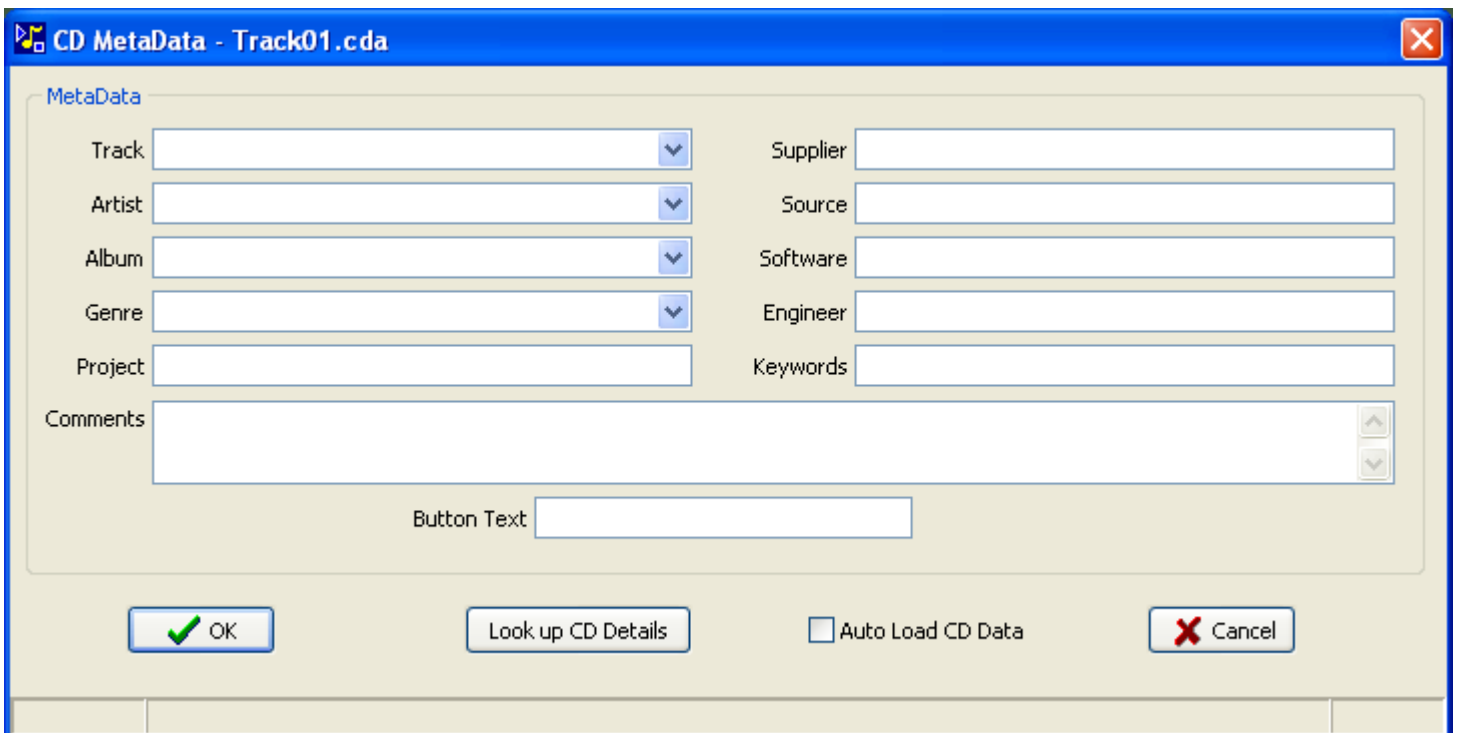

Clicking on 'Look up CD Details' starts the process of interrogating the remote database

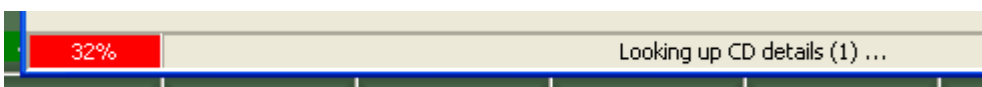

In the lower left corner of the window will be a progress counter, this will count up along with the data entry count in the centre of the status bar as the data is retrieved. The number in brackets (1) indicates the count through the multiple entries in the database.

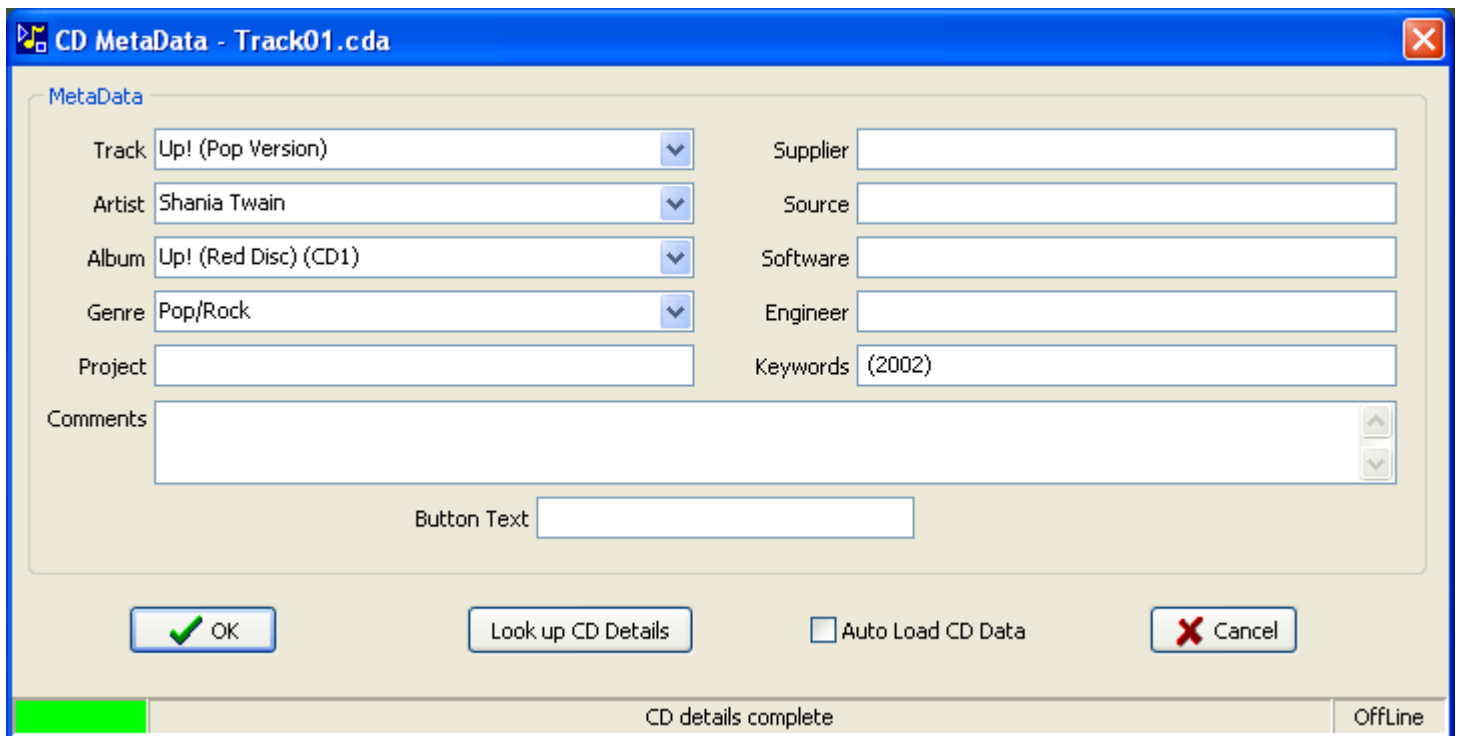
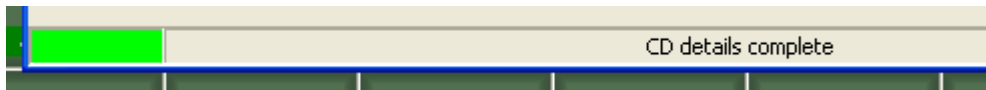

Sometimes the CD database has multiple entries for the same album/track, in which case the entries are shown in the drop down lists in each section

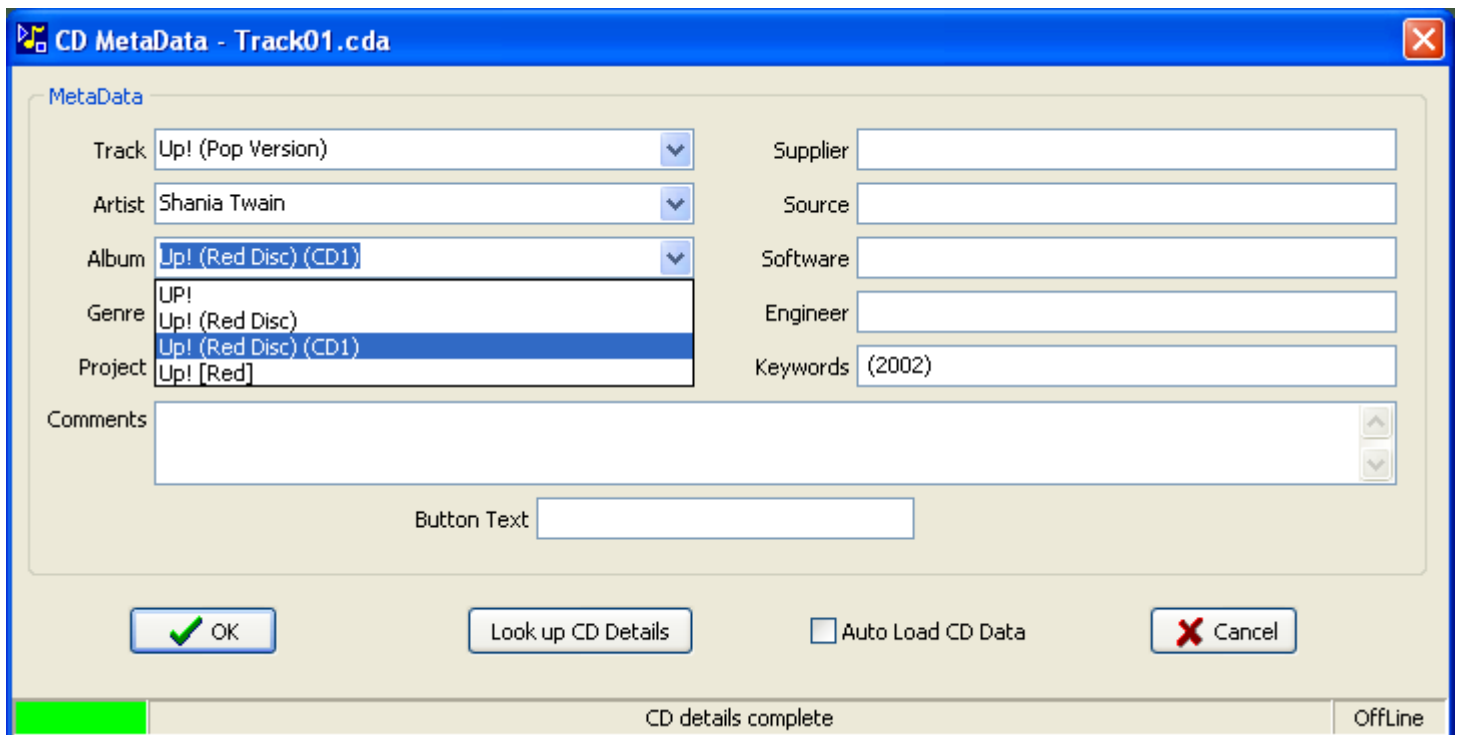

If the CD details lookup was successful then the filename of the extract track will be based on the CD track name

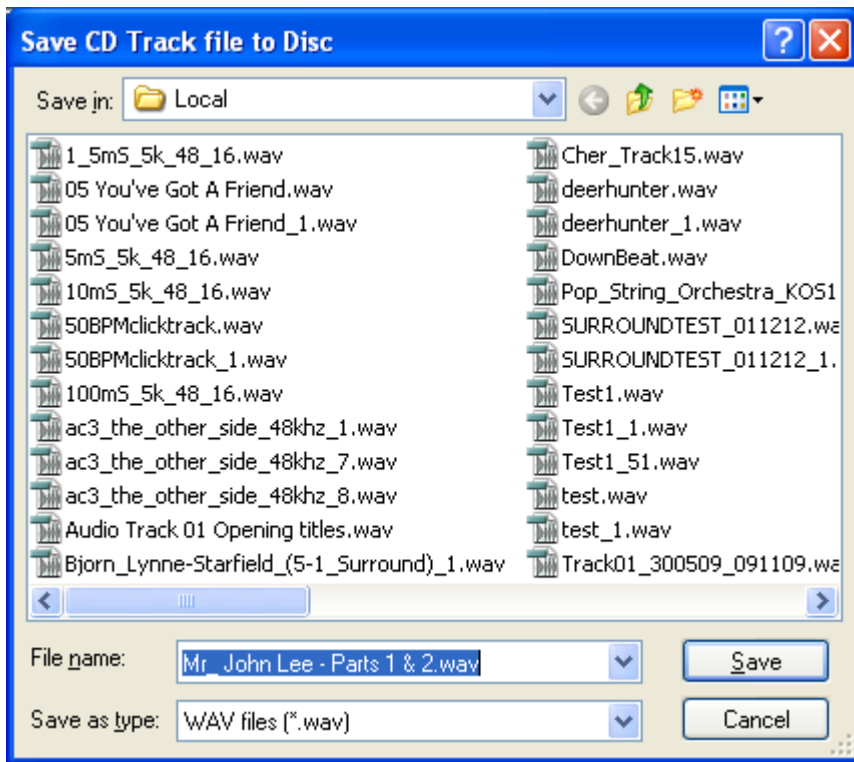

Alternatively if the CD details lookup failed or was cancelled then a default name will be used, the name is formatted from track number\_DDMMYY\_HHMMSS

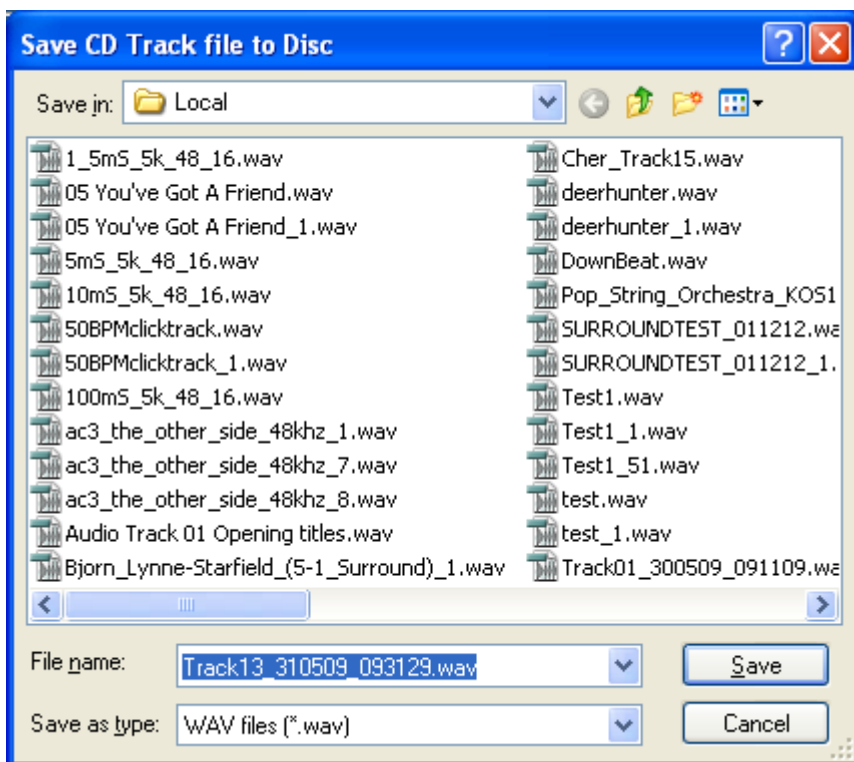

If multiple CD tracks are being loaded then the 'Auto Load CD Details' checkbox can be selected

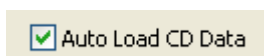

This will automatically look up the CD details and save the files without user intervention, the CD Metadata window is briefly held open during the process so the action can be interrupted.

## Browse

This opens up a Windows Explorer dialog as described in [Getting Started](#) in order to load one or more tracks onto buttons starting at the selected button, The main advantage over the Load option above is that the Windows Explorer dialog stays open and files can be dragged from Explorer onto the SpotOn buttons

## File Search

Runs a standalone utility SpotOnSearch which allows drives and folders to be scanned for audio files, the files can then be drag and dropped onto SpotOn

## Loop

Checking this option sets the track when played to loop continuously between its marked In and Out points, by default the In and Out points are set to the start and end of the track, See [Audio Settings](#) for information on setting the In and Out points

The Loop+ (LoopPlus) extension was introduced in version 0.95, this allows the Loop modifier to be changed whilst the track is playing without automatically stopping the track. In previous versions of SpotOn the track was automatically stopped when the Loop modifier was changed.



As of version 0.95 the text in the button popup menu changes from Loop to Loop+ when the track is playing, if the Loop+ option is changed from unchecked to checked the track will continue playing in a loop.

If the track is playing and the Loop+ option is changed from checked to unchecked the track will continue playing in a loop until it is stopped and then the loop modified will be removed. This state is indicated by the loop graphic changing from dashed to a solid circle.

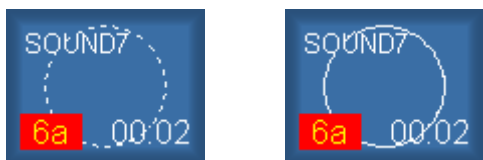

## Stop All on Play

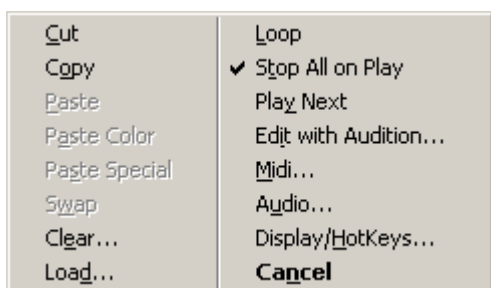

Checking this option will cause all other tracks currently playing to stop when this button is Played, the option is denoted by a block on the right hand edge of the button.

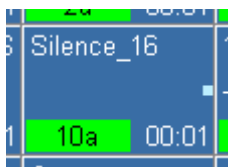

Normally all other buttons will stop using their fade out profiles, however if the button is also muted then the button icon is shown as a square outline and all other buttons will stop immediately.

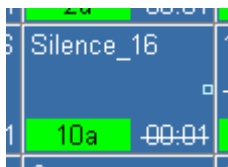

Advanced versions of Stop All on Play are available by shift+click or ctrl+click on this option. When selected the menu item caption will change.

For Shift+Click

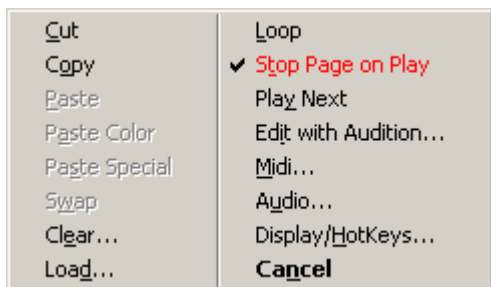

The Stop All on Play option becomes Stop Page on Play and the icon changes to a diamond, if the button is also muted then the button icon is shown as an outline and all buttons on the page will stop immediately.

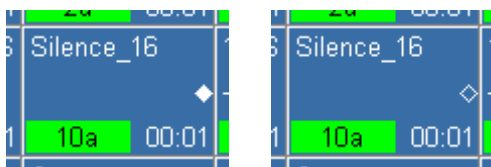

For Ctrl+Click

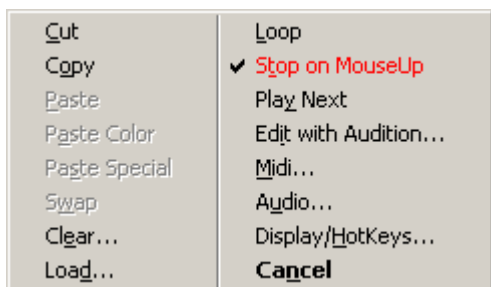

When active this option will cause the track to play whilst the left mouse button is held down and stop when it is released, the mode is indicated by a white outlined red square on the right hand side of the button.

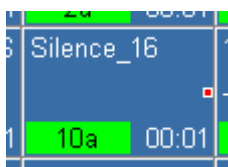

The left mouse button can be released without stopping the track if the Control key is held down as the left mouse button is released.

Note - the time between the left button of the mouse being pressed and released must be greater than the the default mouse click period.

## Play Next

Checking this option will cause button N+1 to begin playing when button N reaches the Out point, if button N+1 is unassigned no other button will be played. The option is denoted by a triangle on the right hand edge of the button.

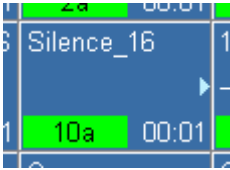

Both Play Next and Stop All options can be applied to the same button

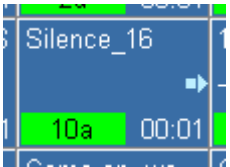

## Edit

Opens up an external WAV file editor, so that the track audio data can be modified. The track data held by SpotOn is not automatically updated when the audio is saved by the external editor, the Global|Refresh Tracks menu option will update the button data.

In default mode SpotOn will first copy the audio file on the selected button as a file named "Copy\_of\_..." and then open this file in the chosen editor application. The user is then responsible for saving the edited file either under a new filename and manually loading it onto a button or replacing the original file name and selecting Global|Refresh Tracks.

In [Advanced Editing](#) the mode changes to open the audio file being used by SpotOn without first making a copy, the user is then responsible for saving the file and selecting Global|Refresh Tracks on completion of editing, the advantage of this mode is that saving and reloading the edited file is much faster.

When opening some audio editing applications there may be a disturbance on the SpotOn outputs, a warning prompt box is displayed if this is likely to occur.

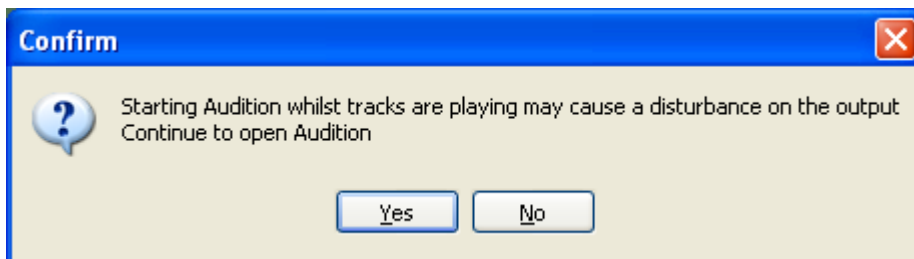

## Midi

Buttons can be played or stopped when defined Midi notes are received and similarly Midi notes can be transmitted when buttons are played, see [Midi Assignment](#) for details

## Audio

Various aspects of the track audio can be modified - gain, pan, speed, fade times and trim points see [Audio SetUp](#)

**Display/HotKeys**

The display name and colour of the selected button can be changed along with global settings for the button font styles, see [Display Options](#)

**Cancel**

Closes popup menu without performing any actions

# Display Options

This menu item contains three sections the first for editing the displayed track name, the second for customising button appearance and finally assignment of HotKeys.

## Names

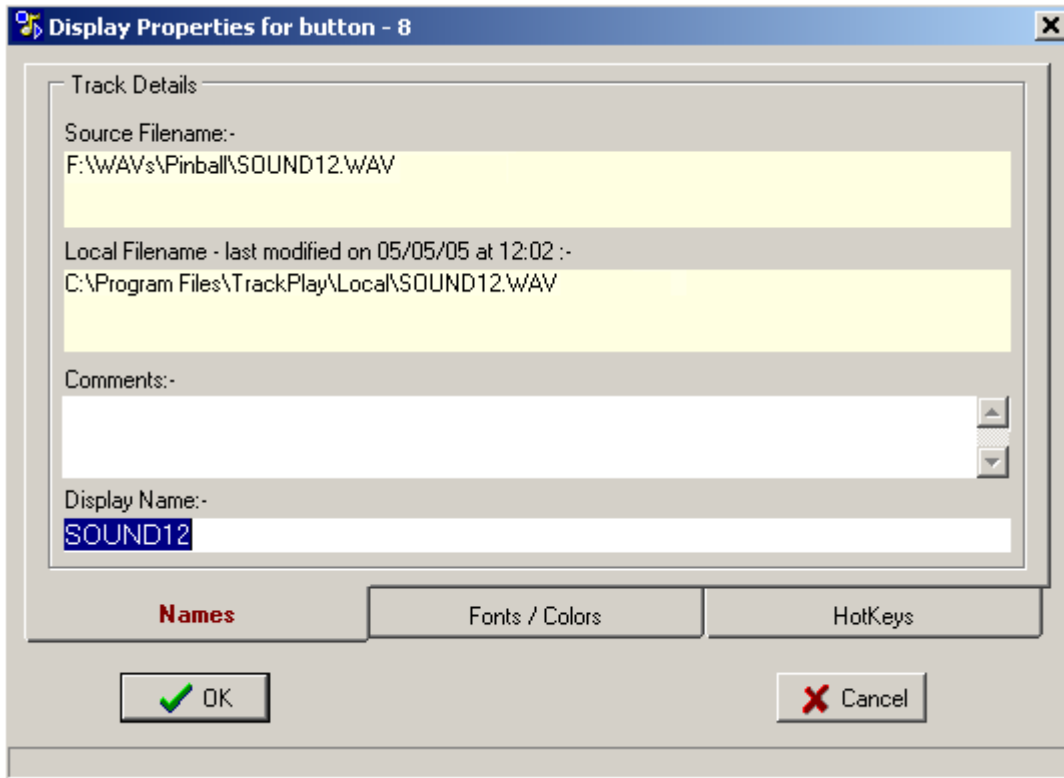

## Source Filename

The Source Filename label shows the full file path of the original file, if this file is on a fixed disc on the local machine then the Local Filename will be the same.

In the example above the source file was loaded from a CD mapped to drive F:, therefore SpotOn copied the file to a local directory.

If for any reason the source file could not be found when the dialog box opened then the filename will be shown in red text.

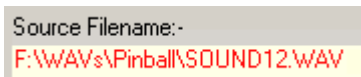

## Local Filename

Right-clicking in the display area will reveal a popup menu

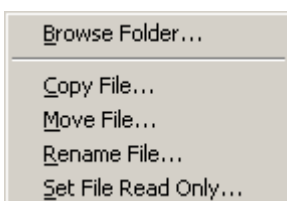

Browse Folder:-

Browse Folder will display a new Windows Explorer window showing the contents of the folder containing the current file, this may be useful if files from the same folder need to be loaded. To allow files to be drag and dropped from the Windows Explorer window the Display Options dialog is automatically closed by cancelling any changes.

Read Only:-

If the file on the local machine needs to be write protected then check the Set File Read Only item, this will display a confirmation dialog box to set the access rights to the disc file.

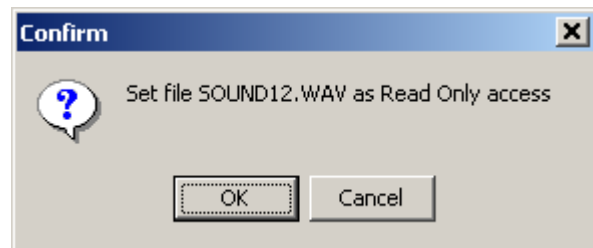
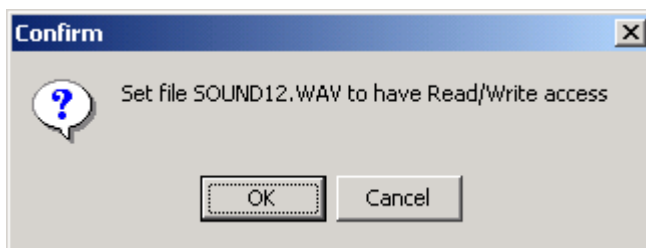
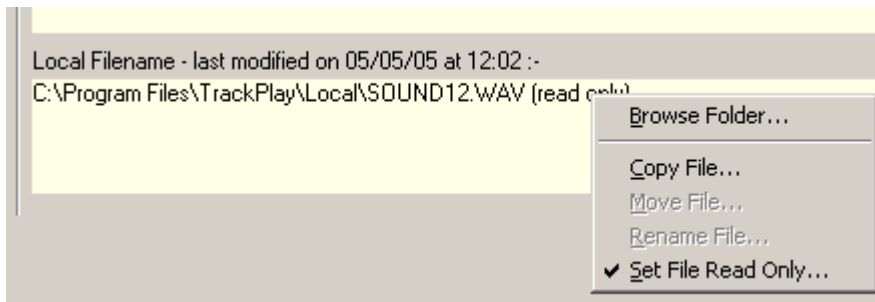

Rename File:-

If the file is not set to Read Only the local file can be renamed, this may be useful if the original filename was not descriptive and therefore difficult to locate.

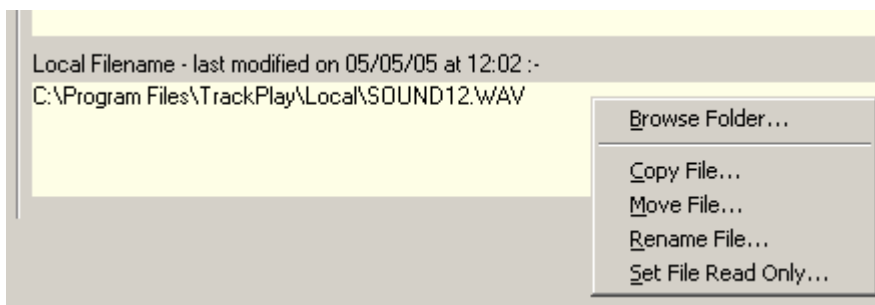

There are several consequences of renaming the file on the disk, the main two are that other SpotOn sessions referencing the file would no longer be able to find it, and similarly other separate applications that used the file would not function correctly.

Clicking on Rename File offers an edit dialog box allowing a new name to be entered.

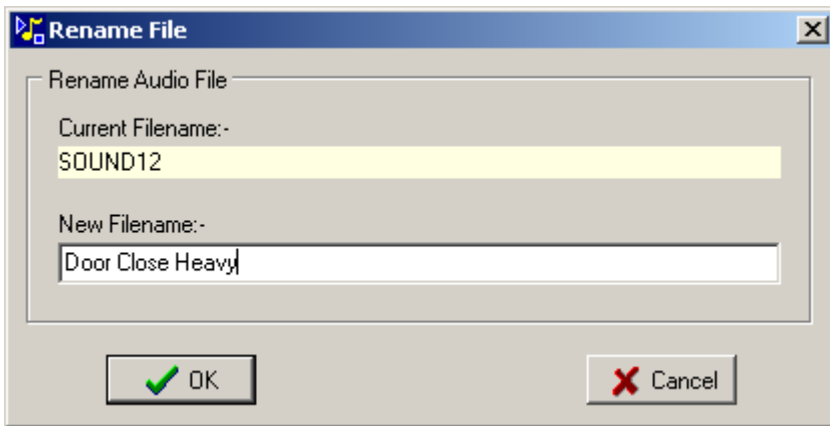
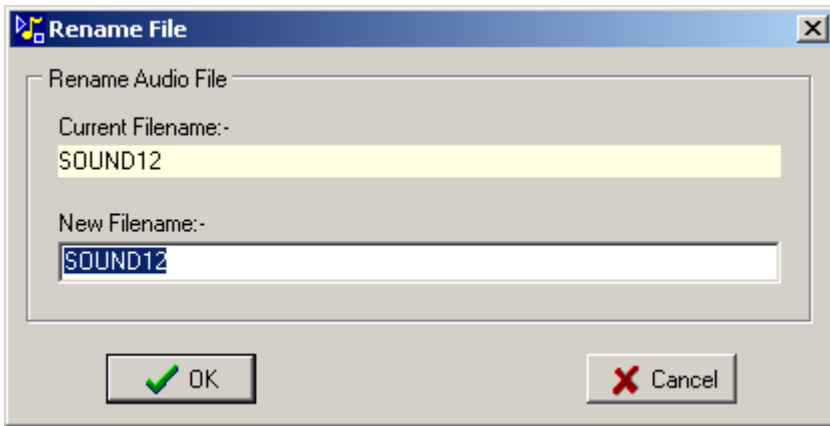

A prompt box will indicate if the filename already exists

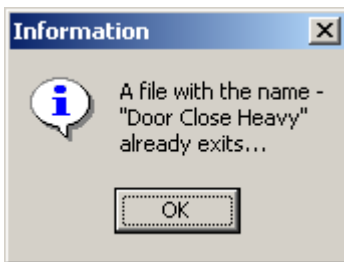

On exiting with OK the new name will be shown in blue text in the Track Details page

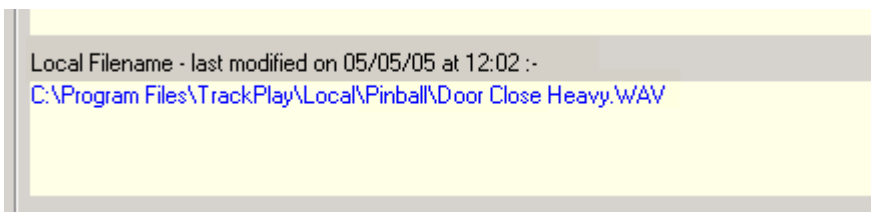

On exiting the Display properties dialog, a further warning will be shown, clicking on Yes will then rename the file.

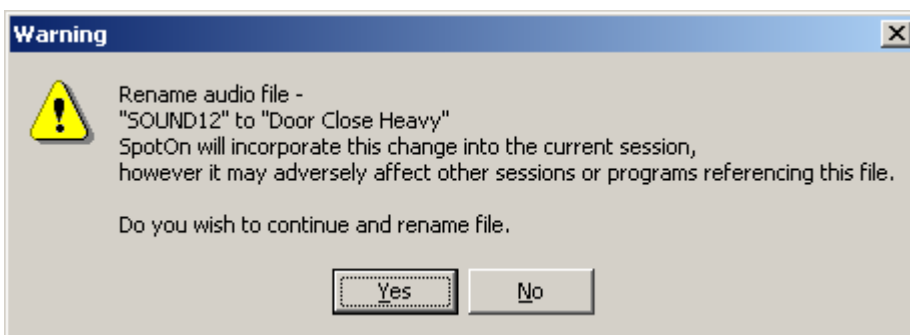

## Move File:-

The difference between Rename File and Move File is that Rename File will only change the filename and not the file path, so the file will remain in the original folder.

However with Move File, both the file path and file name can be changed so that the file could be moved to a new folder under a new name.

## Copy File:-

A copy of the existing file is made in a new location and the session modified to use the file in its new location.

The Read Only, Rename File, Copy File and Move File options are only enabled in [Advanced Edit](#) mode

## Comments

A comments can be associated with each button, the initial entry is taken from the Comments Field in the WAV file otherwise it defaults to 'none'

Below is an example of a Wave file editor (Adobe Audition) showing the Text Fields embedded in the file, the Comments section upper right is the field that SpotOn imports.

The screenshot shows the 'Wave Properties' dialog box with the 'Text Fields' tab selected. The 'Text Field Names' dropdown is set to 'Standard RIFF'. The 'Display Title' field is filled with '1KHz sinewave Tone'. The 'Original Artist', 'Name', 'Genre', 'Key Words', 'Digitization Source', 'Original Medium', 'Engineers', 'Digitizer', 'Source Supplier', 'Software Package', and 'Creation Date' fields are empty. The 'Copyright' field is filled with 'Markie Enterprises'. The 'Creation Date' field is filled with '01/01/2004'. The 'Fill \* fields automatically' checkbox is unchecked. The 'Comments' text area contains the text 'Comments Field for any other information'. The 'Subject' text area is empty. The 'OK', 'Cancel', and 'Help' buttons are visible at the bottom right.

## Display name

The displayed name defaults to the Display Title field shown in the dialog above, if this is not found embedded in the Wave file then the disc filename is used.

This text can be edited to something more applicable using the highlighted edit box below.

Comments:-  
 Comments Field for any other information

Display Name:-  
 1KHz Sinewave Tone

If a number of button names require editing then the [Track Names](#) menu option is more appropriate.

## Font/Colors

The second tab shows the button and allows the font name, style and size to be set for each of the three items - track name, button number and time remaining. The font edit page can be selected via the tabs or by clicking the text in the button.

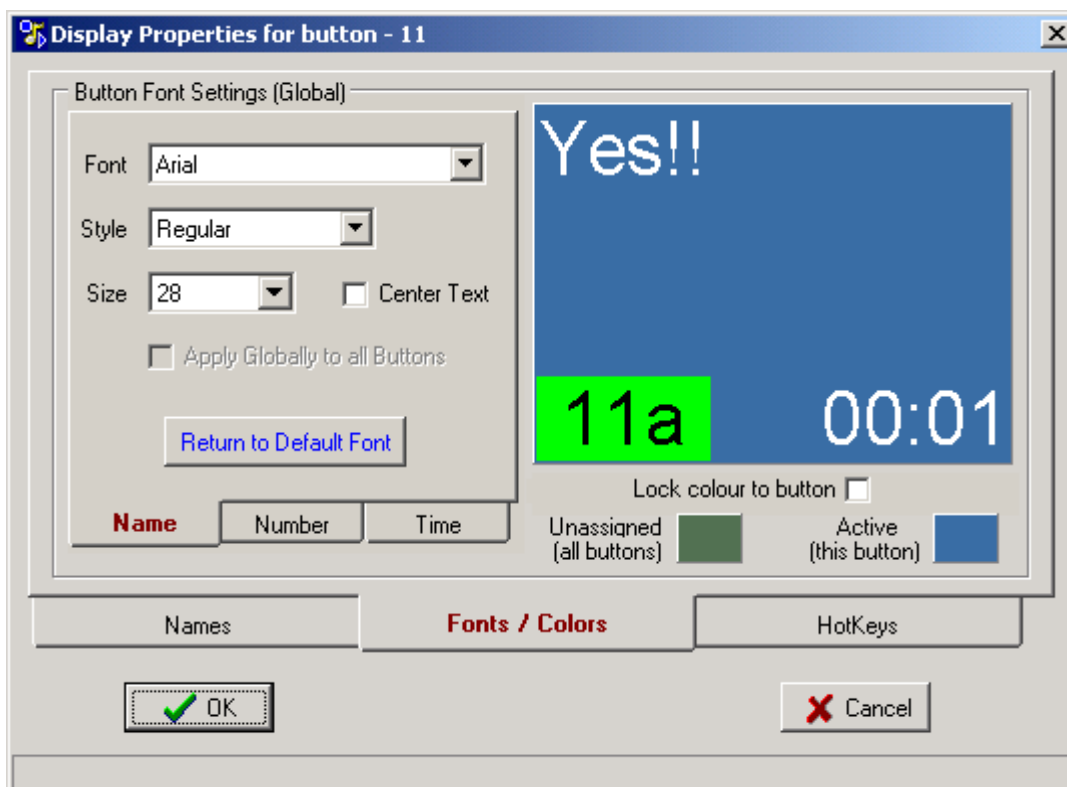

The fonts are set to AutoSize so that when the button size/aspect ratio changes the text stays approximately in the same proportion to the button. As a result of this bit mapped fonts should be avoided as they do not scale correctly.

When setting the font sizes remember that in certain circumstances the time remaining text in the lower right corner can have an additional two leading characters "X@" (track trimmed and speed changed).

In the example below buttons 42..45 currently use the same font for the trackname - the default font Arial 24pt.

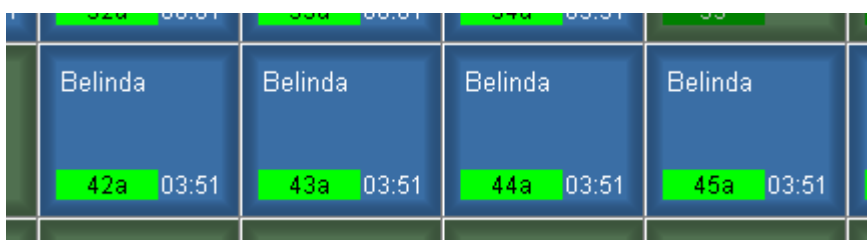

In the [Options|Display](#) menu there is an option "Individual Button Fonts" to set the trackname fonts independently, when this option is selected the "Apply Globally to all Buttons" on the Display properties page is enabled.

By unchecking "Apply Globally to all Buttons" option the trackname font can be set for this button only - here set to Arial 28 pt.

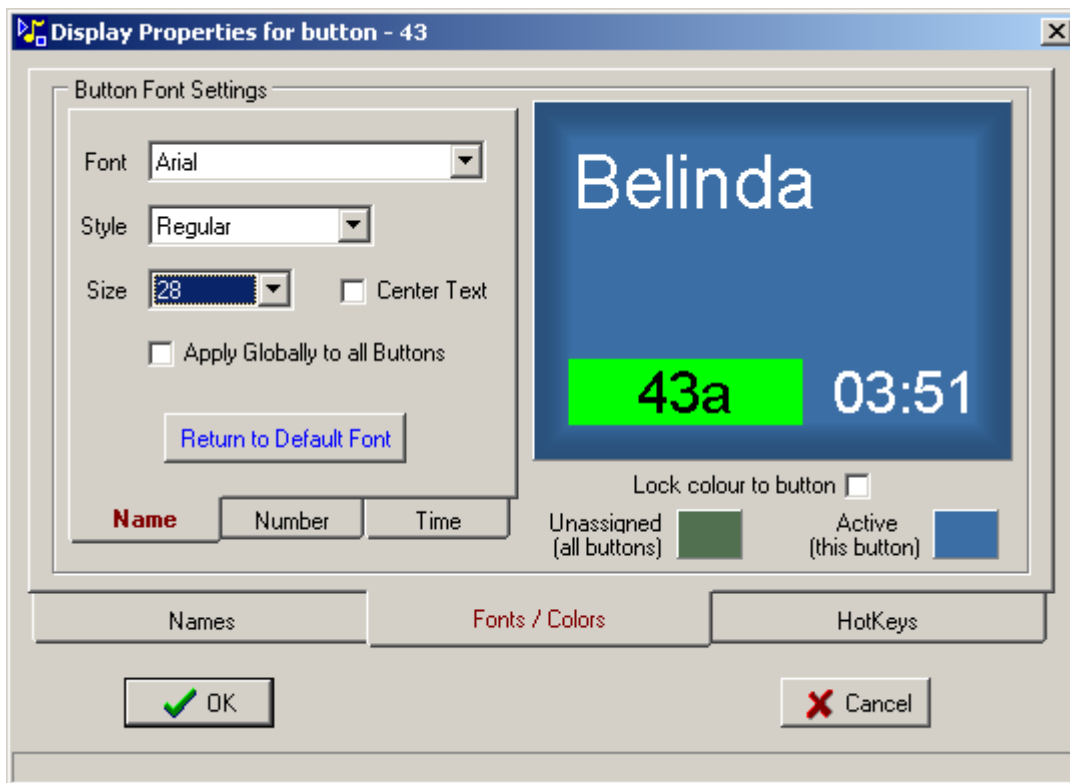

If button 44 is set to Arial 36 pt and button 45 set to Arial 36 pt italic the buttons will look as below, the individual fonts are saved in the Session files.

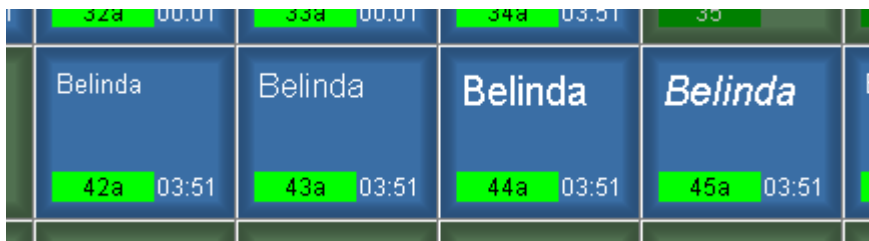

The Return to Default Font button does just that.

To change the background colour of the button right click the Active colour panel for a popup menu

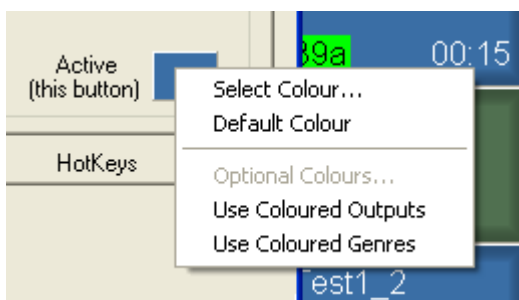

Choosing Select Colour displays a full colour selector dialog

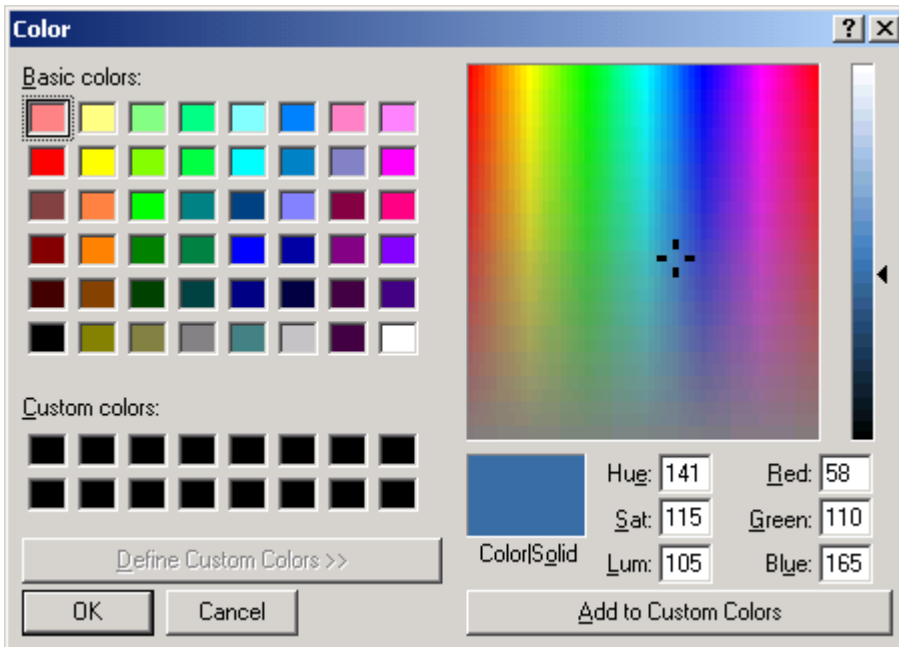

Similarly right-clicking the unassigned colour panel brings up a similar list of options

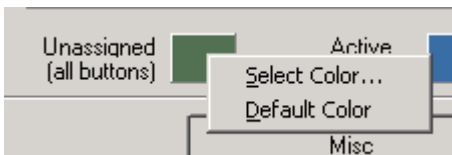

The colour of the button may be locked by checking the box below to avoid it being changed when the audio track is replaced

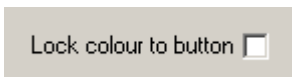

Right-clicking the button display will list a number of options



Button Colour - is an alternative route to the colour selection described above

Button Image - allows the file that is to supply the button image to be defined, at present the image types are restricted to Bitmap (\*.bmp) and JPEG (\*.jpg) with an uncompressed size less than 2.5MB

A selection of sample images can be found in the ..\Program Files\Serialtech\SpotOn\Bmps folder.

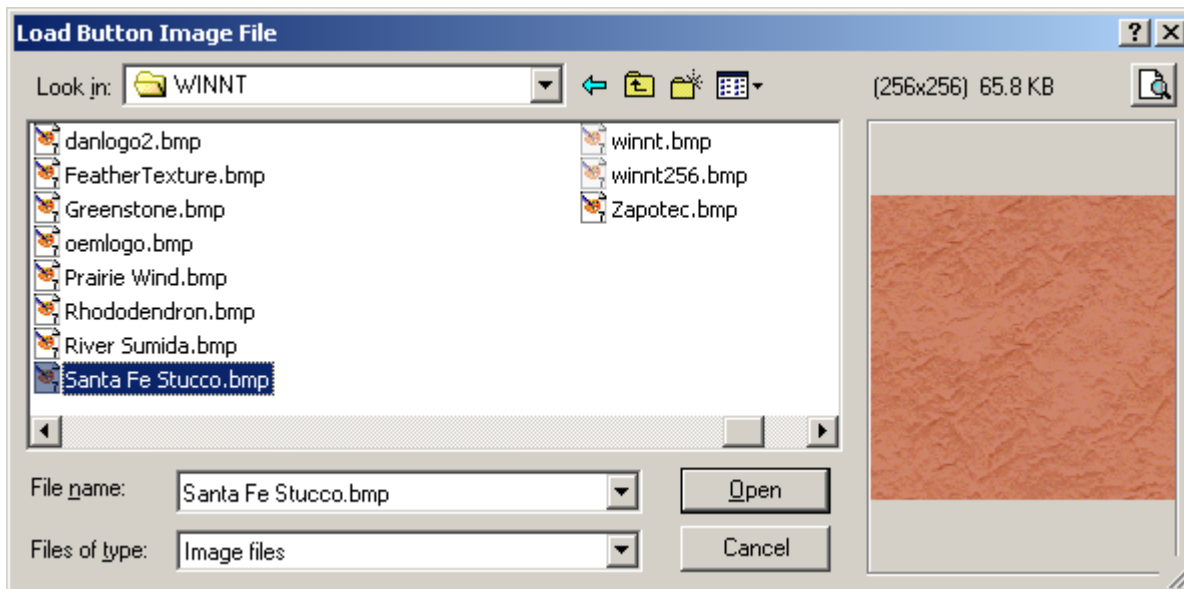

If an image file is already defined then clicking on Cancel in the file selection dialog will display an option to clear the image from the button.

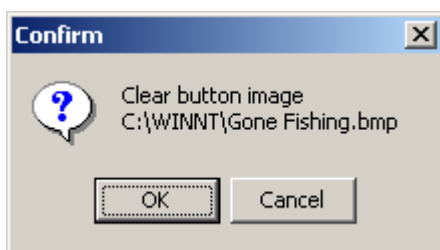

All button Images can be cleared via Global|Clear Button Images

If the menu item [AutoLoad Button Images](#) is checked then a dialog offering the option to associate the image with the button audio file is displayed, clicking OK will then set SpotOn to automatically load the same image each time that specific audio file is loaded.

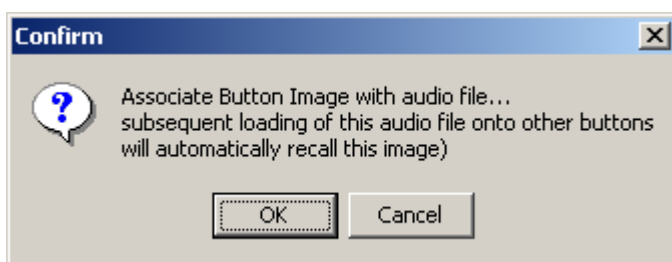

Assigning a bitmap to button will result in a Properties display as below, note the Trackname text is white, the text can be either white or black the selection is normally made automatically dependent on the button colour to make sure the text is always readable.

When a bitmap is used as a background for a button the automatic choice of white or black text becomes very difficult, so the user can force the text colour by changing the basic button colour.



Selecting a white button background will give black text and similarly selecting a black button background gives white text, the image below shows the result of selection the button colour to white.



The button background colour used on button with bitmap images is independent of the original plain button colour.

## Output Colours

As well as colouring buttons on a per button basis it is also possible to colour the buttons on a per output basis, so all buttons on output 'a' would be one colour and all buttons on output 'b' another colour and so on.

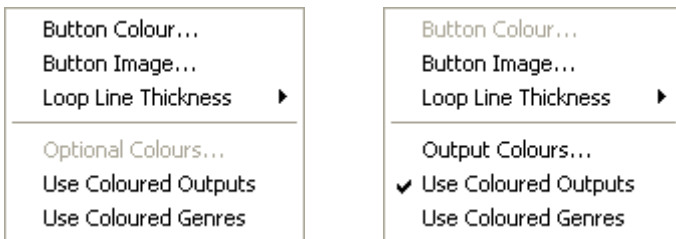

Selecting 'Use Output Colours' enables the 'Output Colours' option and when clicked opens up a further dialog window.

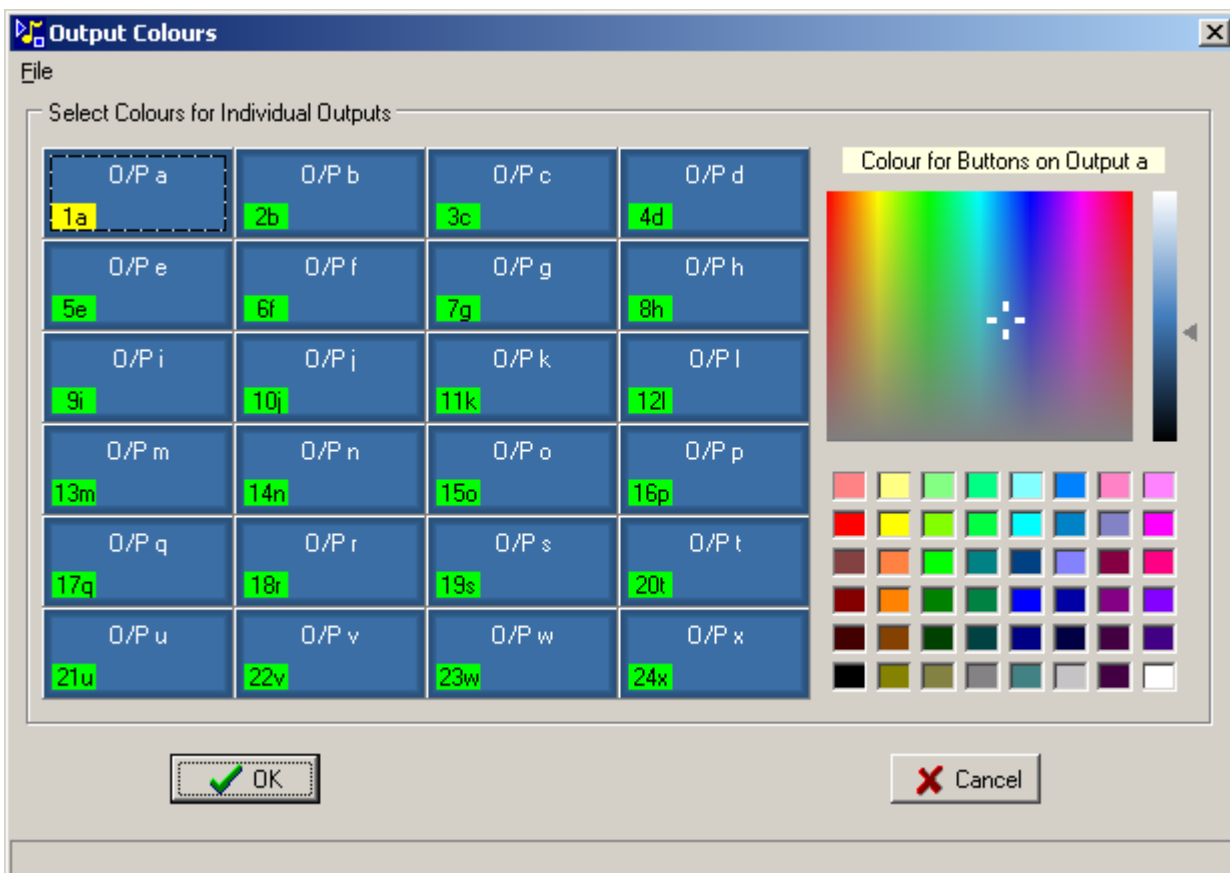

Select an output from the grid of buttons on the left and then paint a colour from the selectors on the right of the window.

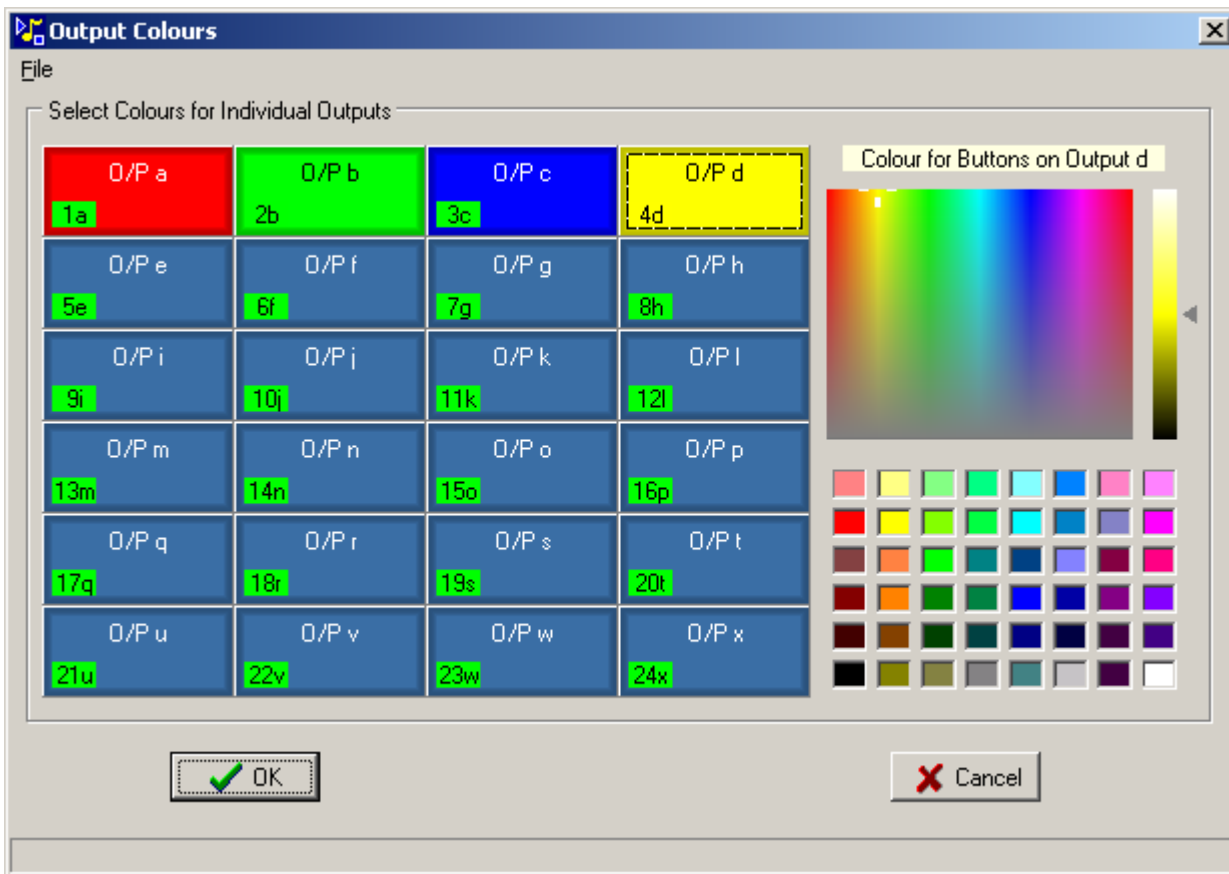

The option to colour buttons based on their genre is available by checking Use Coloured Genres, by default the genre is defined as a numeric 1..24 in the Originator Reference field of BWAV metadata.



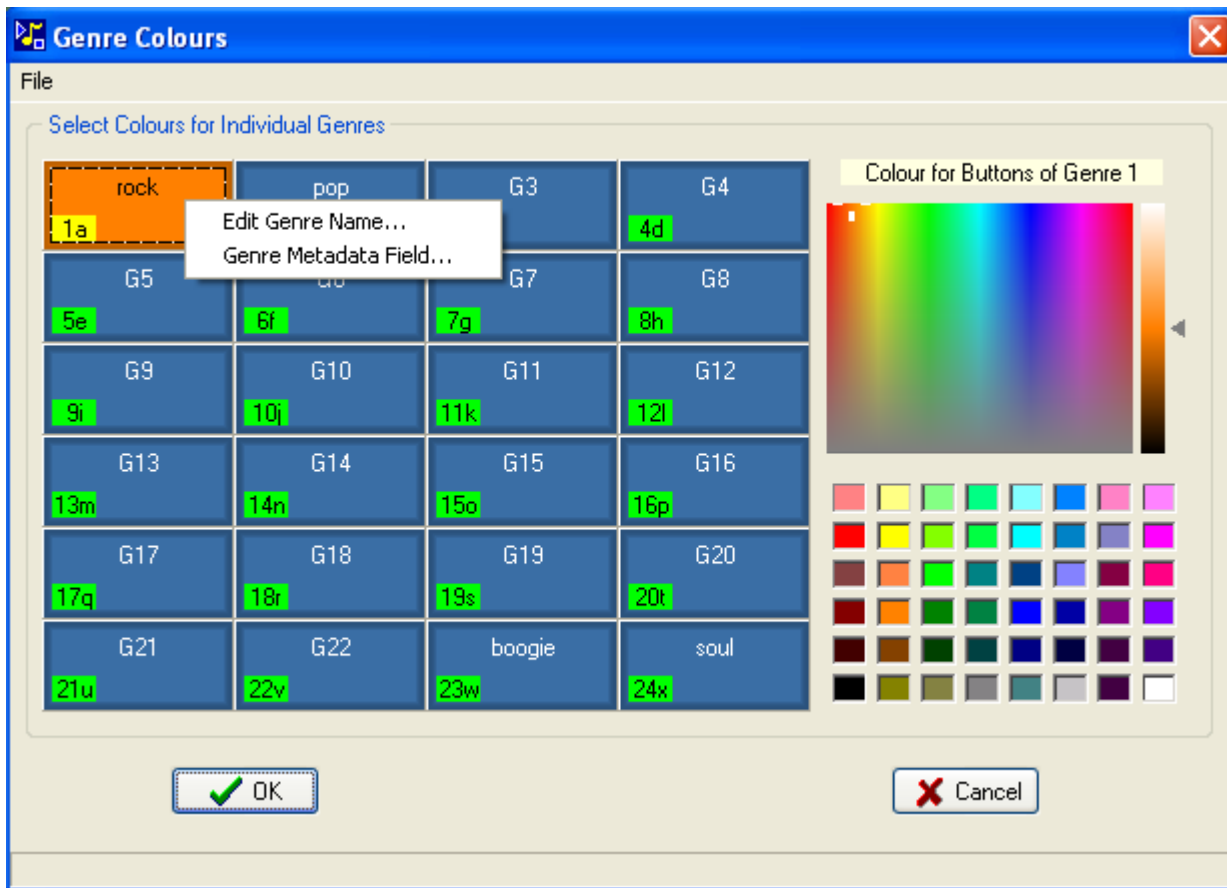

Right-clicking any of the Genre buttons will allow the genre names to be edited.

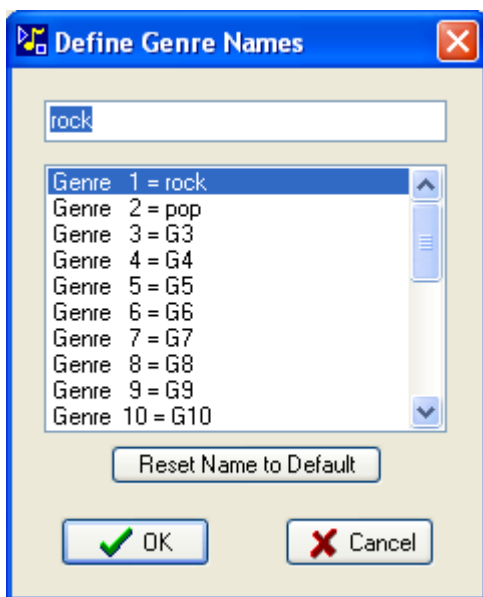

The default metadata field for the Genre number is the Originator Reference field of BWAV metadata, the field can be changed via Genre Metadata Field in the popup menu

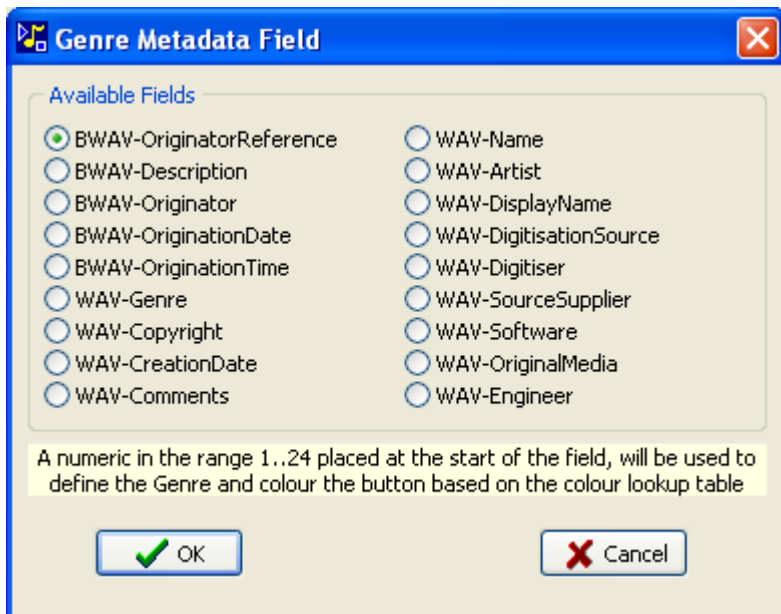

With Use Coloured Genres checked, the button colours are fixed and by the assigned genre/colour mapping, if the individual button colours need to be changed from the fixed genre colours then deselecting the Use Coloured Genres option and exiting the Properties dialog will show the dialog box below.



Selecting Yes will preset the button colours from the genre colours and then allow individual button colours to be changed. Selecting No will cause the buttons to revert to their original colours.

The set of output colours is saved in the session files along with the 'Use Coloured Outputs/Genres' option.

The File menu allows the colour template to be saved and recalled from disc

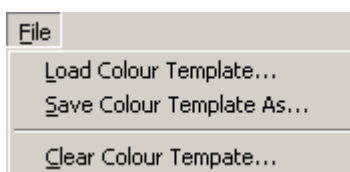

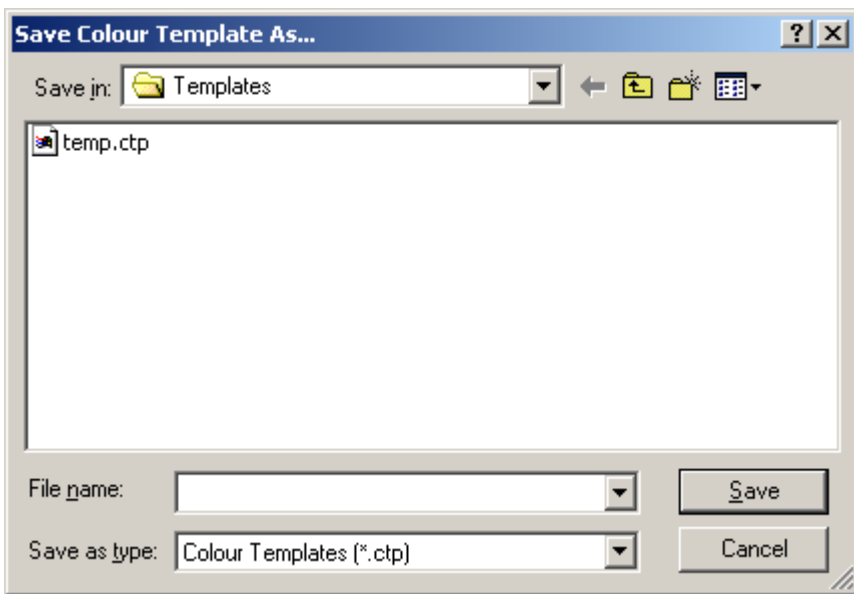
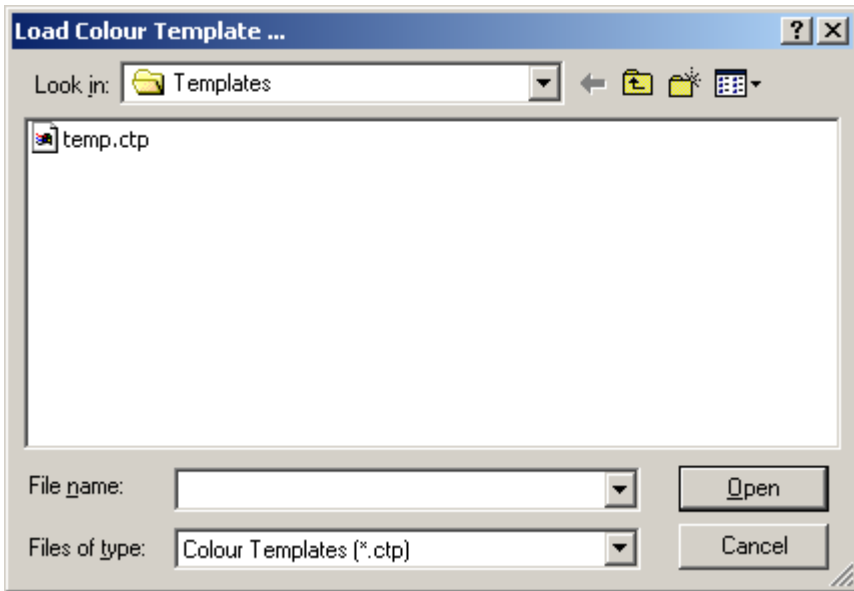

Also the colour template can be reset to the default colours

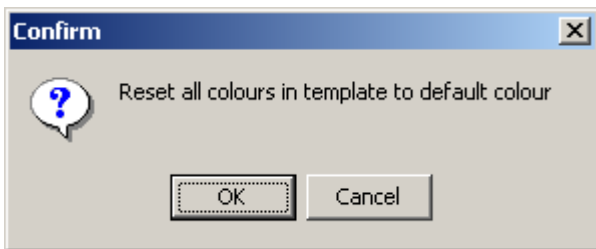

Loop Line Thickness - changes the thickness of the ellipse drawn on the button to indicate looped tracks, the value range is 1..4 with the default value being 1

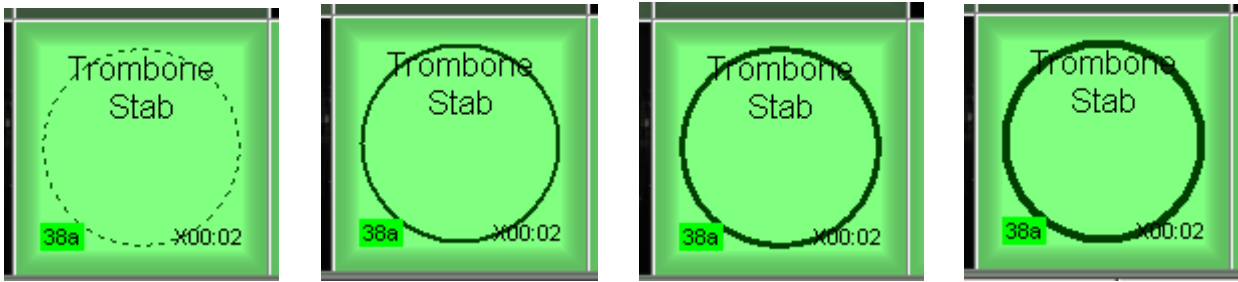

## HotKeys

HotKeys can be freely assigned to buttons, the HotKeys available are restricted to F1..F12 and A..Z, along with the numeric pad numerals (assuming keyboard Num Lock is active). The HotKeys are not case sensitive and display in uppercase.

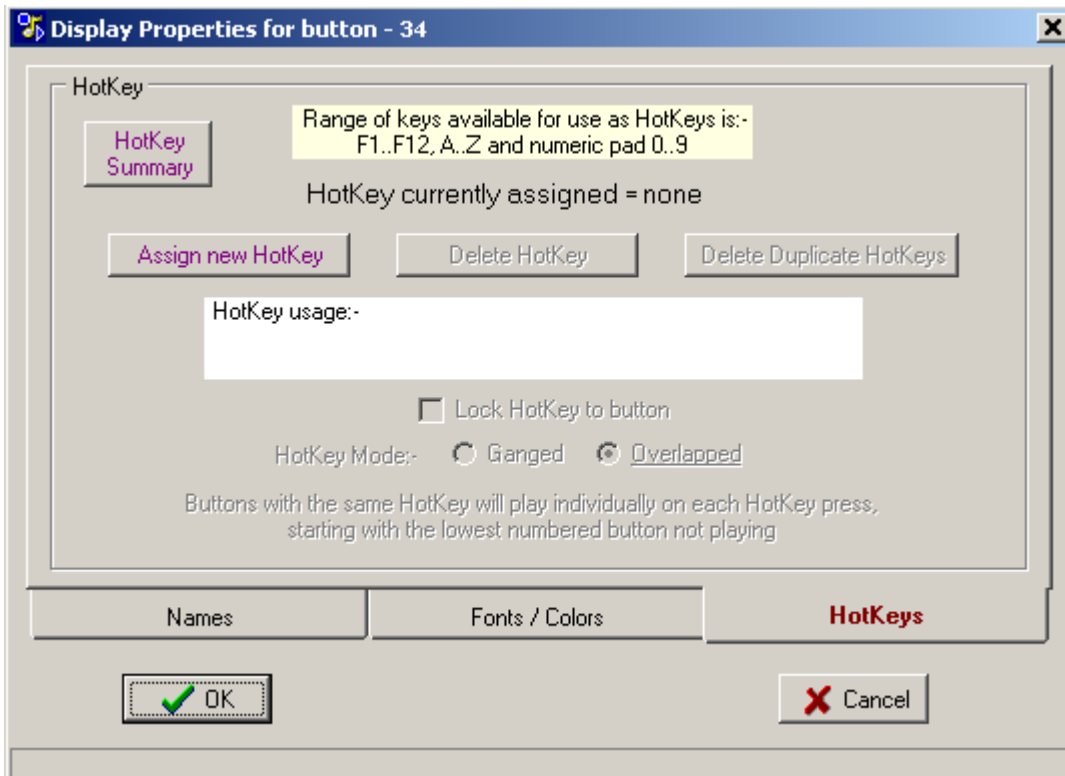

Click the Assign new HotKey button which brings up a further dialog box.

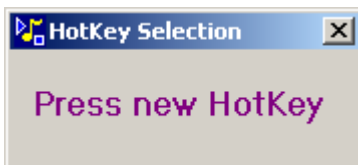

Note: the keyboard shortcut of Ctrl+right click will also bring up the HotKey selector from the main window, it will be positioned over the appropriate button and accept valid HotKeys or the Del (delete) key as an input. When assigning HotKeys with this method duplicate HotKeys are automatically deleted unless they are locked to a button.

Press the key required as the HotKey, if 'd' was hit the display will show that as the selected key (display is in uppercase)

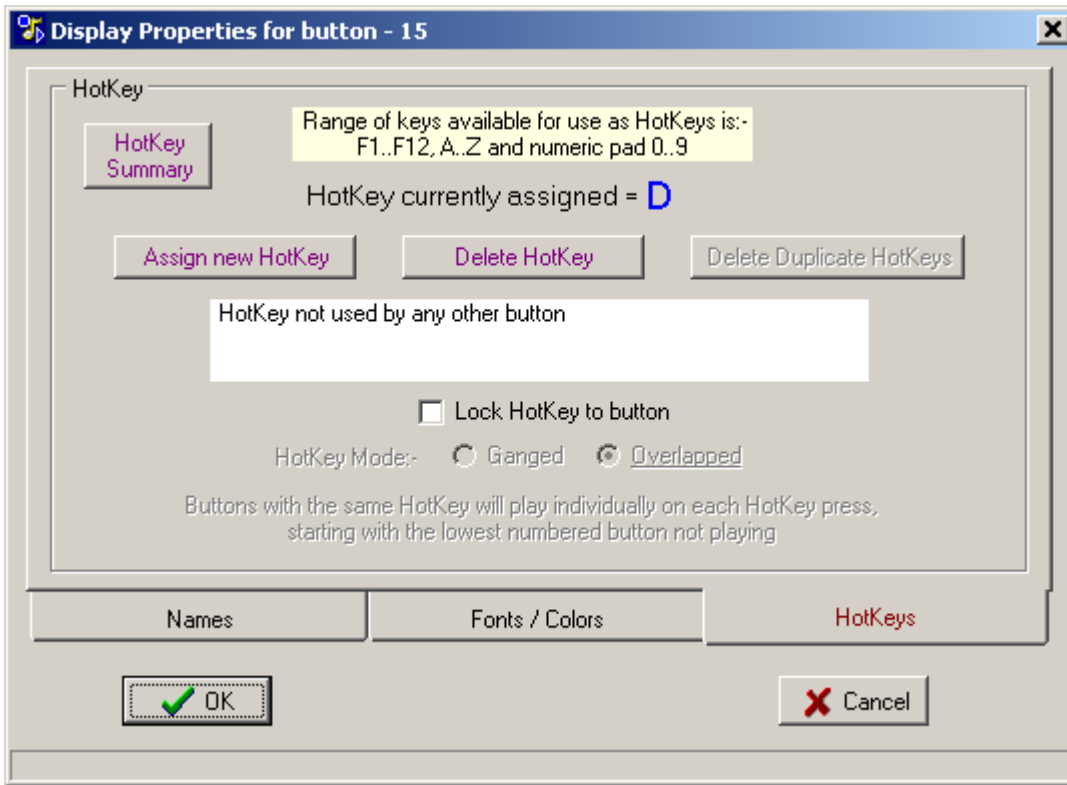

HotKey selection can be deleted using the Delete HotKey button

If other buttons also have the same HotKey then they will be listed, below button 33 is shown to also be assigned the "D" HotKey

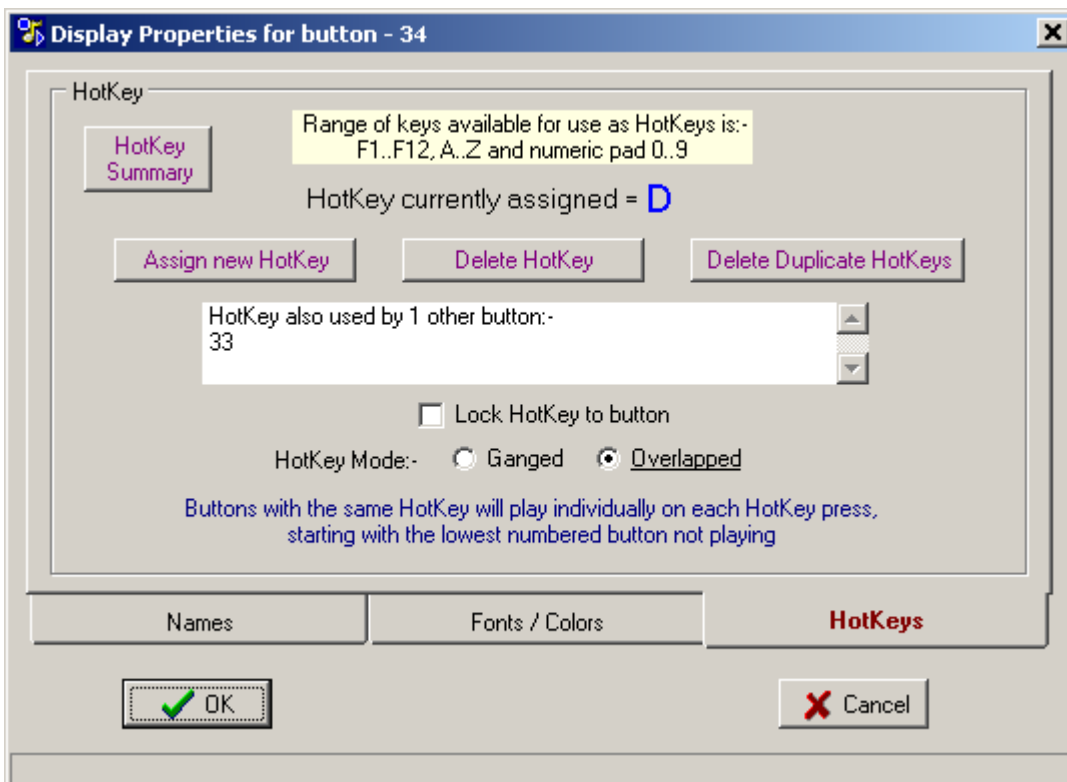

Any other buttons that have the same HotKey can have their non-locked HotKeys assignment deleted by clicking the "Delete Duplicate HotKey" button as shown below

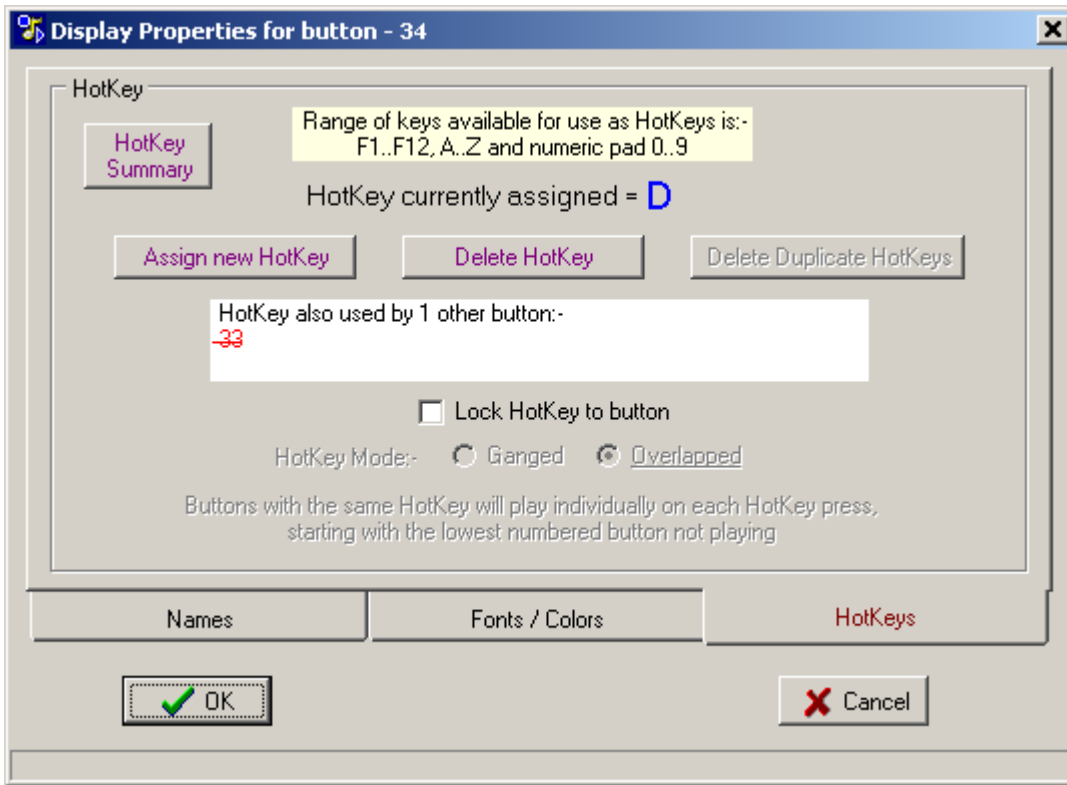

If Hotkey Paged mode is selected then the list of buttons using the same hotkey will be modified to show button numbers on other pages in brackets eg 34,35,[12],[124], in addition a 'L' suffix will be added to the number if it has the HotKey locked to the button.

The HotKey can be locked to the button so that if the button is loaded with a new track - directly or via pasting - the HotKey selection remains.



When more than one button is assigned to the same hotkey as in the example above there are two modes of behaviour - Ganged and Overlapped, see [Advanced Operation](#) for further details

Click the appropriate button to toggle between Ganged and Overlapped modes

In order to select a hotkey it may be useful to see the hotkey allocation across all buttons, the HotKey Summary button will show the hotkeys sorted in Alphabetical, Qwerty or Numeric sequence.



The image shows a dialog box titled "HotKey Summary" with three tabs: "Alphabetical", "Qwerty", and "Numeric". The "Alphabetical" tab is selected. Below the tabs is a table with four columns: "Key", "Btn", "GPI", and "Track Name". The table contains the following data:

Key	Btn	GPI	Track Name
A			
B			
C			
D			
E			
F			
G			
H	15		1kHz_16_44_AB_M8
H	18		1kHz_16_44_AB_M8
H	19		1kHz_16_44_AB_M8
I			
J	17	Yes	Walk On 5 Extra 1-5
K	27	Yes	Belinda - Heaven - Guide
K	31	Yes	AudioTrack 05 Go Go no bungalow
K	320	Yes	Trombone Stab
L			

If the HotKeys are currently disabled then the message below will be shown at the bottom of the dialog box.

HotKeys  
Disabled

### Misc

All HotKeys can be deleted from the [Global](#) main menu item

HotKeys can be enabled/disabled globally via the [Options](#) main menu item

# Audio SetUp

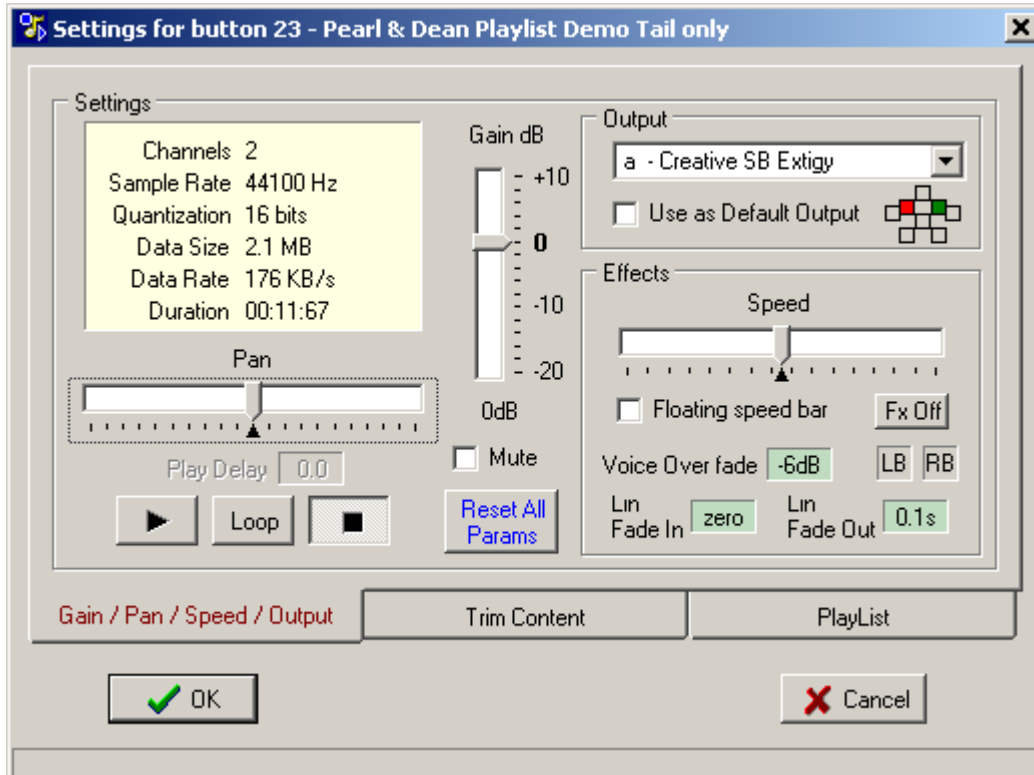

This section provides a way of controlling the way the track is played out and is split into three tabbed pages - Gain, Trim and Playlist

[Gain/Pan/Speed/Output](#)

[Trim](#)

[PlayList](#)

# Audio SetUp - Gain

## Gain/Pan/Speed/Output

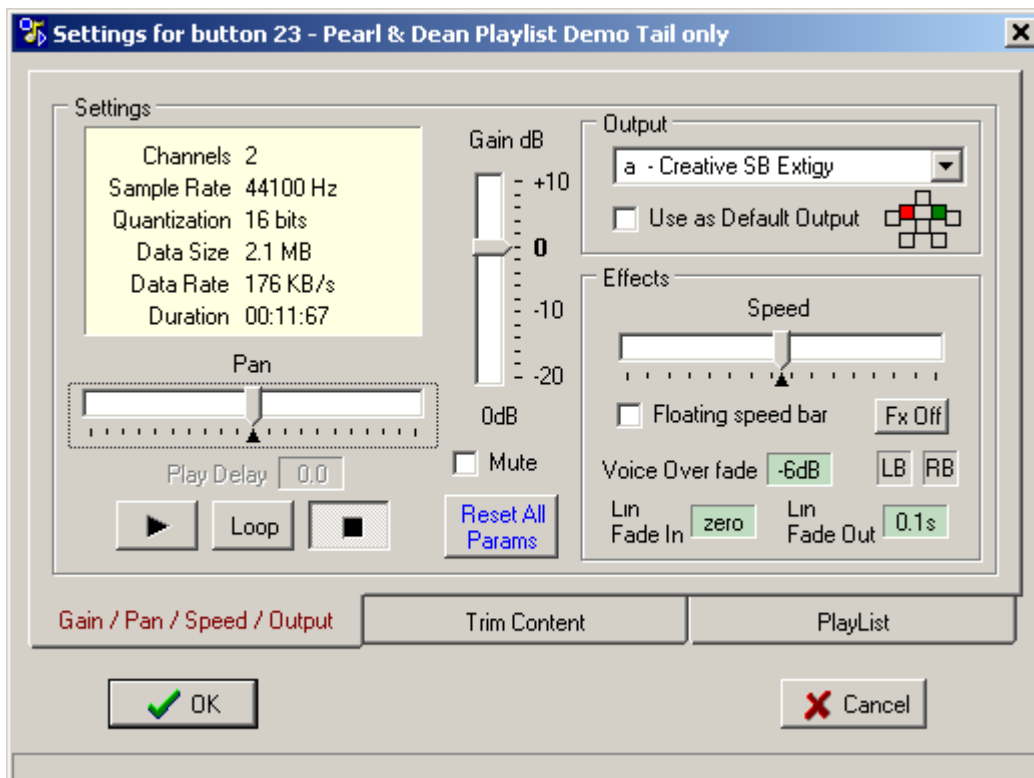

The first tab shows the details of the track in the information panel and which audio output port will be used for playback

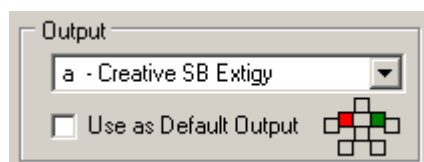
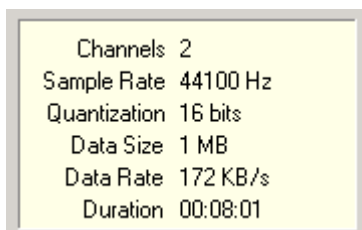

Checking the Use as Default Output Device checkbox will set all subsequently loaded buttons to play out from this output, the default output is the Windows Primary Sound Driver. See below for information about setting the [Preferred Driver](#)

The set of coloured boxes to the right of the checkbox indicates/controls the positioning of the audio channels in a multichannel environment.

The basic parameters of Pan, Gain and Speed (25%..400%) can be set along with the fade in and out times. Clicking on the parameter zero markers or double-clicking the parameter title will return the value to default setting.

[MetaData](#) can be embedded within audio files, SpotOn can decode BWAV and iXML data, if a track contains either of these formats of metadata it will be shown along side the number of channels in the summary panel.

Channels 1 (B'WF,XML)  
Sample Rate 48000 Hz  
Quantization 16 bits  
Data Size 210 KB  
Data Rate 96.0 KB/s  
Duration 00:02:14

### Output

The required output is selected from a drop down list

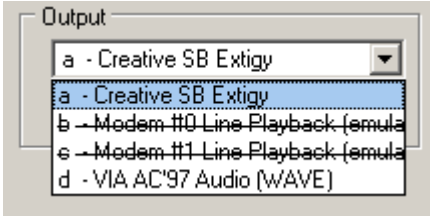

Here the entries for outputs 'b' and 'c' are unavailable as they are not real audio output devices.

Selecting output 'd' will change the display to that shown below

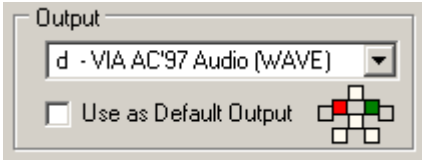

If any output devices have been masked out they will appear in red text, this would be the case when there are spare real outputs that are not to be used, for instance an on-board sound card is most likely to be masked.

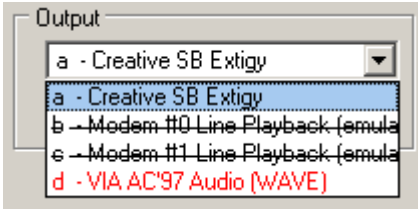

Masked outputs cannot be selected, the masking is set up via the [Output Device Assign](#) dialog.

If the track is playing when the output selection is changed the prompt box shown below will appear

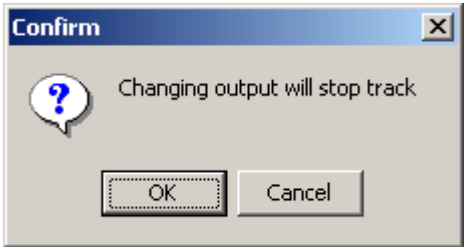

An alternative way to assign the output device is to shift+ctrl right-click a button, this will display the Group/Output selection popup menu

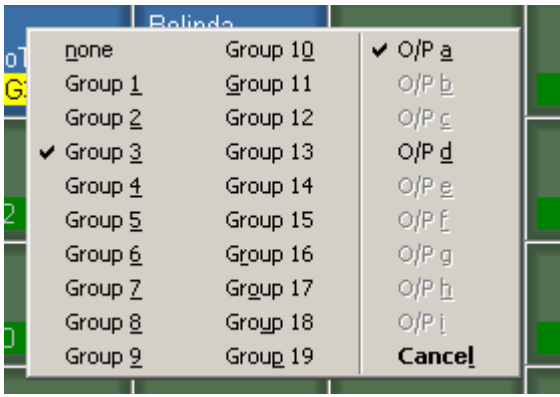

The outputs can be assigned by checking the appropriate device on the right hand side of the menu.

## Gain

The range of gain can be changed via the Options|Gain Offset main menu item between [+10dB..-20dB] and [0dB..-30dB]

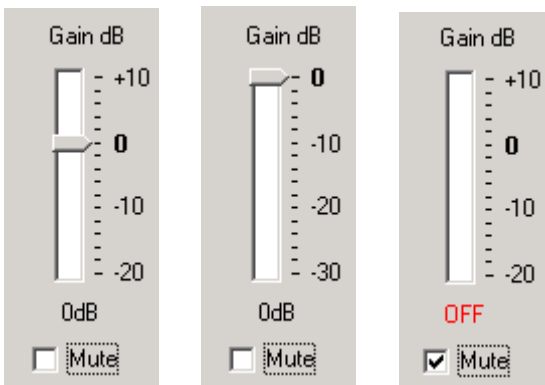
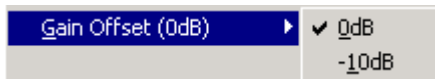

As shown above right the track can also be muted, this is achieved by right-clicking anywhere on the gain track bar and choosing Mute, UnMuting the track will return it to the original gain setting.

The muted track is indicated on the button by a line through the duration label



There is an option to view a wider gain range of 60dB, right-click the gain slider and check Coarse Gain, the gain display labels will change colour to purple.

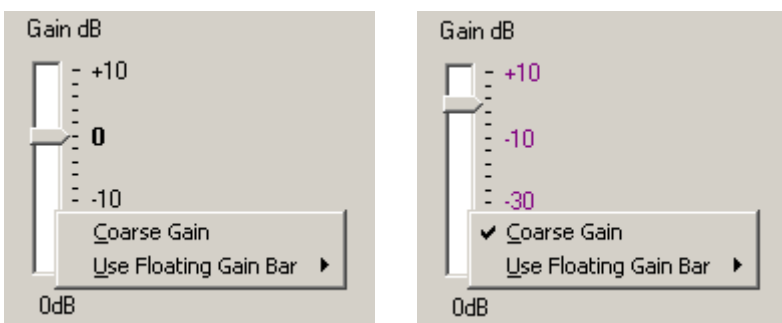

If "Replay Gain" Metadata is present in the audio file it will be shown in this popup, clicking on Apply Replay Gain option will set the gain level accordingly - in this example to -6 dB.

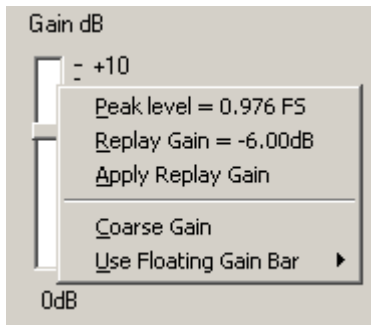

Replay Gain is calculated to bring all track levels to the same loudness, the value is derived from psychoacoustic algorithm used to scan the track.

Also in this right click menu is an option to use a Floating Gain Bar

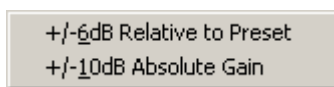

the Gain Bar has two scaling options:-

a, +/- 6dB relative to the preset gain bar

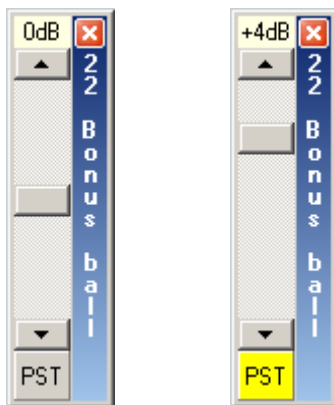

This floating gain bar allows trimming (+/-6dB) of the preset gain, the PST (preset) button at the bottom of the window will be active and coloured yellow when the gain has been moved away from the preset value, clicking the PST button will return the gain to the preset value.

b, -10dB..+10dB as absolute gain, effectively mimicking the top part of the preset gain bar

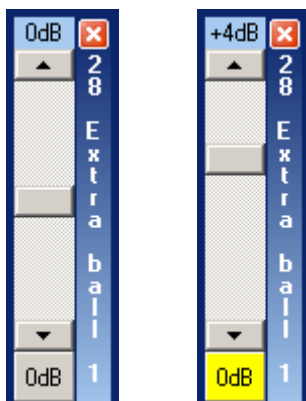

This floating gain bar allows absolute gain adjustment between -10dB..+10dB, the 0dB button at the bottom of the window will be active and coloured yellow when the gain has been moved away from the 0dB value, clicking the button will restore the gain to 0dB.

To distinguish between the two modes the top panel of the window is coloured yellow for +/-6dB relative and blue for -10dB..+10dB absolute.

The absolute gain setting is shown at the top of the window, upto four floating gain bars can be displayed simultaneously

## Pan

The pan control can be moved left and right to position the audio within the stereo image, with a 6 channel 5.1 surround sound file loaded the pan control will rotate the whole sound image clockwise or anticlockwise as the Pan control is moved left and right respectively. With all other multichannel files the pan control is [disabled](#).

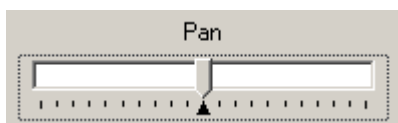

AutoPan is a feature that allows the playing of one button (master) to modify the pan setting of another (slave) these Pan Masters and Slaves are setup in the [Master/Slave](#) links dialog.

A button must be set as a [Pan Slave](#) before the stages below can be completed.

As an example, move the pan control to the half right position

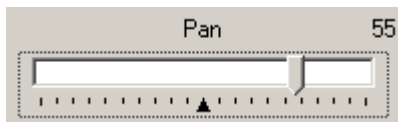

right-click the pan control slider

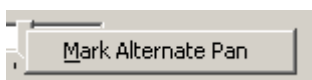

click on Mark Alternate Pan, this will then mark the position with a red pointer on the top of the pan control



now move the Pan control to full left



For 1 and 2 channel files the Pan value is show in percent left or right (0..100), with surround sound files the value is 0..180 indicating the angle of rotation.

Now there are the normal Pan setting of full left and an alternate setting of half right, the AutoPan feature will change the pan settings as follows:-

- |                                 |  |
|---------------------------------|--|
| 1, Start of Pan Master fade in  | Slave Pan starts to change from full left towards half right |
| 2, End of Pan Master fade in    | Slave Pan now half right                                     |
| 3, Start of Pan Master fade out | Slave Pan starts to change from half right back to full left |
| 4, End of Pan Master fade out   | Slave Pan now full left                                      |

The profile of the Pan change is independent of the fade law selected on the master button.

## Speed

The speed of an audio track can be varied between 25% and 400% of the original value providing the sound card can handle this range.



The speed value will appear in red when the sound card limits have been exceeded as shown above right.

The speed can be preset in this edit window or alternatively if speed changes are to be made live then the speed control can be displayed as a floating slide bar on the main window by checking the "Floating speed bar" box

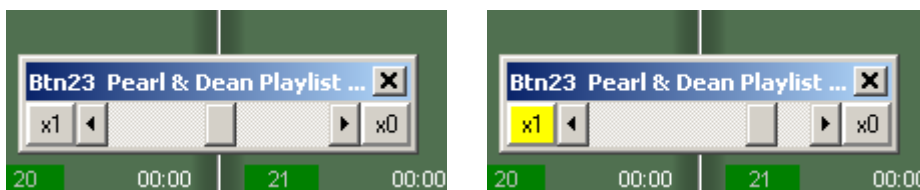
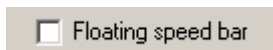

The button on the left hand side of the window is colored yellow when the speed is non-standard and when clicked will reset to x1 speed

Upto four floating speed bars can be displayed simultaneously

If the speed variation is used the the Time Remaining value on the button will be prefixed with an '@' as shown in button 61 below



The floating speed bar can also be used to automatically slowdown a track to a stop, this is controlled by the button at the right hand of the speed bar 'x0'.

The 'x0' button is enabled when the track is playing and is shown with a blue background, clicking the 'x0' button will begin the slowdown and the button colour will change to red indicating that it is active.



The 'x1' button and scrollbar tab are still active during the slow down process and will cancel the slowdown if used.

The time taken to slow down is set by a popup menu displayed by right-clicking the 'x0' button

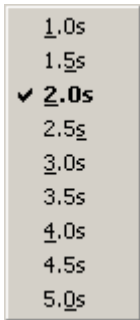

The default value is 2.0 seconds, the selected value is saved separately for each button.

## Fades



Right-clicking the Fade In or Fade Out value brings up selection of fade times from zero to 5 seconds.

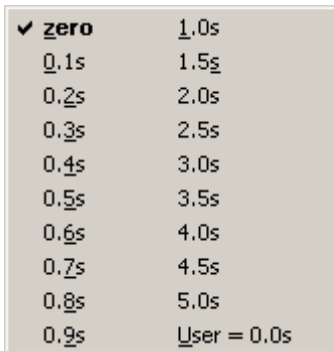

The user value can be set as described below in the Play delay section.

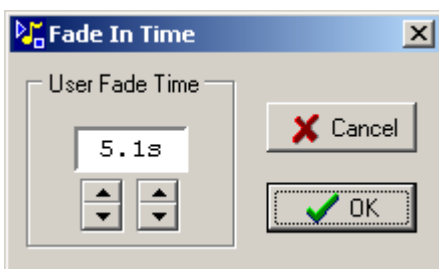

Double-clicking the fade time display recalls the default values of zero for Fade In and either zero or 100mS for Fade Out, the default Fade Out time is set via menu [Options|Default Fade Out Time](#).

Fade times can also be adjusted in the Trim window by dragging the Fade bars.



Linear and Logarithmic fade profiles are available for FadeIn and FadeOut by right-clicking the 'Lin Fade In/Out' text

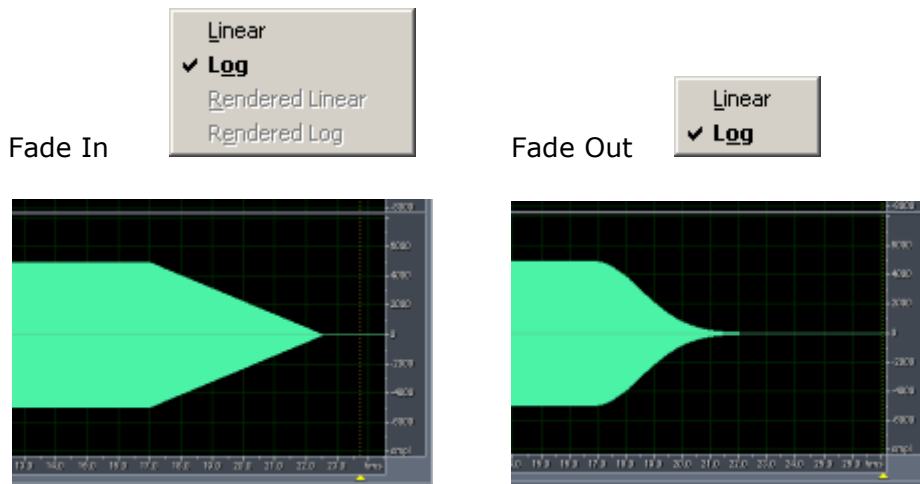

The default profile is logarithmic as shown in the right hand waveform above which has a linear vertical scale.

MicroFades are precision Fade profiles applied in real time and are consequentially smoother than the default profiles. These smooth profiles are available for all Fade Outs and Fade In durations that are less than 600mS, MicroFades are enabled globally via the [Engineering menu](#)

The MicroFades are set up as described previously but the Fade In has increased resolution, below are the Fade In popup menus for default and MicroFade modes.

<b>zero</b>	1.0s	<b>zero</b>	1.0s
<b>0.1s</b>	1.5s	<b>0.10s</b>	1.5s
0.2s	2.0s	0.20s	2.0s
0.3s	2.5s	0.30s	2.5s
0.4s	3.0s	0.40s	3.0s
0.5s	3.5s	0.50s	3.5s
0.6s	4.0s	0.60s	4.0s
0.7s	4.5s	0.7s	4.5s
0.8s	5.0s	0.8s	5.0s
0.9s	User = 0.7s	0.9s	User = 0.65s

Note on the right hand image MicroFades are enabled, the fade times are shown to 10mS resolution for times less than 700mS, the significance of 700mS is it is beyond the MicroFade limit for that track (697mS) which is 2 channel 16bit at 44.1kHz, the MicroFade limit changes depending on the track format.

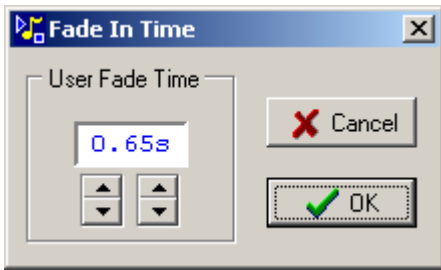

The User Fade In duration can be set to 10mS resolution, the right hand up/down button uses 10mS steps up to a duration of 1.00s then reverts to 100mS steps.



The User value editor and FadeIn/FadeOut summary panels are shown in blue text when MicroFades are selected and the duration is less than the MicroFade limit.

There is no maximum limit on the Fade out so it will apply to all values, however the Microfade out will only be rendered when the track reaches its end point, if the track is stopped prematurely then the default fade out routine will be used.

## Multi-Channel

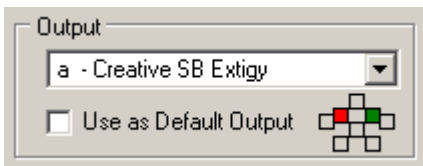

The coloured boxes above represent the 8 possible outputs for an individual audio channel

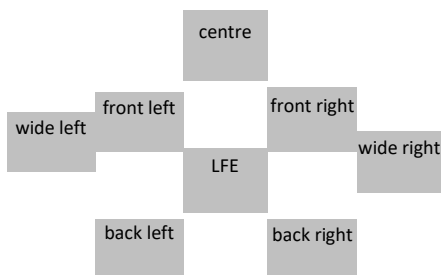

In normal non-multichannel mode the images will be:-

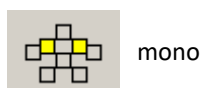

When [multichannel mode](#) is selected a right click popup menu is available.

For mono sources this will allow routing of the channel to any of the 8 possible outputs.

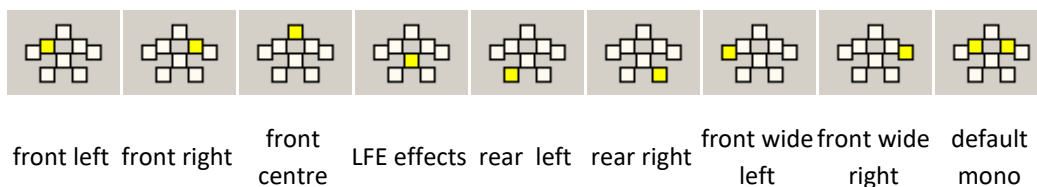

The default setting for mono sources is front left and front right

For stereo sources this will allow routing of the channels to any of the 4 possible output combinations.

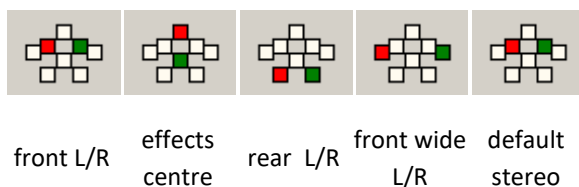
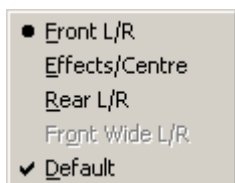

The default setting for stereo sources is front left and front right

The routing of the mono or stereo signals to different channels relies on the sound card driver being fully compatible with the Microsoft DirectSound API, some drivers including the M-Audio Delta 1010 series are not full compatible.

For Quad, 5.1 and 7.1 sources the assignments are fixed as shown below

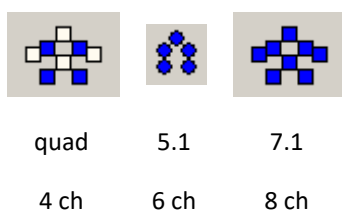

quad	5.1	7.1
4 ch	6 ch	8 ch

If the Pan control is used with a 5.1 (6 channel) file loaded the source assignments will be shown without the Lfe channel, the diagram will rotate indicating the angle of pan.

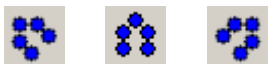

Note that Pan is only available with 1, 2 and 6 channel files, however a [6 channel file can be built](#) from a 1 or 2 channel file and loaded onto another button and then panned.

### Play Delay

Play delay is a feature that provides a variable delay time between triggering a track to play and the track starting to play.

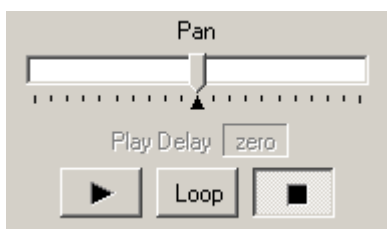

disabled

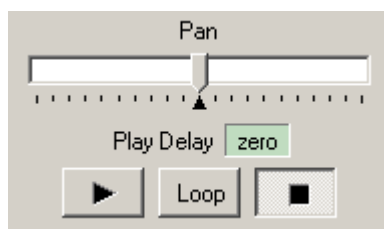

enabled

Right-clicking the delay panel shows a list of predefined delay times and a user value

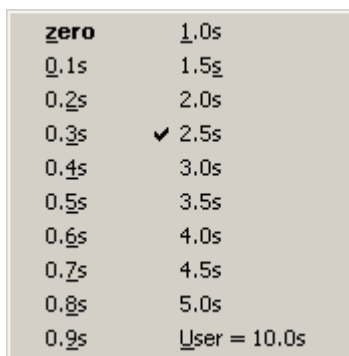
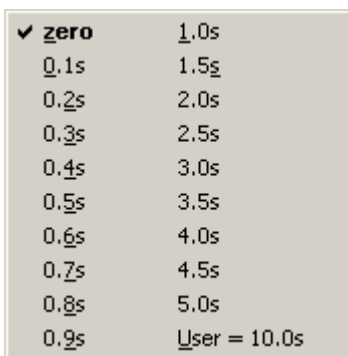

With 2.5 seconds selected the button will show two vertical lines

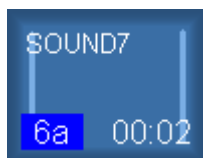
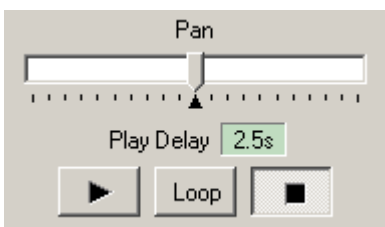

When Play Delay has been triggered the button track number will flash blue/red during the delay time before starting to Play.

The User defined setting for Play Delay can be entered by selecting the 'User' entry in the popup menu, this will show a dialog box allowing values to be set between 0.0s and 99.9s, the default value is 10.0s.

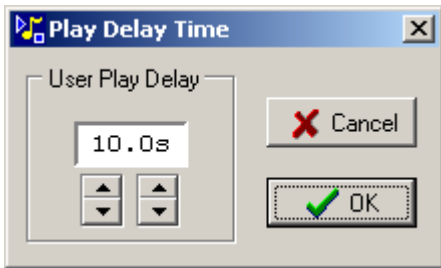

By using the up/down buttons a new value can be set

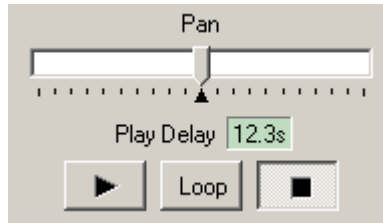
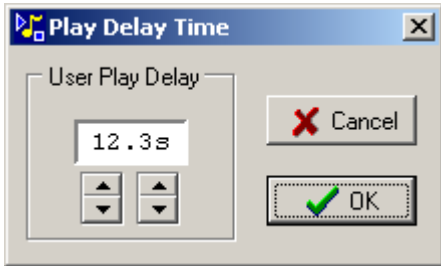

The right click popup menu will now show the new user value, which is saved separately for each button

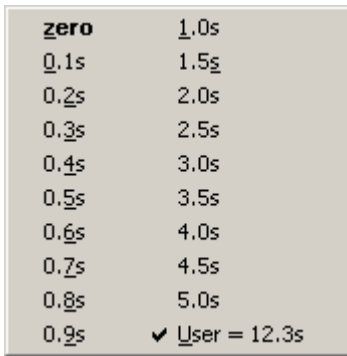

## Voice Over

Voice Over mode is a special case of Master/Slave links where the gain of the Play Slave/s is reduced or increased under control of the Master track. The amount of gain adjustment is set by Voice Over fade value shown below

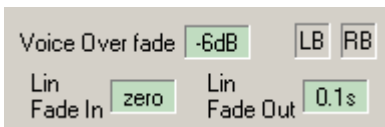

The adjustment can be selected by right-clicking on the entry panel, the default is -6dB

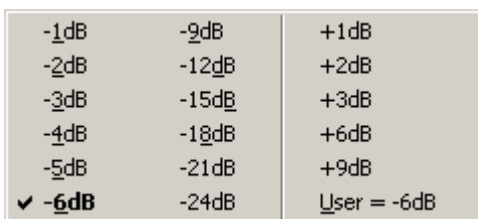

The user level can be set as described above for Play Delay

Voice over mode will only become active when selected in the [Master/Slave Links](#) dialog and the Master button has both Fade In and Fade Out non-zero.

## Channel Patching and Phase

The two panels to the right of the Voice Over fade setting control the real-time output processing of the Left and Right channels



Left-clicking the panels selects from one of four states of channel patching:-



No modification



Left channel routed to both Left and Right outputs



Right channel routed to both Left and Right outputs



With a Stereo track the Left and Right channels are summed and routed to both

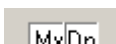

With a 6 channel (5.1) track the Left channels are summed and routed to front

Right-clicking the panels with a Stereo track loaded selects one of the four states of channel phase inversion:-



No modification



Left channel phase inverted



Right channel phase inverted

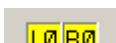

Both left and Right channels phase inverted

Channel patching and phase inversion functions cannot both be used at the same time.

## Button Effects

An audio effect can be applied to the track, the effect can be either Echo, Flange, Reverberation or Gargle, the button on the right of the Effects section 'Fx Off/On' indicates whether any of the effects is active.

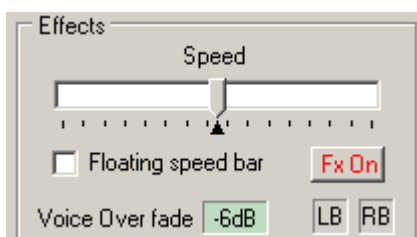
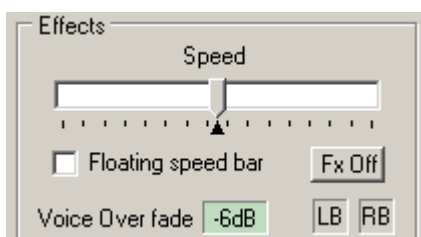

If an effect is active clicking the button will cancel the effect, if no effect is active clicking on the button will display the effect parameters

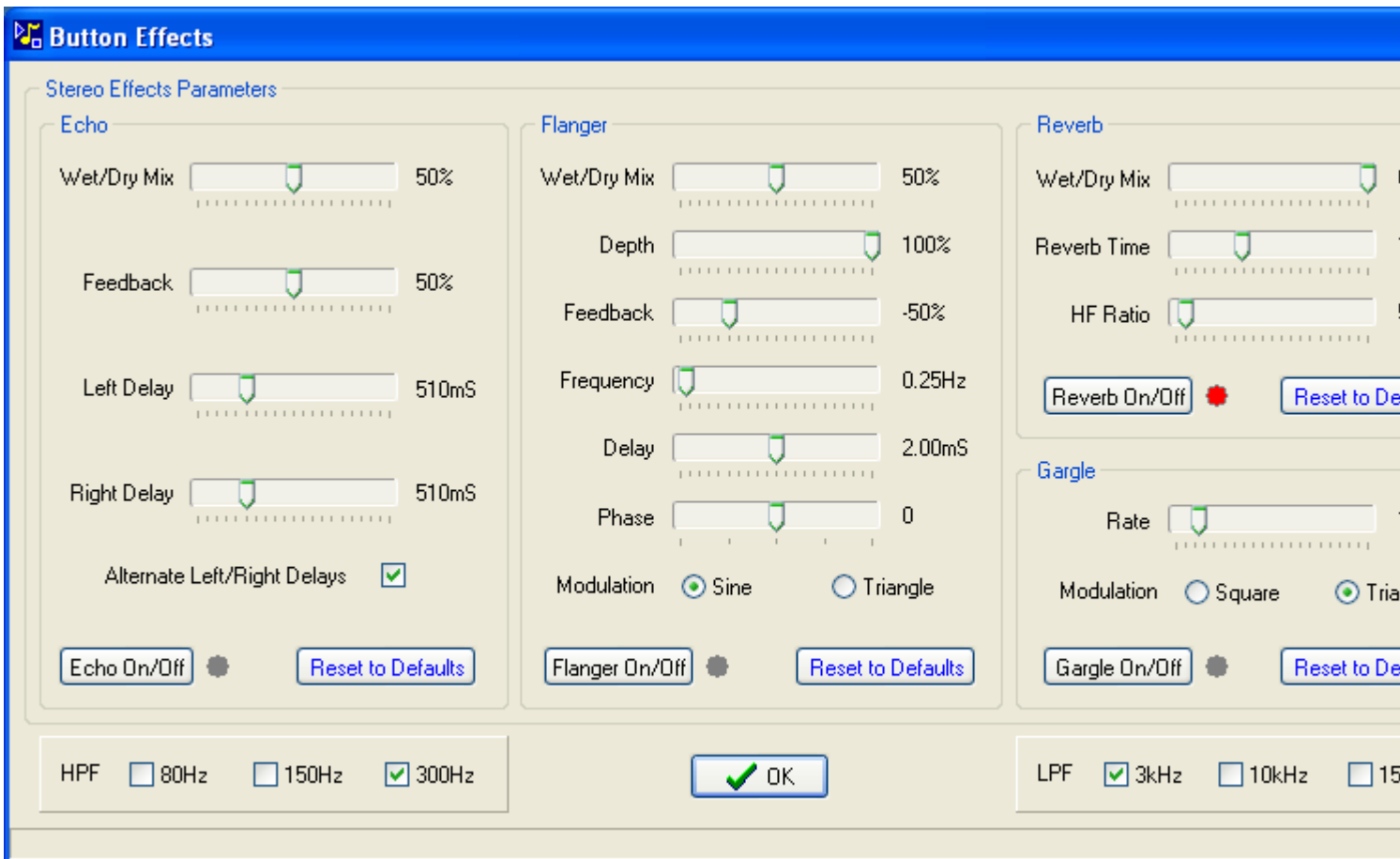

Only one effect can be active at any one time, the effects are enabled by clicking on the button in the lower left corner of the appropriate section

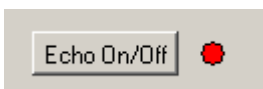

The 'LED' will show red when the effect is active.

The Effects can only be enabled/disabled when the track is stopped, so the effects On/Off buttons will automatically stop and start the track as necessary

If an effect is active the parameters can be modified live by clicking the Fx On button, this will display the Effect Parameter window shown above.

The effects are only available when SpotOn is operating in a 2 Channel Stereo mode.

The High Pass (HPF) and Low Pass (LPF) filters at the bottom of the display are live and do not require the track to be stopped to take effect.

## MetaData

If metadata is present in the audio file then right-clicking on the summary panel will display the decoded data

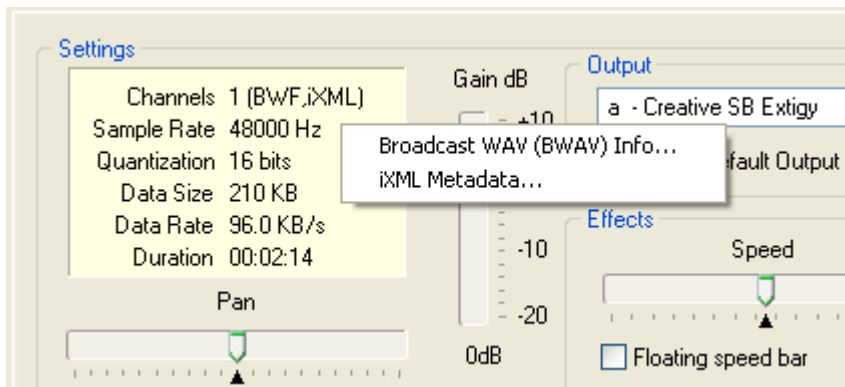

Broadcast WAV (BWA) data:-

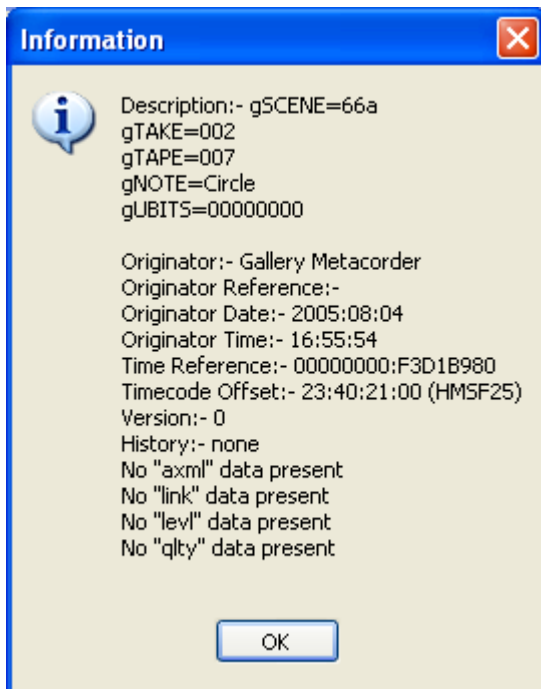

Institute of Broadcast Sound Extensible Markup Language (iXML) data:-

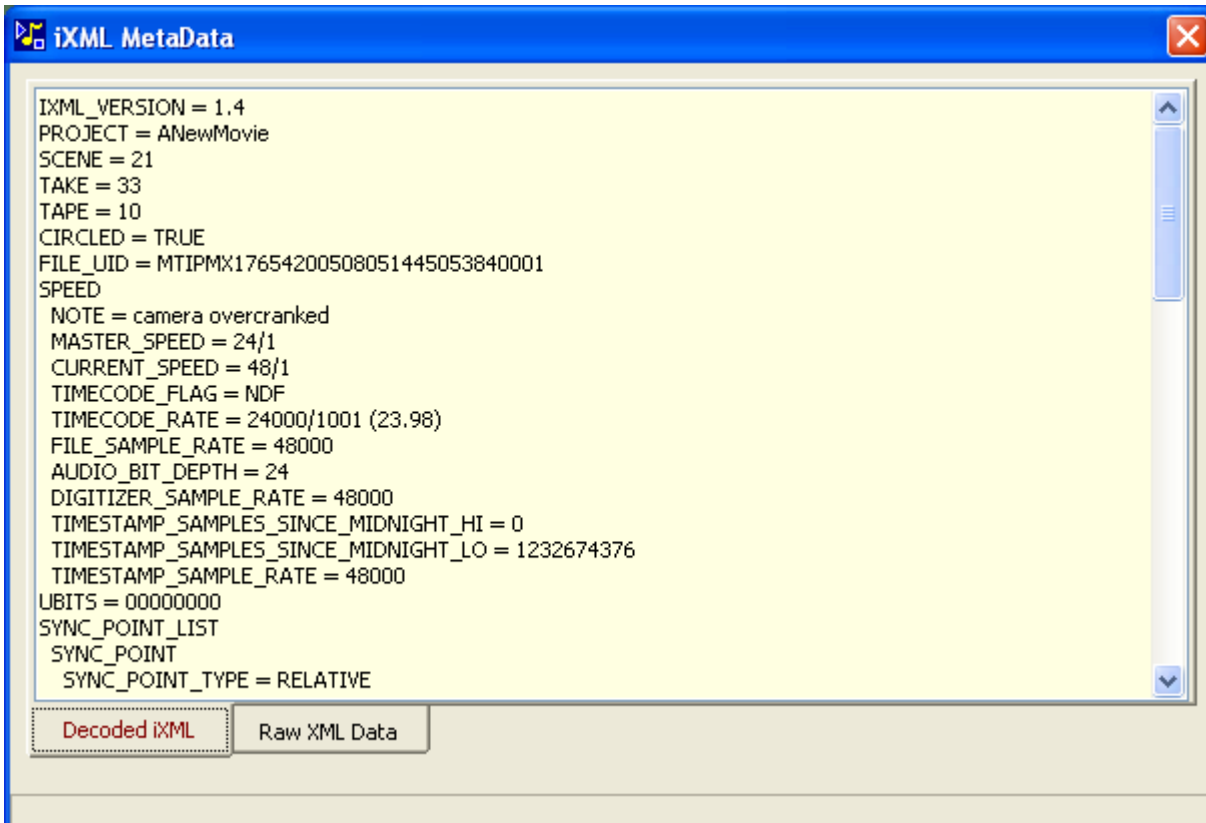

# Audio SetUp -Trim

## Trim Content

The content of the track is displayed in this tab as a time/amplitude waveform along with the trim in and out points.

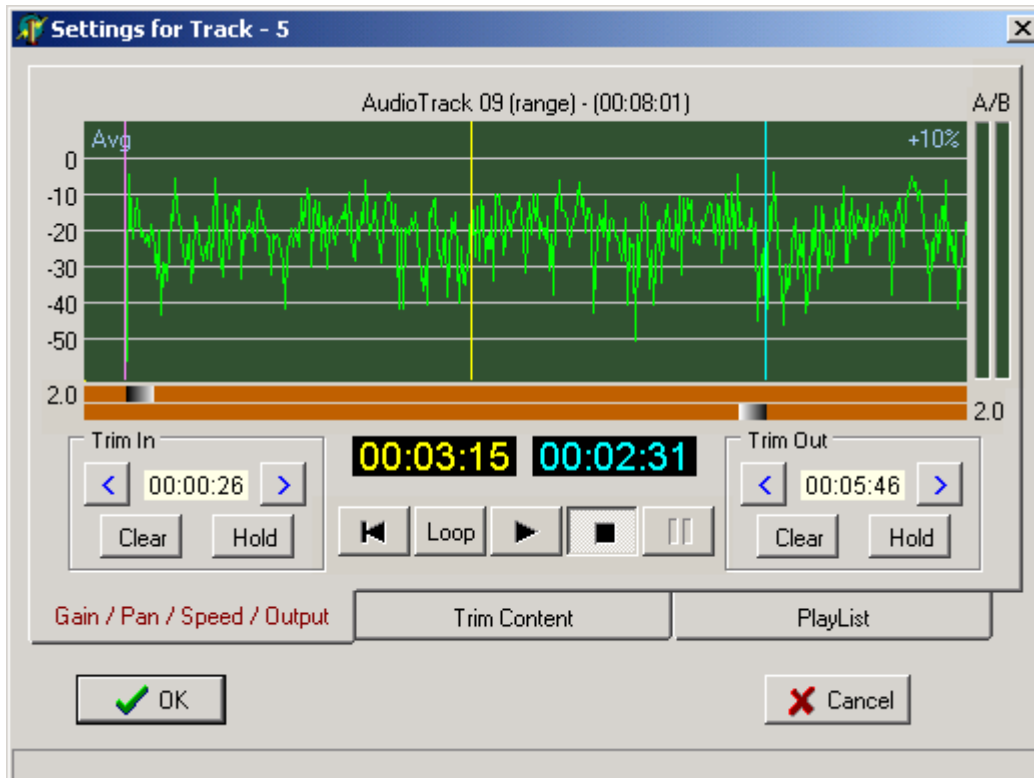

Working down from the top of the window - first is the track name and its duration in mm:ss:ff(75).

Next is the complete audio waveform shown on a -60dB..+10dB scale, the legend top left shows it is an average value plot and the legend top right shows the current speed setting.

The waveform has three vertical lines drawn across it, the magenta line marks the Trim In point, the yellow line the current position in the playout of the track and the cyan line the Trim Out point.

The function of the Trim In point is to allow the track to be played from a position other than the start of the track, here the in point is 00:00:26(75) into the track, set to eliminate the period of silence at the beginning of the track

Similarly the Trim Out point stops the playout before the end of the track, here it is at 00:05:46(75).

The Trim points can be set by using the nudge buttons in the Trim In and Out sections or by using the mouse buttons in the waveform display area - left click sets in point, right click sets out point and centre click or shift+left click cues the track to that point.

In the Trim In and Trim Out displays, left clicking the trim value will mark the current value as that trim point. The two clear buttons return the In and Out points to the start and end of the track respectively. Keyboard qwerty keys 'i' and 'o' can be used to mark the In and Out points respectively.

Right-clicking on the trim In timecode display brings up a menu where the value can be entered numerically and also pasted to a local clipboard. The clipboard contents can be swapped between In and Out points so allowing a Play to In point function.

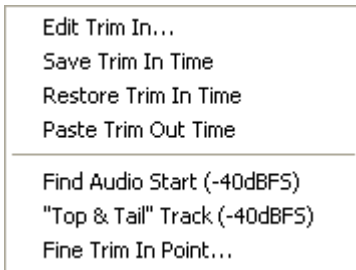

Selecting Edit Trim In displays a timecode editing dialog using the mm:ss:ff(75).

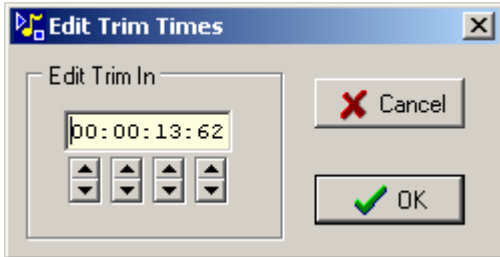

Using the Fine Trim In Point option the In Point can be precisely positioned with sample accuracy, below is an example using the 1kHz GLITS test signal.

Initially the In Point - shown by the vertical magenta line - will be set at the start of the waveform displayed with a 5 second horizontal axis.

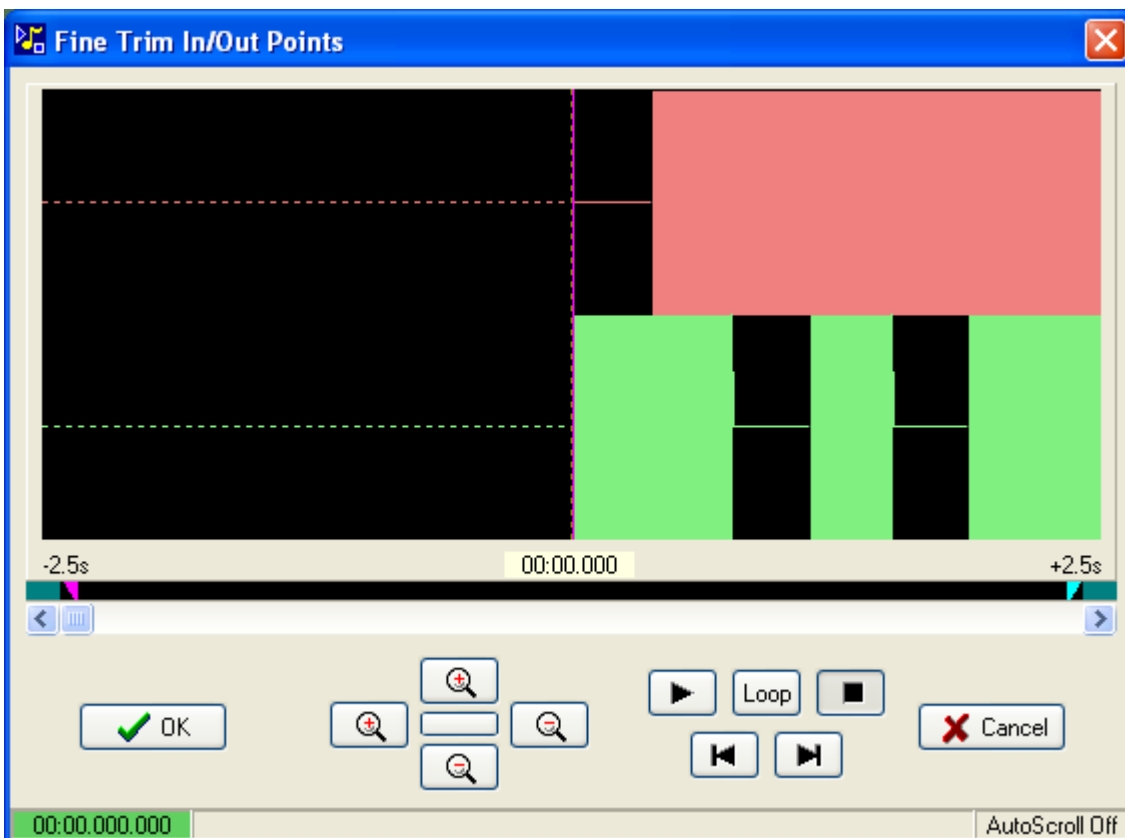

If the In Point was required to be at the beginning of the second burst on the right channel the waveform can be scrolled and zoomed to show 5mS of the waveform and the In Point positioned precisely.

Left clicking the mouse will move the In Point to the new position, similarly right-clicking will move the Out Point.

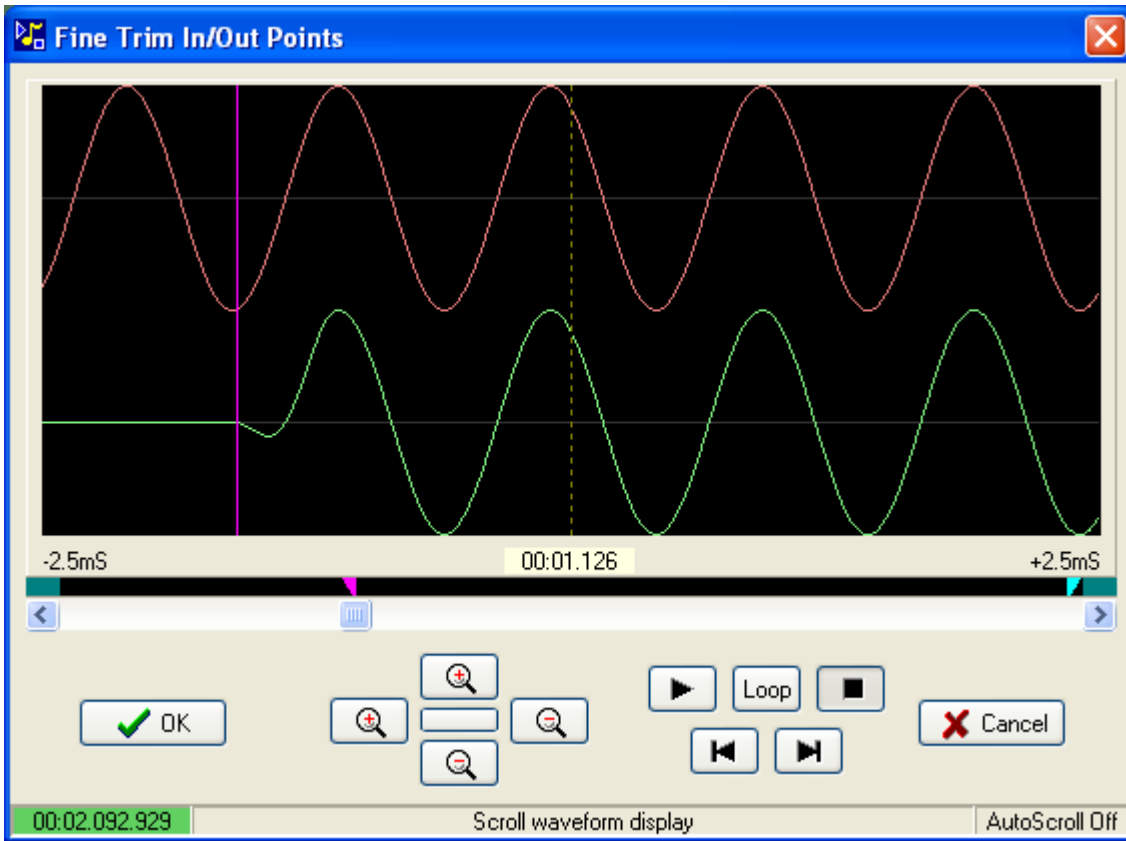

The waveform can be re-centred by clicking the Cue to In button.

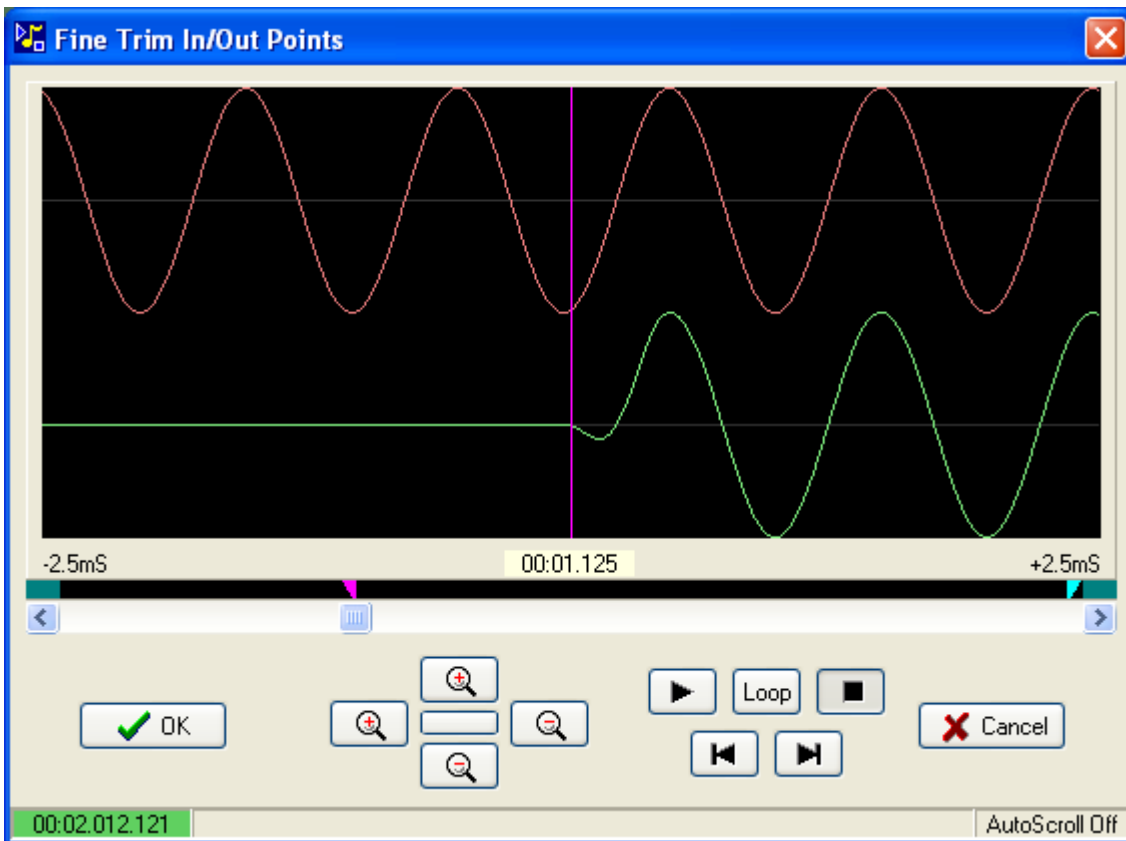

The position display 00:01.125 shown under the centre line is of the form minutes:seconds.milliseconds, alternative displays are available by right clicking the time display label

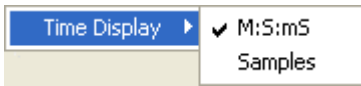

The samples option shows the sample number

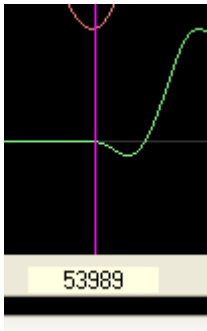

All time displays are reference to the start of the audio waveform irrespective of any Trim In Points that have been set.

At horizontal display widths of 10mS or less the Show Levels option is enabled and will display the levels for the tracks in absolute sample value.

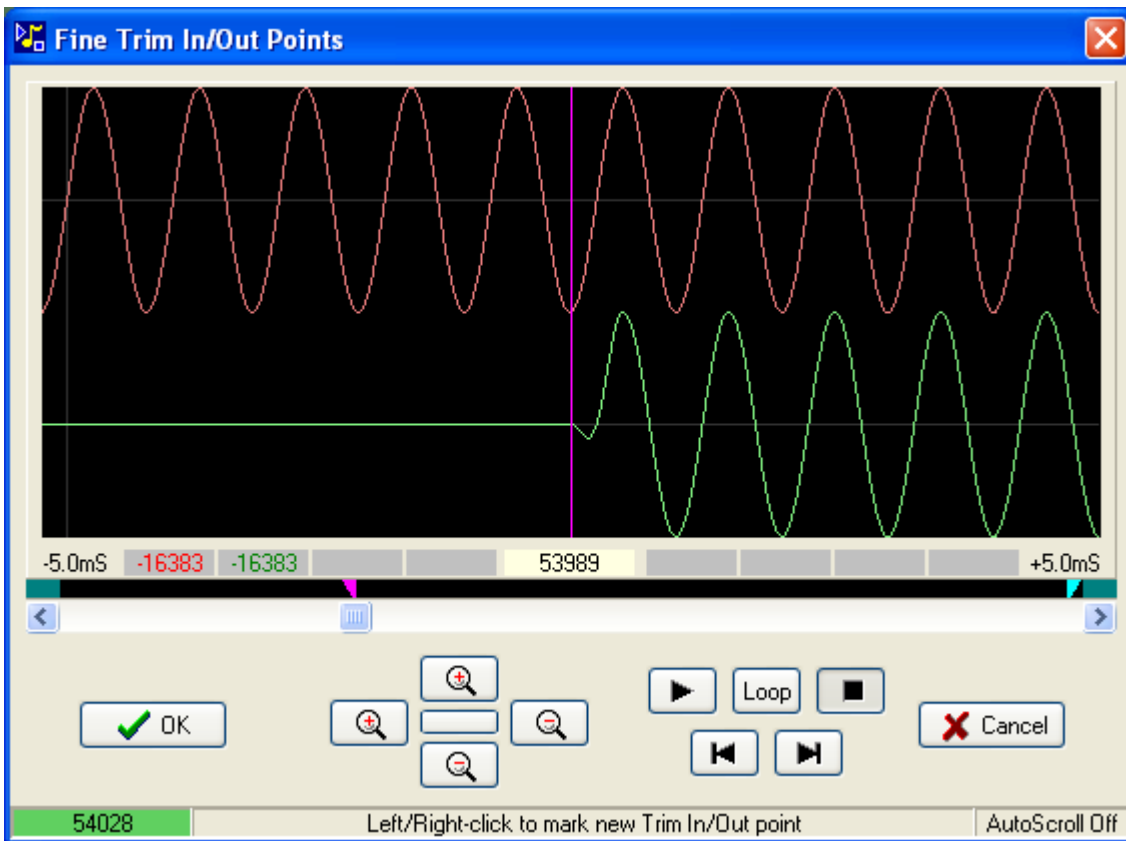

If the time display mode is set to M:S.mS then the levels are shown in dBFS

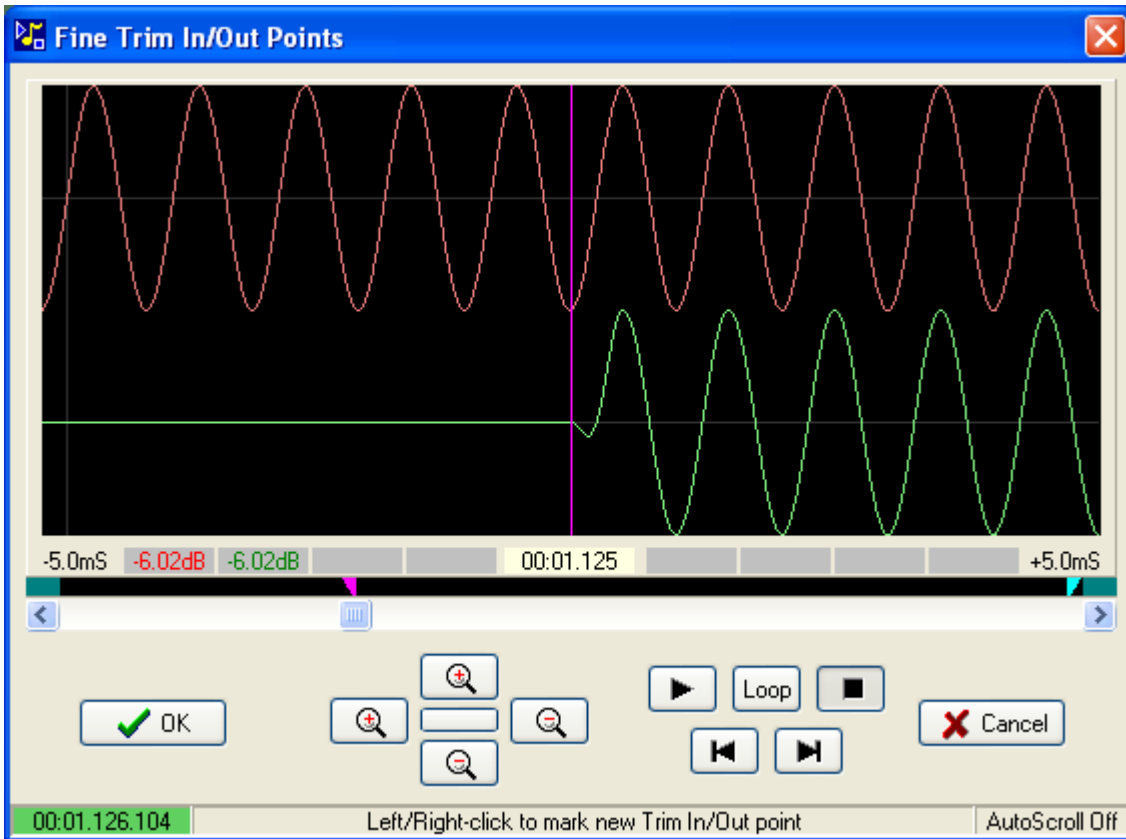

Multichannel (5.1) tracks are displayed as shown below.

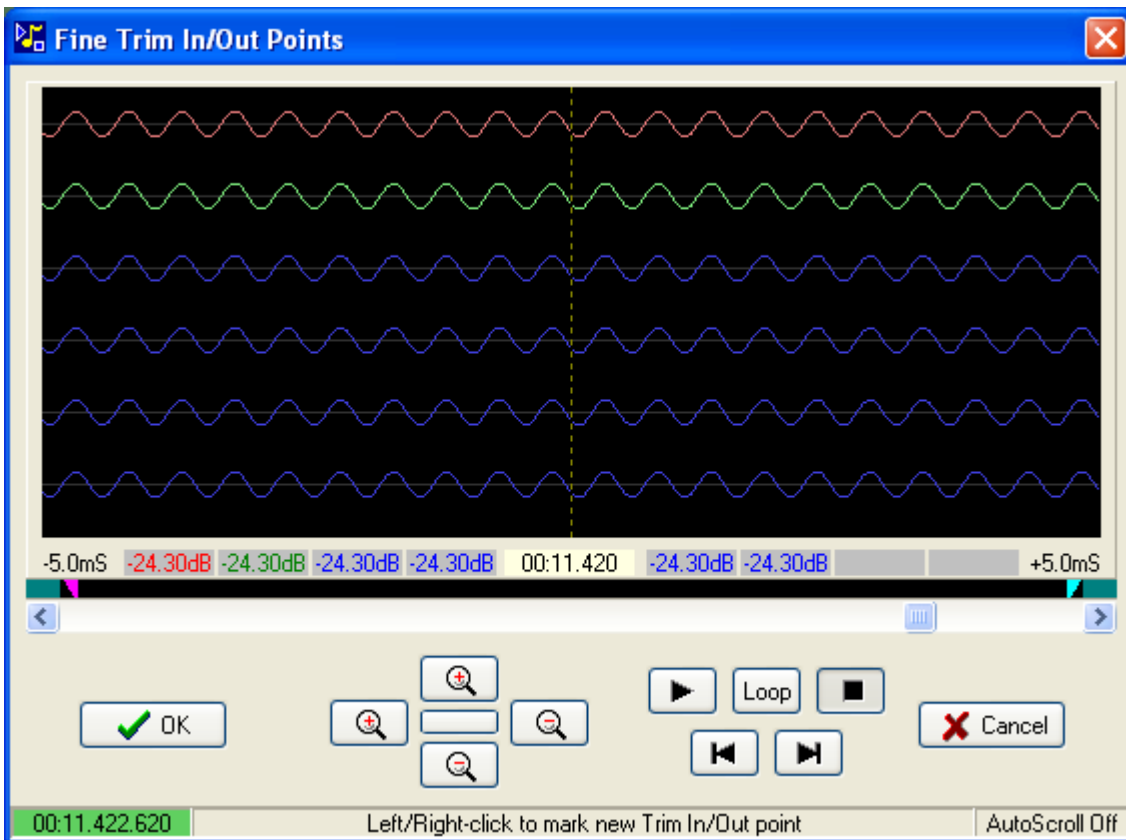

Both Trim In and Trim Out points can be set in this dialog, the In and Out points are shown in magenta and cyan respectively.

The Trim In and Trim Out tabs move the In or Out point to the centre of the screen

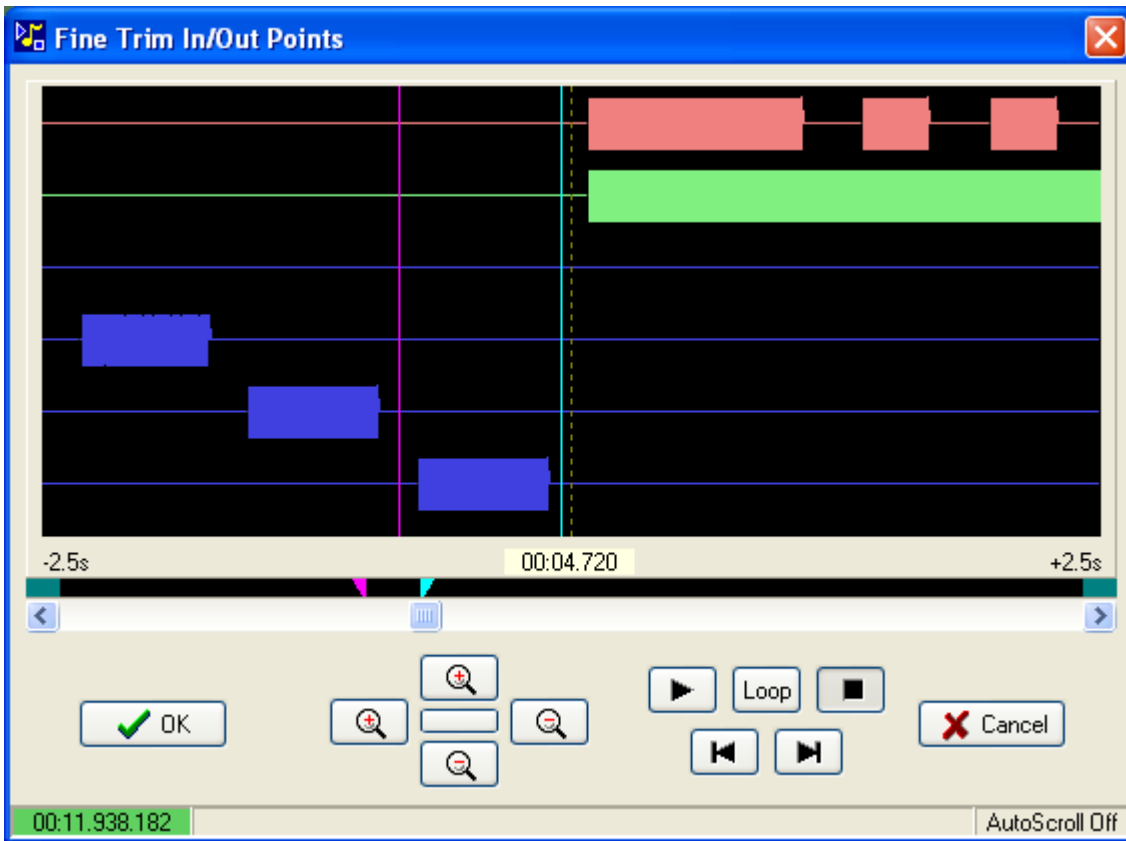

In addition to left/right clicking on the waveform to position the In/Out points, the coloured triangles in the Marker Bar section below the waveform can be dragged to the approximate position.

If the In and Out points are too close to be separated they will be shown together as a blue triangle



The individual points can still be dragged, but this time by using Left drag for the In point and Right drag for the Out point.

The In and Out points can be cleared by clicking on the coloured sections at the left and right ends of the marker bar.

When the track is playing, a yellow vertical line is shown on the Marker Bar indicating the current position within the track.

Keyboard qwerty keys 'i' and 'o' can be used to mark the In and Out points respectively.

By default the waveform display is static, however it can be scrolled as the track is played by clicking on the AutoScroll On/Off panel on the lower right of the dialog box.

When AutoScroll is On and the track is playing the display can be frozen by pressing 'f' on the keyboard.

The display buttons shown below control the horizontal timebase (left and right buttons) and vertical gain (top and bottom buttons) of the the waveform, the unlabelled centre button clears the timebase and gain to the default values.

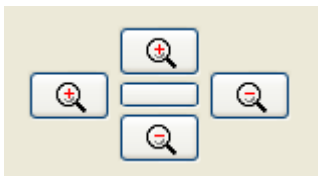

## Level Meters

On the right hand side of the graph are peak reading level meters with the same range as the graph scale and attack and decay times similar to that of a PPM, the readings include modifications made by the Pan, Gain and Mute controls.

In the Stereo version of SpotOn there are two meters which can display either L/R or M/S signals the selection is made by right-clicking on the bargraphs, the selection is reset to A/B when the window is closed. The mode is shown by the text immediately above the bargraphs, this text will be red if the track is muted.

- A/B
- M/S (M6)
- PPM
- LED Style
- Soft Cursor

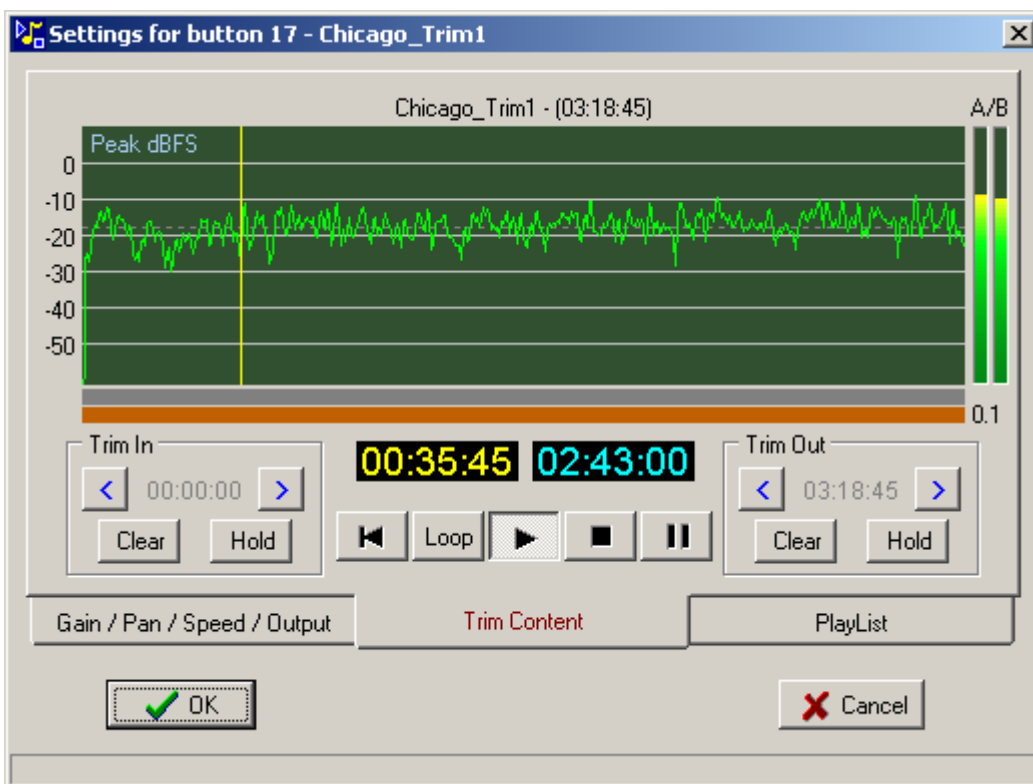

In the MultiChannel version of SpotOn there are six meters Left, Right, Center, LFE, Rear Left and Rear Right

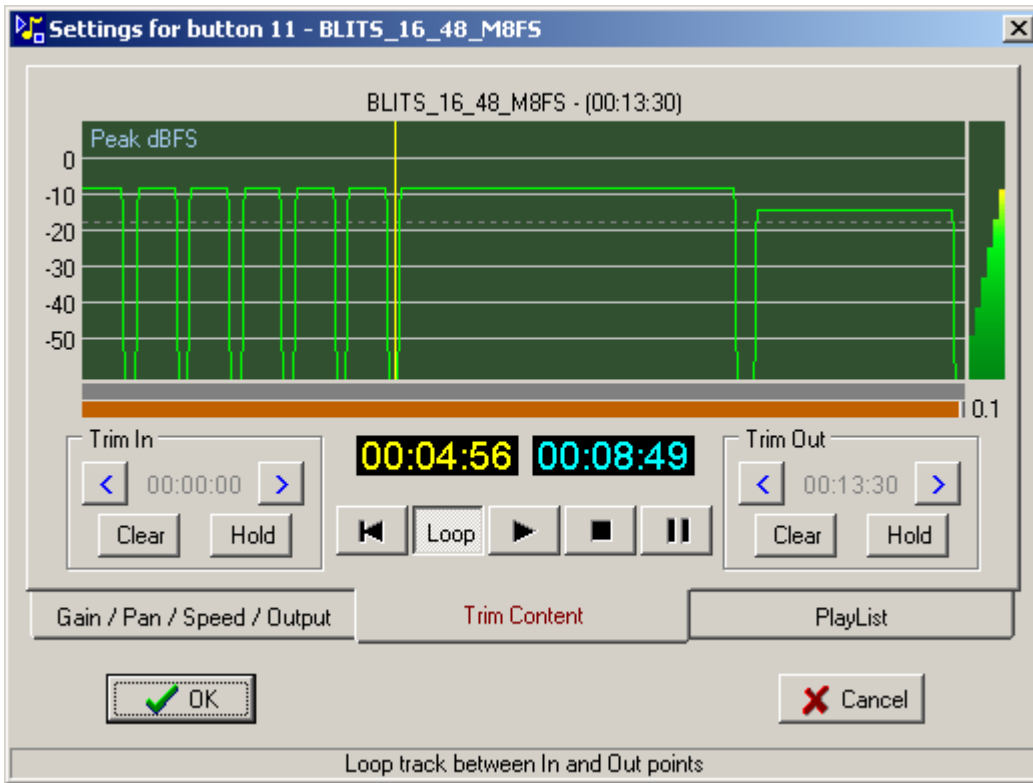

Option 3 changes the level meters to a PPM style of response with PPM6 representing 0dBFS

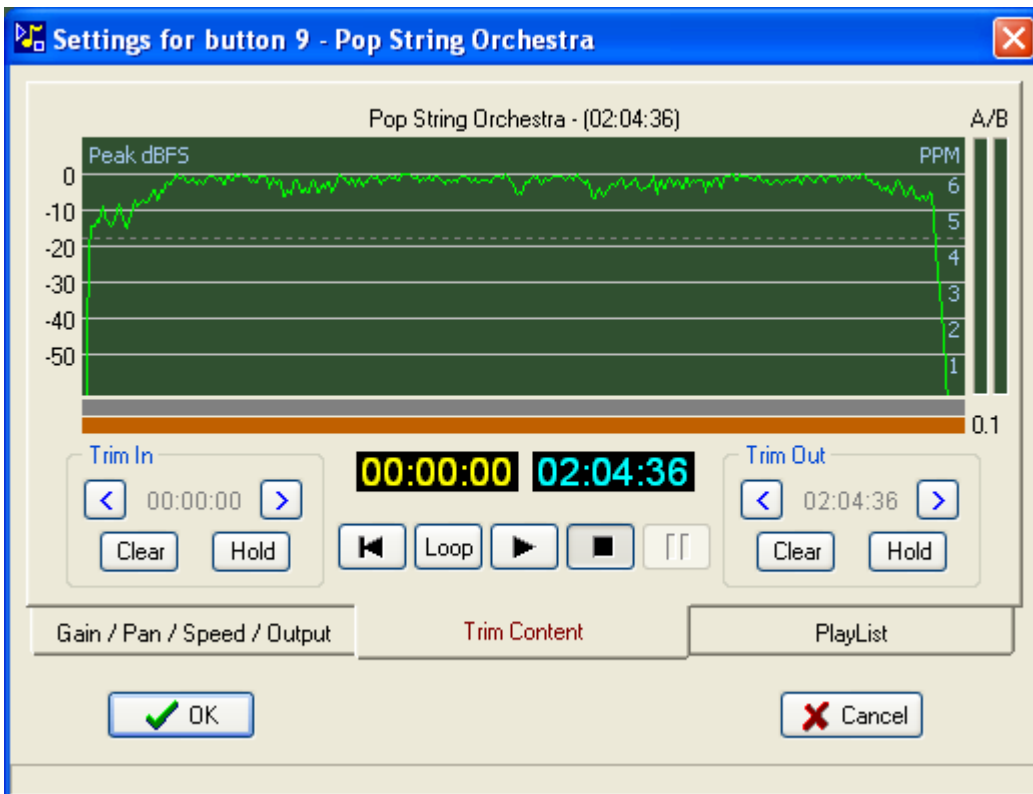

The fourth option in the popup menu is 'LED Style' which shows the bargraphs as a series of individual LEDs instead of a continuous bar, this option is saved with the session file.

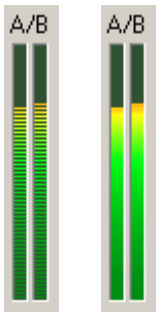

The final option in the Level Meters popup menu is Soft Cursor, when selected the yellow positional cursor on the waveform will track in quarter pixel steps allowing smoother and more accurate movement.

## AutoTrim

The Find Audio Start item in the Trim In popup menu scans the audio waveform and marks the In point where the audio level exceeds a certain threshold, here it is -20dbFS. In the example shown below there is a long gap at the start of the audio before any modulation appears, this could be trimmed by trial and error or automatically by using the AutoTrim feature.

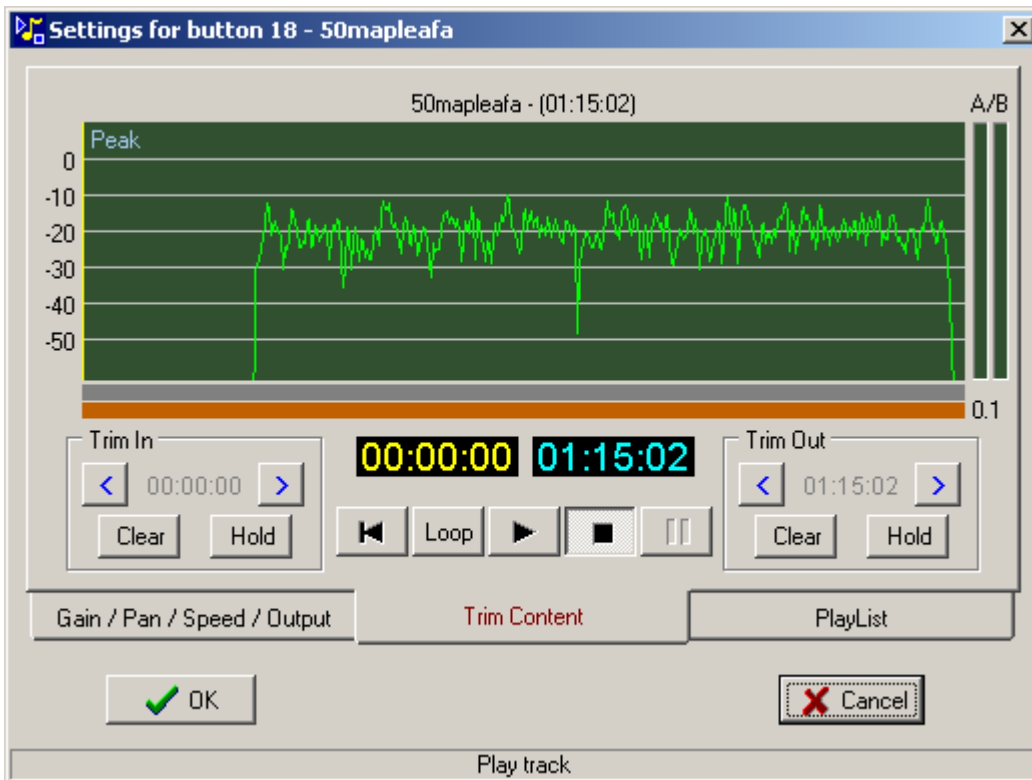

Below AutoTrim has positioned the Trim In point at the start of the audio modulation

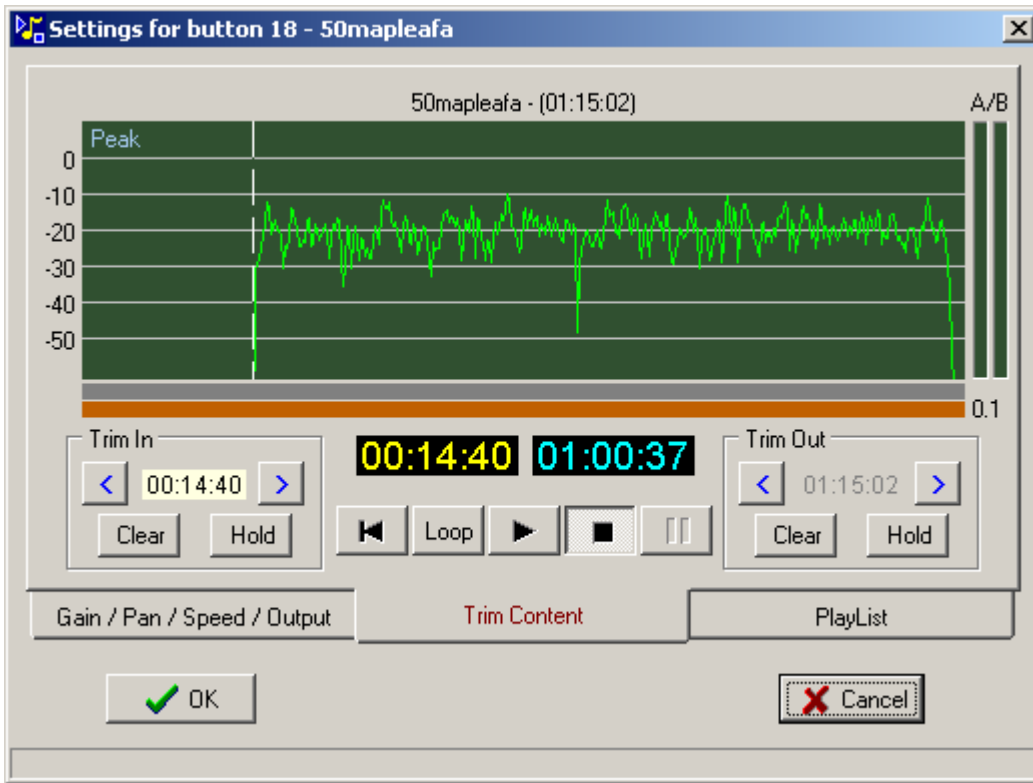

Similarly The Trim Out menu has a Find Audio End option which locates the last audio modulation

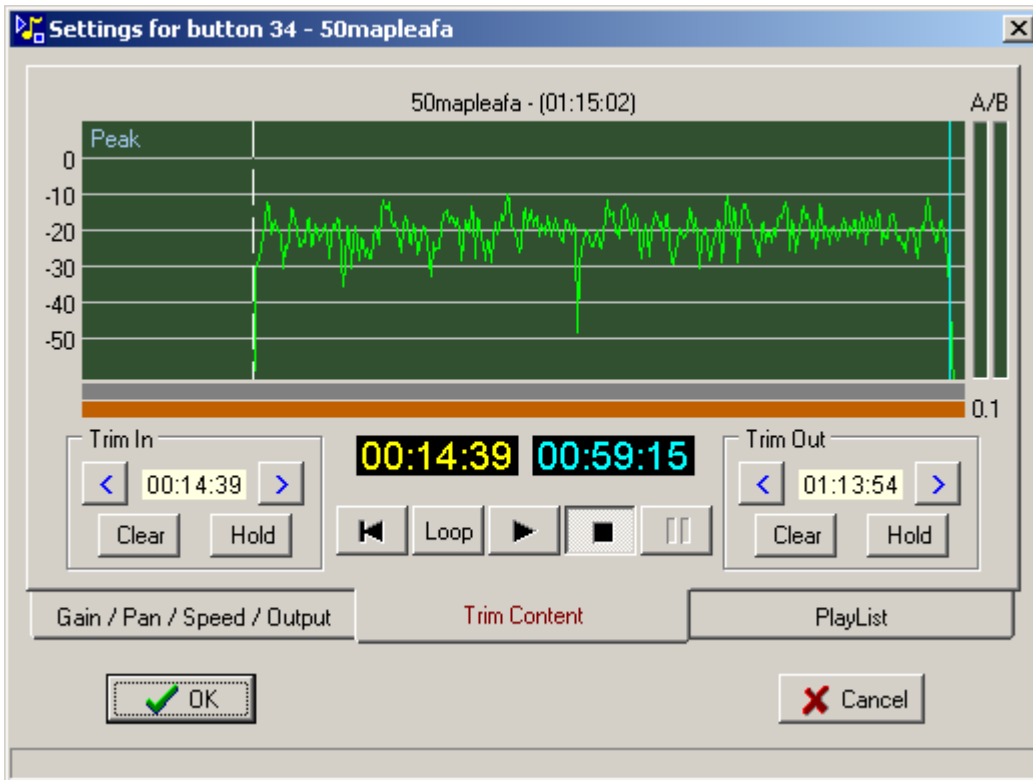

The Find Audio Start/End functions are combined in the "Top & Tail" Track option in the Trim In menu where AutoTrim trims both start and end of the track

## Play to In Point

Play To In Point can be achieved by right-clicking the left hand (elapsed time) display which will show a list of rehearsal times, some may be greyed out if the InPoint is close to the start of the track.



Continuing with the example shown above the action of selecting a 2.0s In Point rehearsal will temporarily adjust the In and Out markers to surround the material to be rehearsed

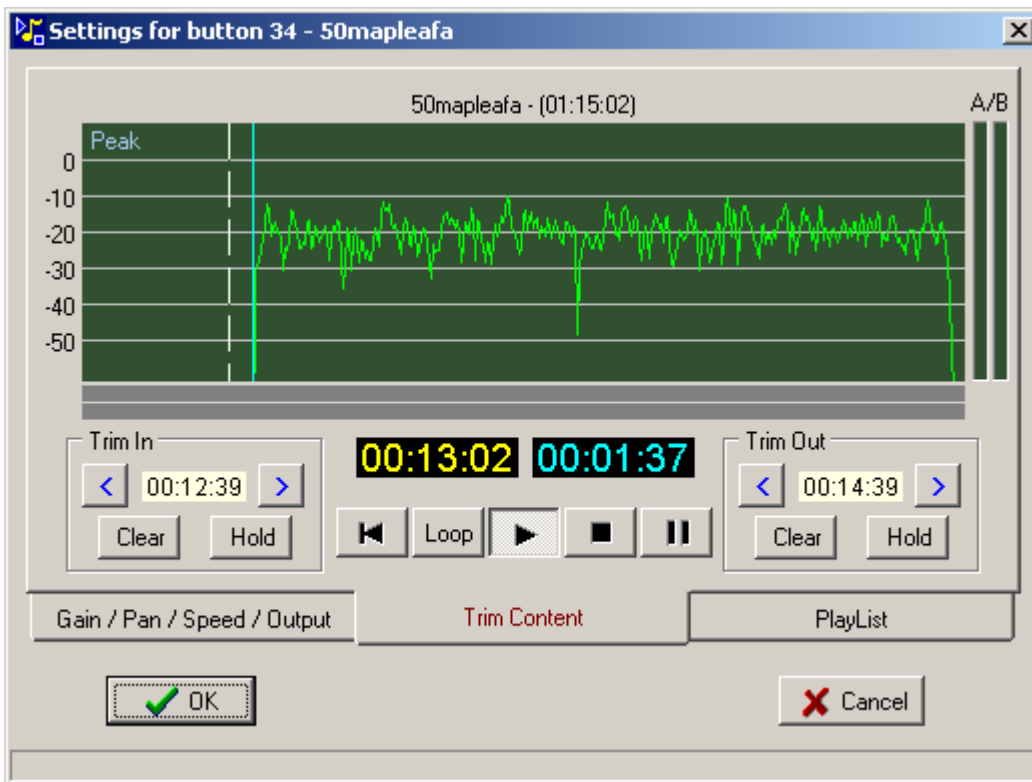

The material up to the In Point can be reviewed and the In point adjusted by clicking on < and > in the Trim In section.

If Loop is selected instead of play then the section will be played repeatedly and the In Point adjustment will be heard directly, remember to deselect Loop otherwise it may be inherited by the button when the dialog is closed.

The Out point will return to the original value when the track is stopped or the dialog box closed.

The button display indicates whether Trim In '>' and Trim Out '<' are active, both ends of the track being trimmed is shown by an 'X' prefix.

SOUND181	SOUND240	SOUND104
62a >00:02	63a <00:01	64a X00:01

Just below the waveform are two horizontal lines coloured brown with black/white transitions (Fade Bars), these represent a graphical display of the fade in and fade out timings where black is -40dB and white is 0dB gain. The fade times can be modified by dragging along the fade bars.

The -40dB level is the default for fades and can be set via [Options|Gain Settings|Fade In/Out Depth](#)

The two time code values show - in yellow the elapsed play time and in cyan the time remaining.

## Rehearsal

Rehearsal of the last xx seconds of a clip can be achieved by right-clicking on the right hand (time remaining) display, this will show the following popup menu



Clicking on any item will cue the track to xx seconds before the Out Point and play until the end.

Entries in the popup menu will be disabled if the rehearsal time is greater than the track length.



## Transport



The transport buttons control playout of the track, working from the left the button functions are:-

- Cue - to start of track or In point if defined
- Loop - between start/in point and end/out point of track
- Play - spacebar will play track from In Point
- Stop - spacebar will stop and recue track to In Point
- Pause - toggles Pause/Play  
Note: Pause cannot be used if the track contains a Playlist

## Timecode Chase

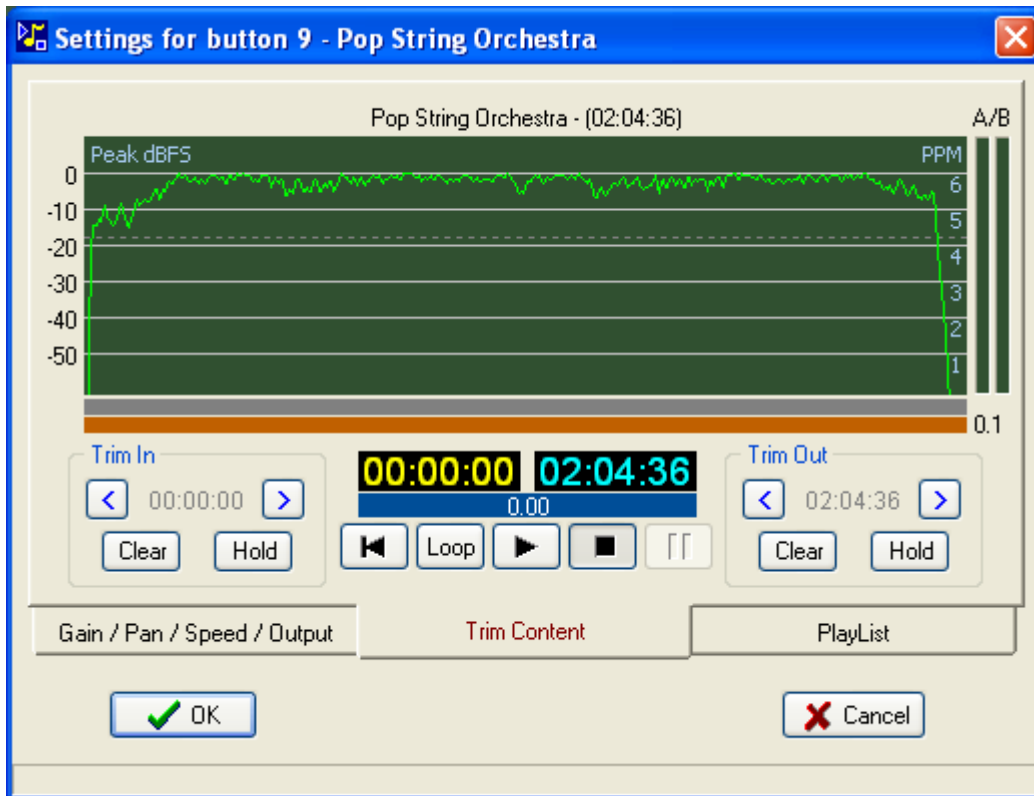

If [Timecode Chase](#) is active the current time offset error averaged over one second is shown in the blue panel above the transport controls.

Clicking on this panel will force a resynchronisation of the track to the external timecode

## Virtual Playlist Segments

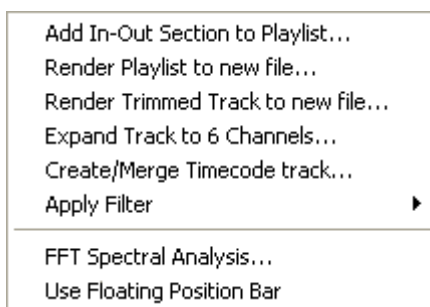

The menu item [Add In-Out Section to Playlist](#) will add three new (virtual) playlist segments comprising Start>In, In>Out and Out>End.

These playlist segments can be used just as any other, their intended use is to enable a quick method of removing a section of audio defined by the Trim In and Trim Out points

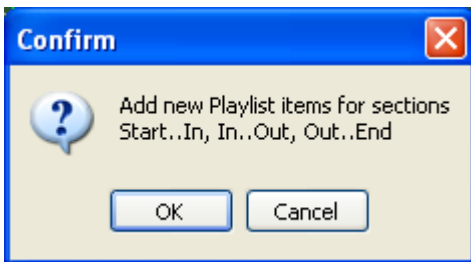
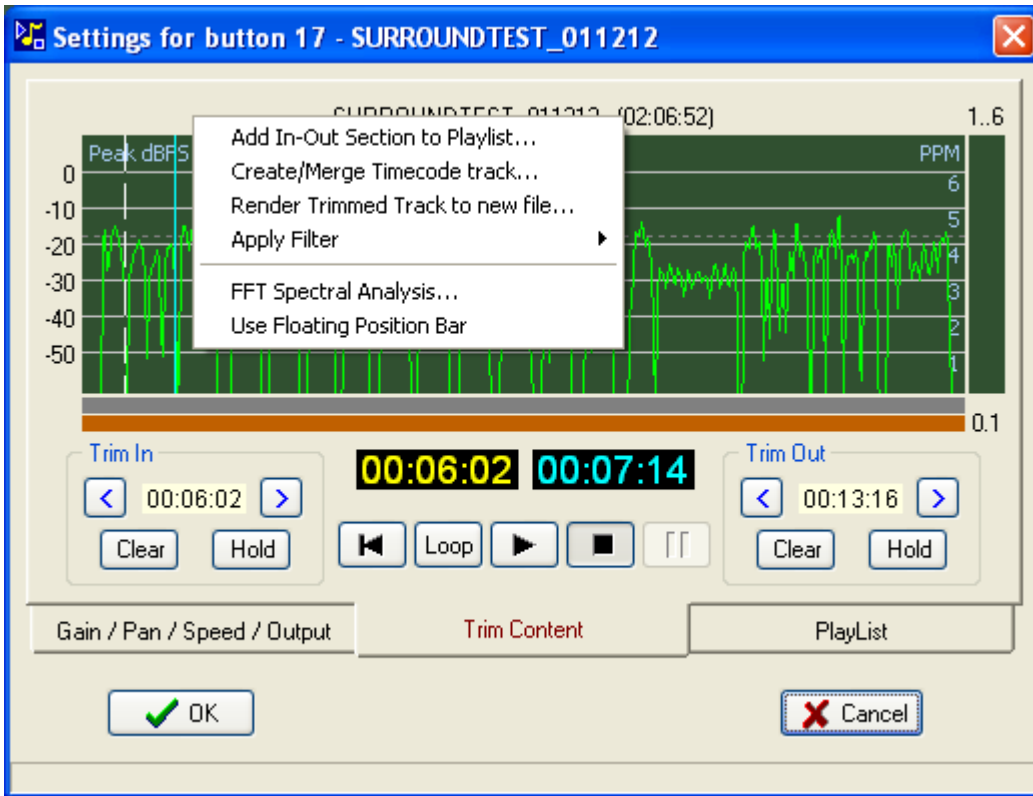

Moving to the PlayList tab will show the three new items

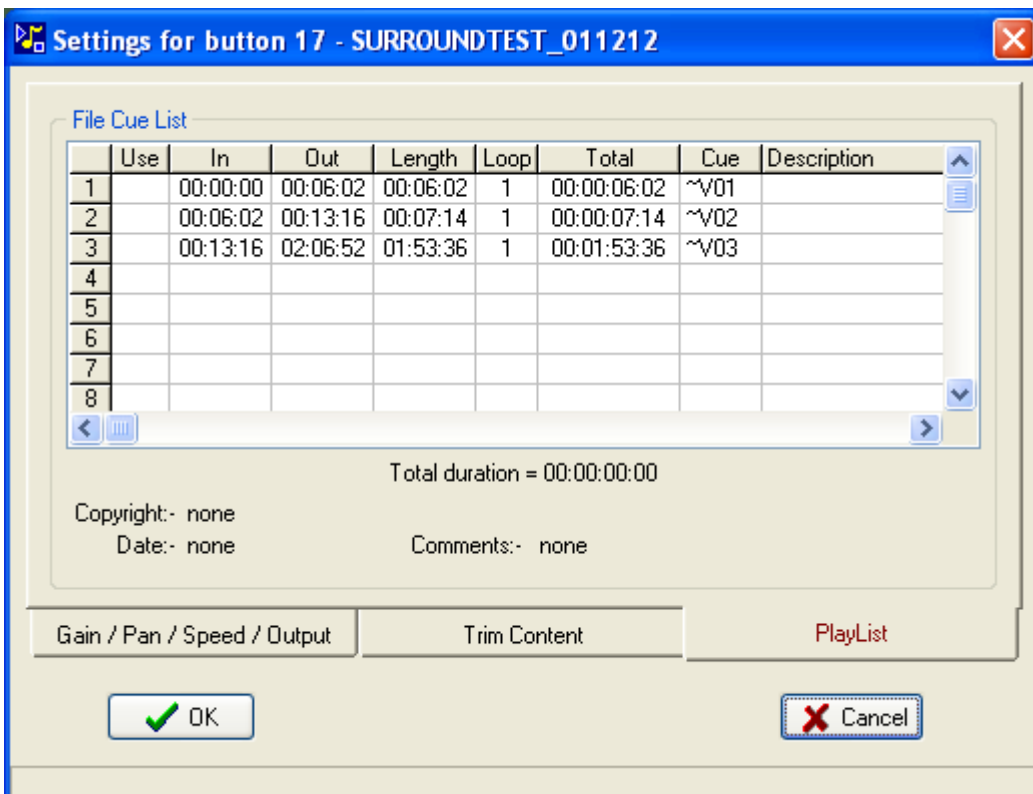

Checking segments 1 and 3 will cause the track to skip the Trim In..Trim Out section

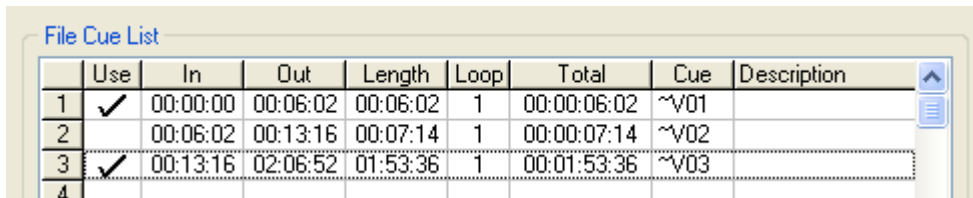

	Use	In	Out	Length	Loop	Total	Cue	Description
1	✓	00:00:00	00:06:02	00:06:02	1	00:00:06:02	~V01	
2		00:06:02	00:13:16	00:07:14	1	00:00:07:14	~V02	
3	✓	00:13:16	02:06:52	01:53:36	1	00:01:53:36	~V03	
4								

Right-clicking on the In column entries will display further options

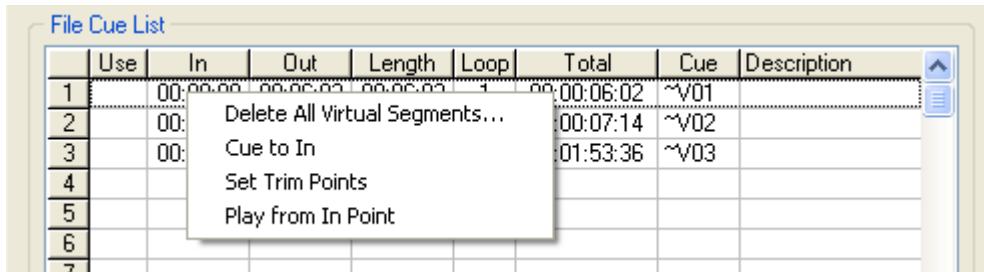

	Use	In	Out	Length	Loop	Total	Cue	Description
1		00:00:00	00:06:02	00:06:02	1	00:00:06:02	~V01	
2		00:06:02	00:13:16	00:07:14	1	00:00:07:14	~V02	
3		00:13:16	02:06:52	01:53:36	1	00:01:53:36	~V03	
4								
5								
6								
7								

- Delete All Virtual Segments...
- Cue to In
- Set Trim Points
- Play from In Point

Some options are disabled when the Playlist is active

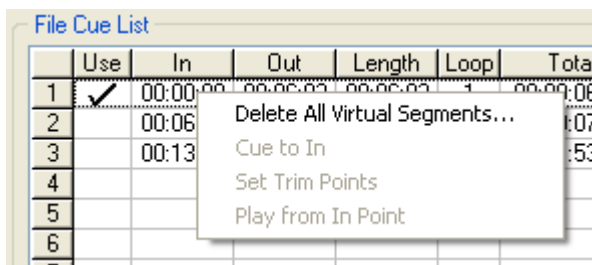

	Use	In	Out	Length	Loop	Total	Cue	Description
1	✓	00:00:00	00:06:02	00:06:02	1	00:00:06:02	~V01	
2		00:06:02	00:13:16	00:07:14	1	00:00:07:14	~V02	
3		00:13:16	02:06:52	01:53:36	1	00:01:53:36	~V03	
4								
5								
6								
7								

- Delete All Virtual Segments...
- Cue to In
- Set Trim Points
- Play from In Point

Delete All Virtual Segments will remove all playlist items added since the file was loaded, that is all items with names starting "~V"

Cue to In will cue the track to the In Point of the selected playlist segment

Set Trim Points will reset the track Trim In and Trim Out points to match the selected Playlist segment so that the timing can be adjusted if necessary

Play from In Point will play the track from the In point of the selected Playlist segment.

## Render To New File

The right-click options in the Trim window include the option to Render Playlist to new file.

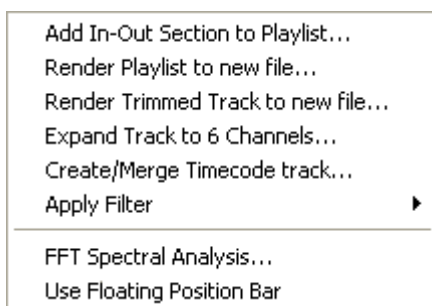

- Add In-Out Section to Playlist...
- Render Playlist to new file...
- Render Trimmed Track to new file...
- Expand Track to 6 Channels...
- Create/Merge Timecode track...
- Apply Filter
- FFT Spectral Analysis...
- Use Floating Position Bar

Choosing that option will display a setup dialog enabling selection of the track parameters to be rendered, the Mix Down options are inoperative in this mode.

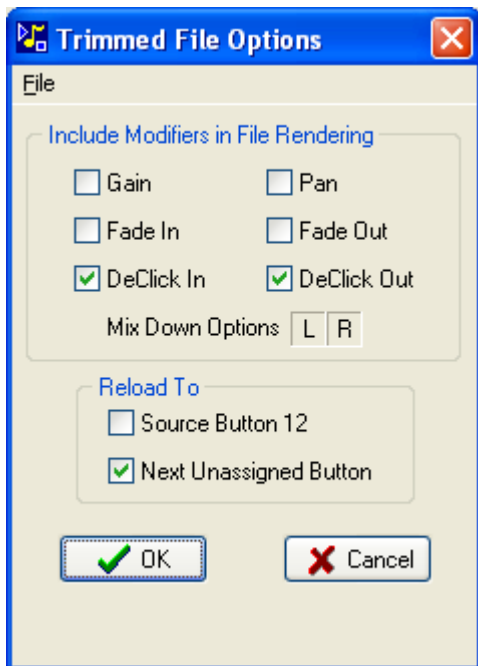

## Expand Track Channels

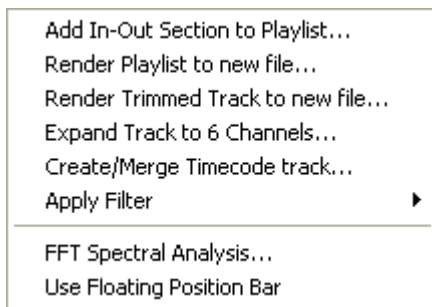

If the button track consists of either 1 or 2 channels and SpotOn is in MultiChannel mode, the Expand Track to 6 Channels option will create a new WAV file with the original audio data and at the same time increase the number of tracks to 6.

The reason for this option is to allow the 5.1 surround sound panning of mono and stereo tracks.

Mono and stereo tracks cannot be panned directly in 5.1 mode, however they can be converted to 5.1 tracks with this option and then panned +/- 180 degrees.

The default name of the expanded track is OriginalName\_!6ch!.wav, the name and location can be changed in the dialog box below

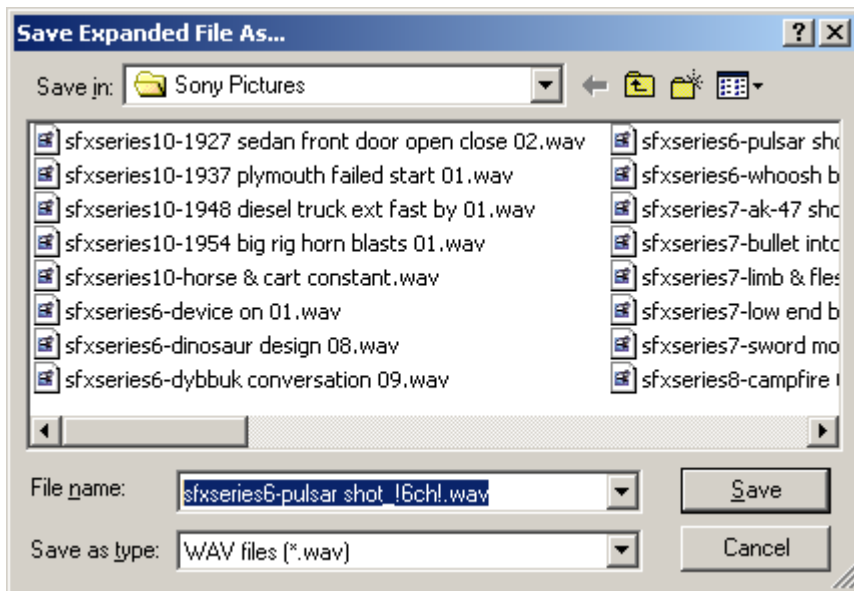

If the file already exists then a warning prompt box will appear

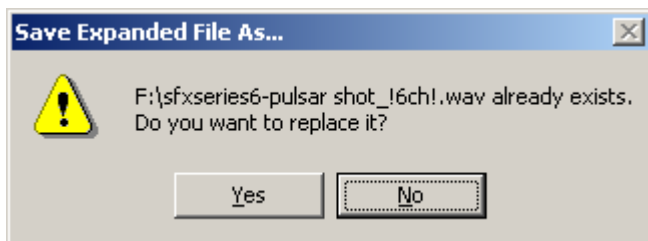

The progress of the expand process is reported along with the option to cancel.

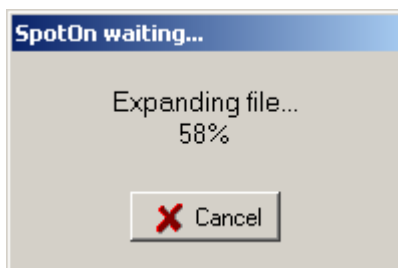

Finally the option to load the expanded track onto the next available button is offered, the button will be loaded when the main Audio dialog window is closed.

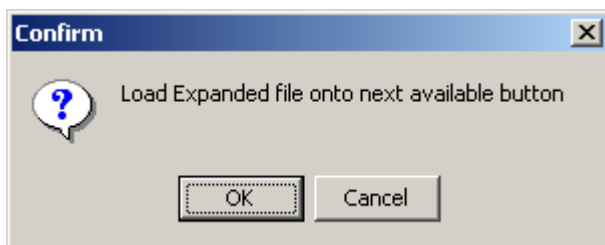

## Create Timecode Tracks

An associated timecode track can be generated from a button track, most tracks do not have any form of timecode reference so a default timecode range starting at 00:00:00:00 will be shown.

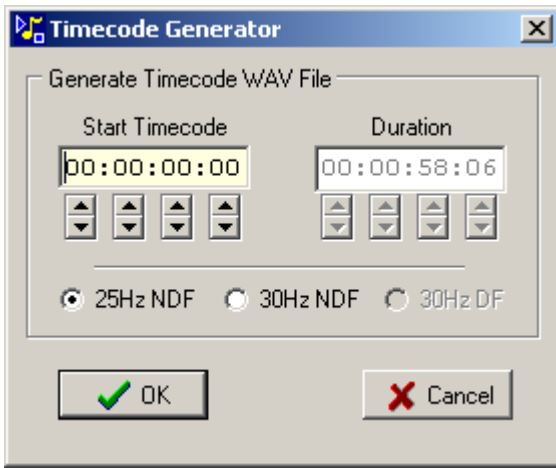

In the case of a BWA (Broadcast WAV) file there is a start timecode embedded within the metadata and this is used as the start value for the timecode file.

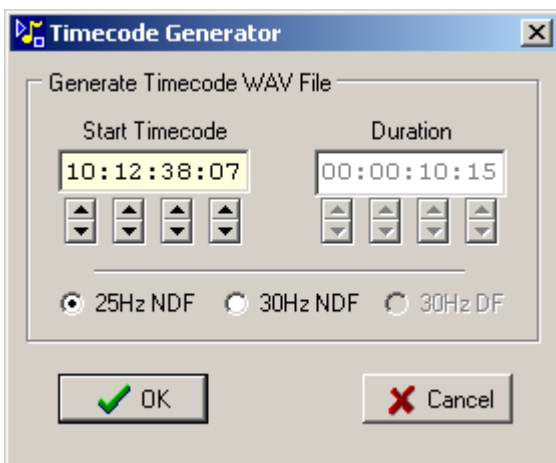
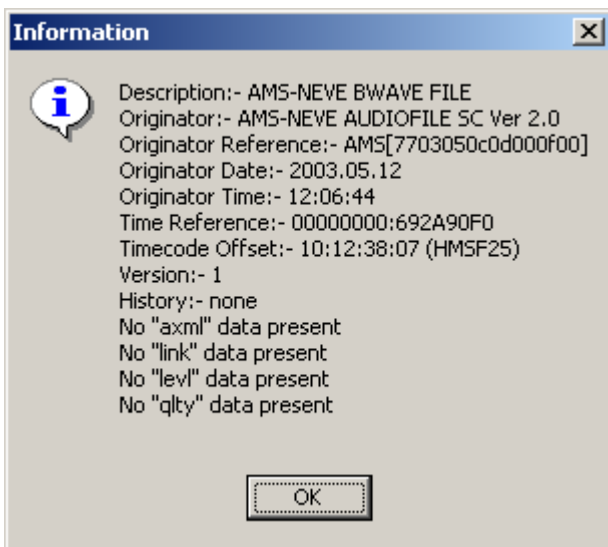
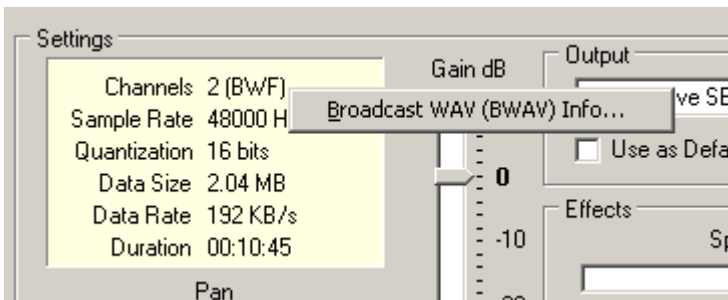

In both cases the duration is fixed by the length of the track.

On clicking OK the default filename for the separate timecode track will be displayed, the name format is:-

TrackFilename\_!Timecode!.wav

making it distinct from ordinary tracks

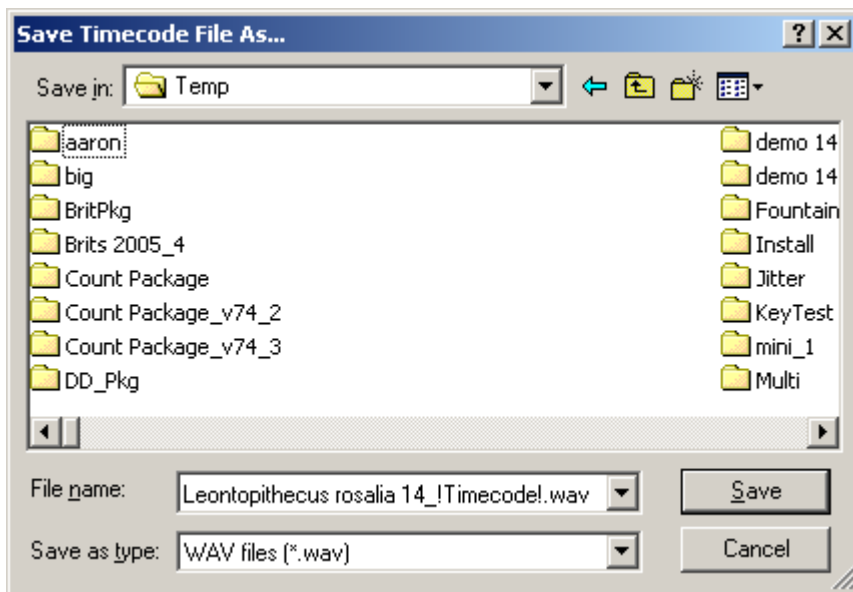

If the file name already exists and overwrite prompt box is shown.

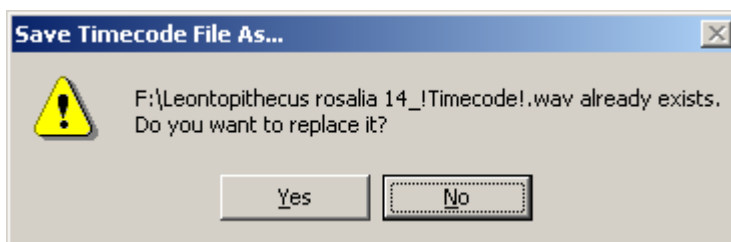

The creation of the timecode file can take some time so a progress box is shown, the cancel button will abort the operation

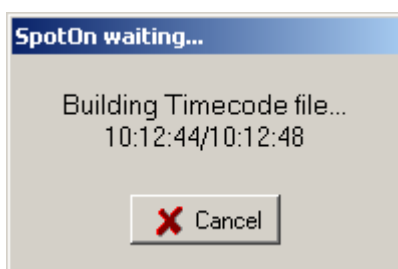

After saving the timecode file, the next stage offers the option to merge the timecode file with the original audio track, this option is only available on the multichannel version of SpotOn.

The original stereo audio will be transferred to tracks 1/2 of a 6 channel WAV file and the timecode can be placed on any of the remaining 4 tracks

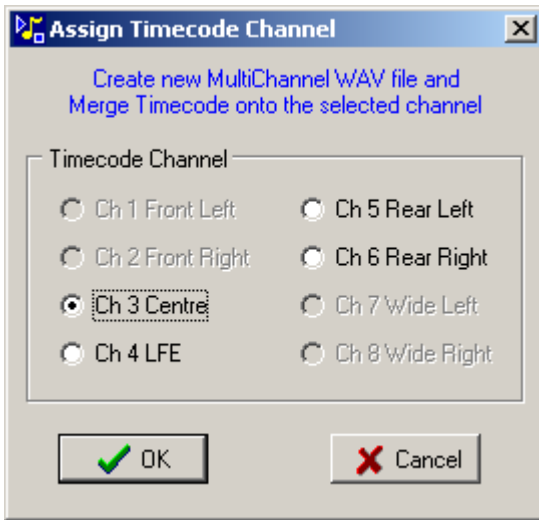

In the case of a 8 channel (7.1) version of SpotOn a 5.1 track can have timecode merged into either tracks 7 or 8



The default name for the merged file is:-

TrackFilename\_!Merged!.wav

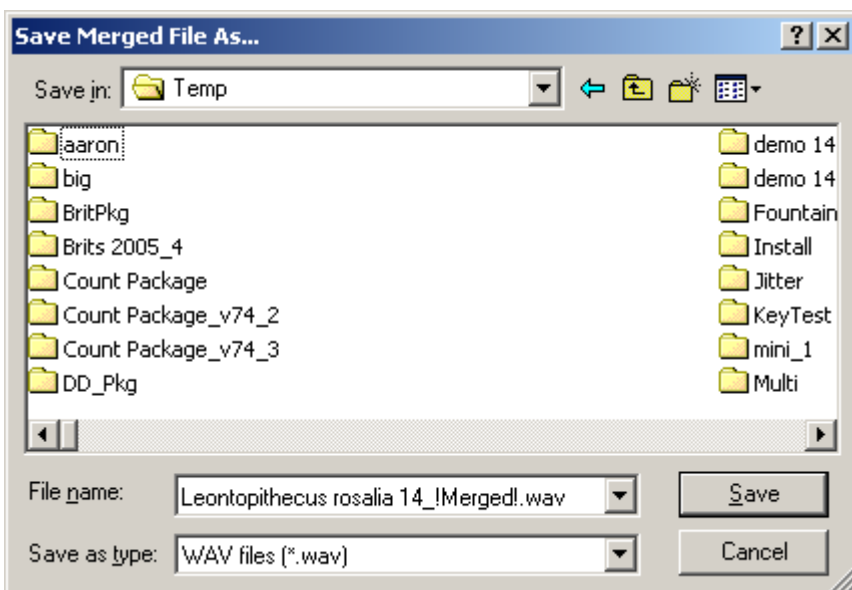

In the case of the file already existing the overwrite prompt dialog will appear

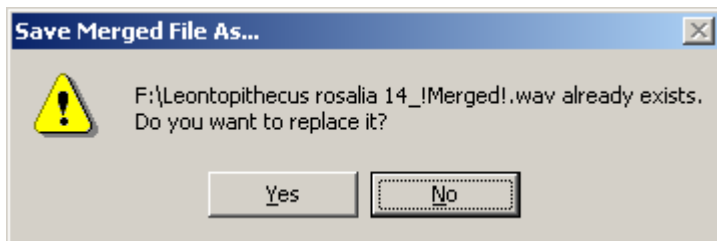

Finally the option to load the one or two files generated onto the next free button/s is shown

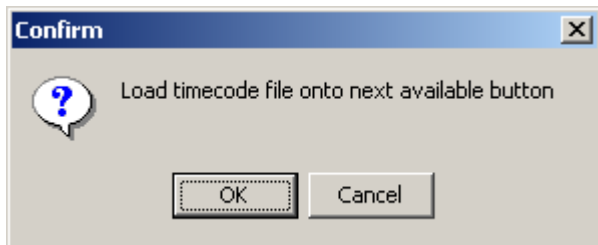

## Render Trim

The trimmed audio track can be saved as a new file by right-clicking the Track name label at the top of the waveform window

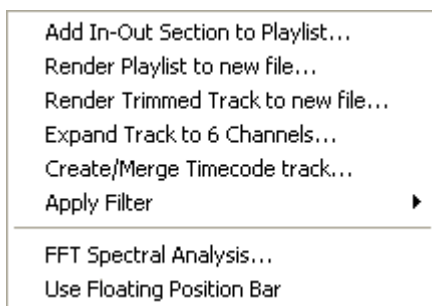

Selecting 'Render Trimmed Track to new file' displays the dialog box below with options to include the Gain, Pan, Fade In and Fade Out modifiers in the new file which will be rendered from the original.

The DeClick In and DeClick Out options are checked by default these add 10mS fades at the start and end of the trimmed file to avoid sharp waveform transitions, these options can be unchecked if the start and end transients are to be preserved.

The Mix Down options are initially set to be that of the button settings but can be temporarily changed to the render the file.

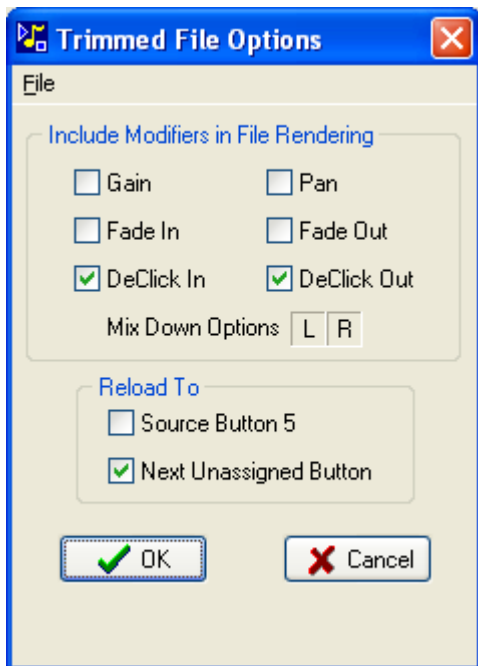

The button being edited can be reloaded with the new rendered file by checking Reload To Source Button, alternatively the file can be loaded onto the next unassigned button.

The default name for the rendered file is "OriginalFilename\_Trim1.wav" and it will be saved in the same folder as the original file.

The filename and location of the rendered file can be changed from the default by opening up the File menu



Here a standard Windows file selector dialog is displayed

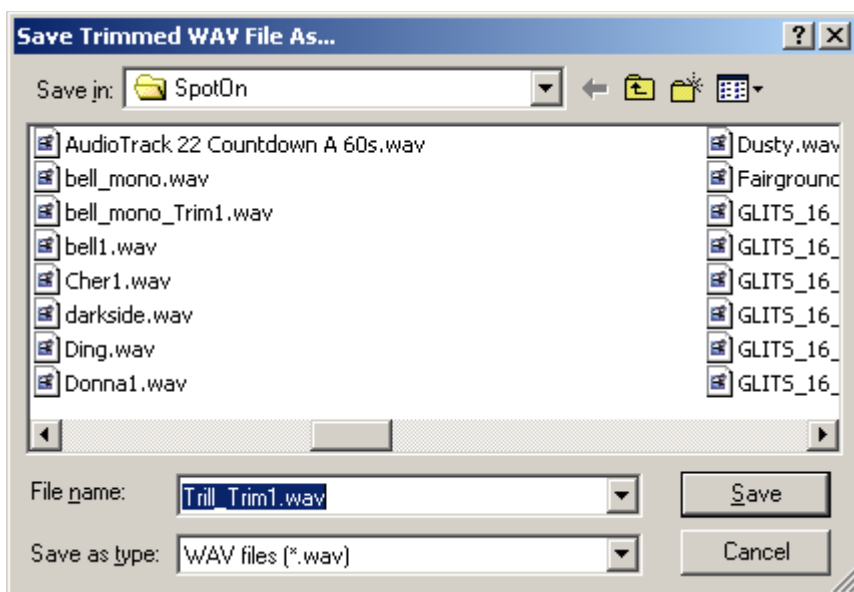

Enter a new filename and click Save to change the rendered filename or location.

The button will not be reloaded until the Audio Settings dialog is closed by clicking OK

## RePatch MultiChannel Files

Some applications export multichannel (interleaved) WAV files with a non-standard track order, this dialog allows the ProTools channel ordering to be changed to the audio standard.

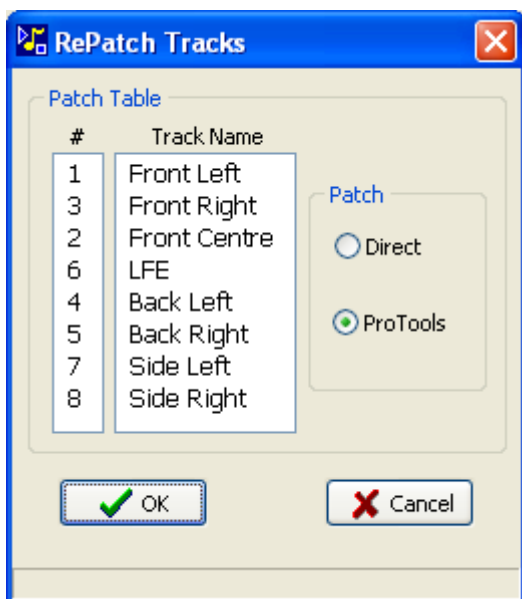

## Filter Track Audio

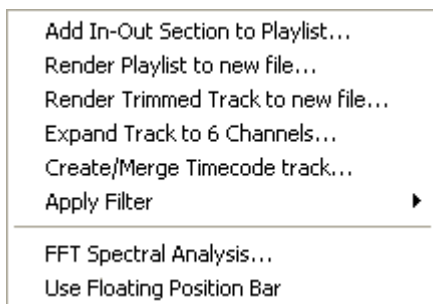

Using the Apply Filter item one filter can be selected from the range

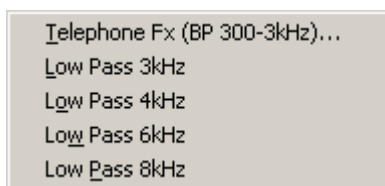

The filtered version of the track can then be saved as a new file, the default name is the original file name with "\_!FxFilterX!" added as a suffix.

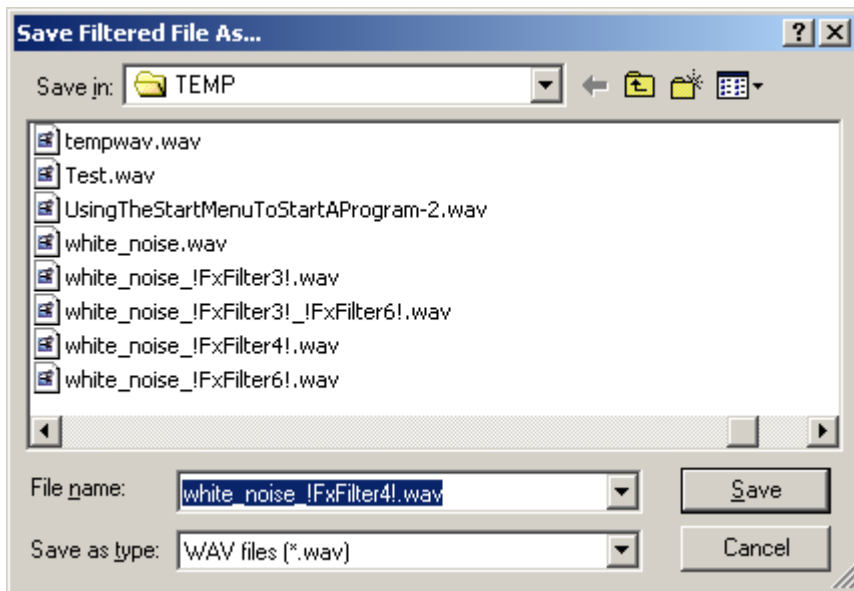

Applying the filters involves a large amount of mathematical calculations and in some cases the filter will take some considerable time to complete - approximately 3x real time. The filters are linear phase and have a 3dB passband ripple and 40dB stopband attenuation.

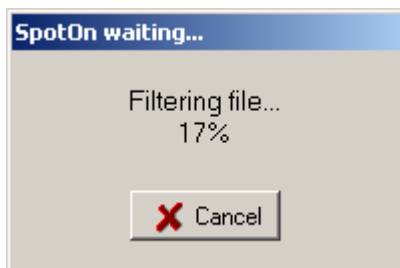

### Spectrum (FFT) Analysis

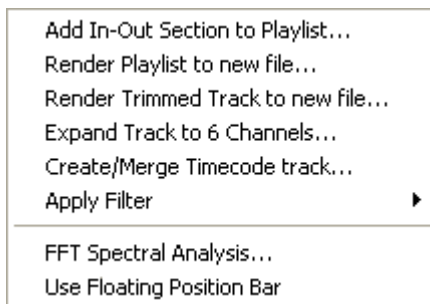

Selecting 'FFT analysis' from the title right-click menu opens up a new window displaying a blank spectrum plot

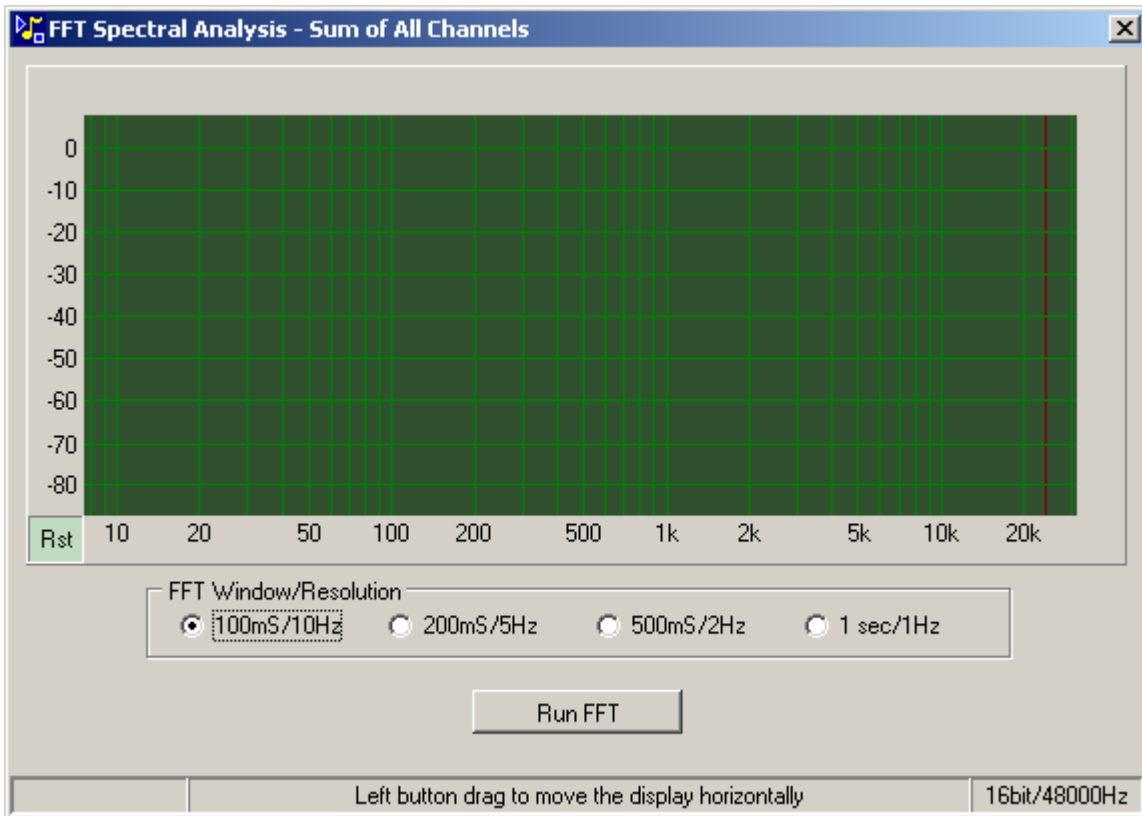

The FFT Window/Resolution options select the resolution of the display between 1Hz and 10Hz, the 1Hz setting will give the most accurate plot, click the Run FFT button to analyse the file.

The analysis takes some time to complete - approximately 5x normal speed eg a 20s stereo track is analysed in 4s.

The analysis of the 6 channel BLITS waveform is shown below, here the main frequencies of 82.5, 660, 880, 1000 1320 and 2000Hz can clearly be seen, the other spectrum lines are a result of the modulation of the main frequencies.

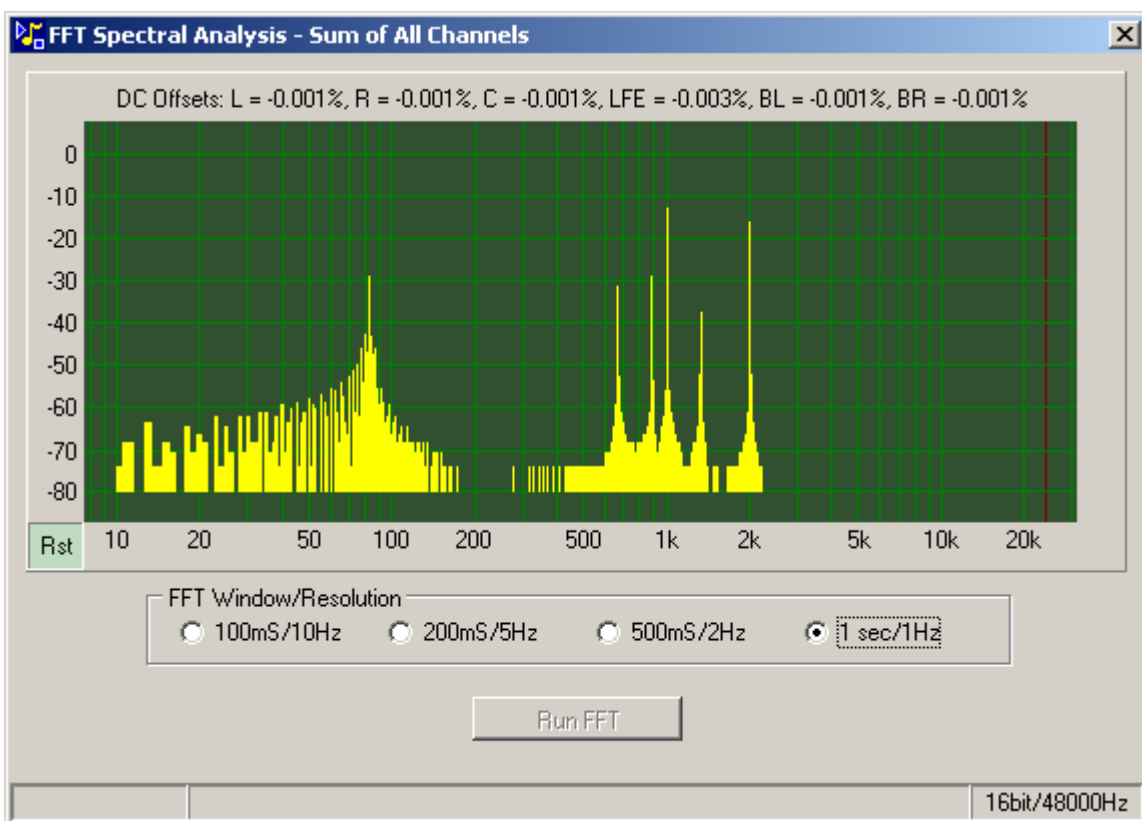

Above the spectral display is a listing of the DC components found on the channels shown as a percentage of peak level.

The horizontal scale runs from 10Hz to half sampling frequency - in this case 24kHz as indicated by the dark red line.

Both the Frequency and Amplitude scales can be changed by clicking on the scales, left-click expands the scale and right-click reduces the scale.

Expanding the horizontal frequency scale will move some of the spectrum out of view, so the plot can be moved sideways by left-click dragging on the spectrum display area. Below is an example of increasing the amplitude scale to be 0.. -100dB and expanding/positioning the frequency scale to show the detail between 500Hz and 2kHz.

The 'Rst' button at the bottom of the amplitude scale resets both the amplitude and frequency scales to their default values.

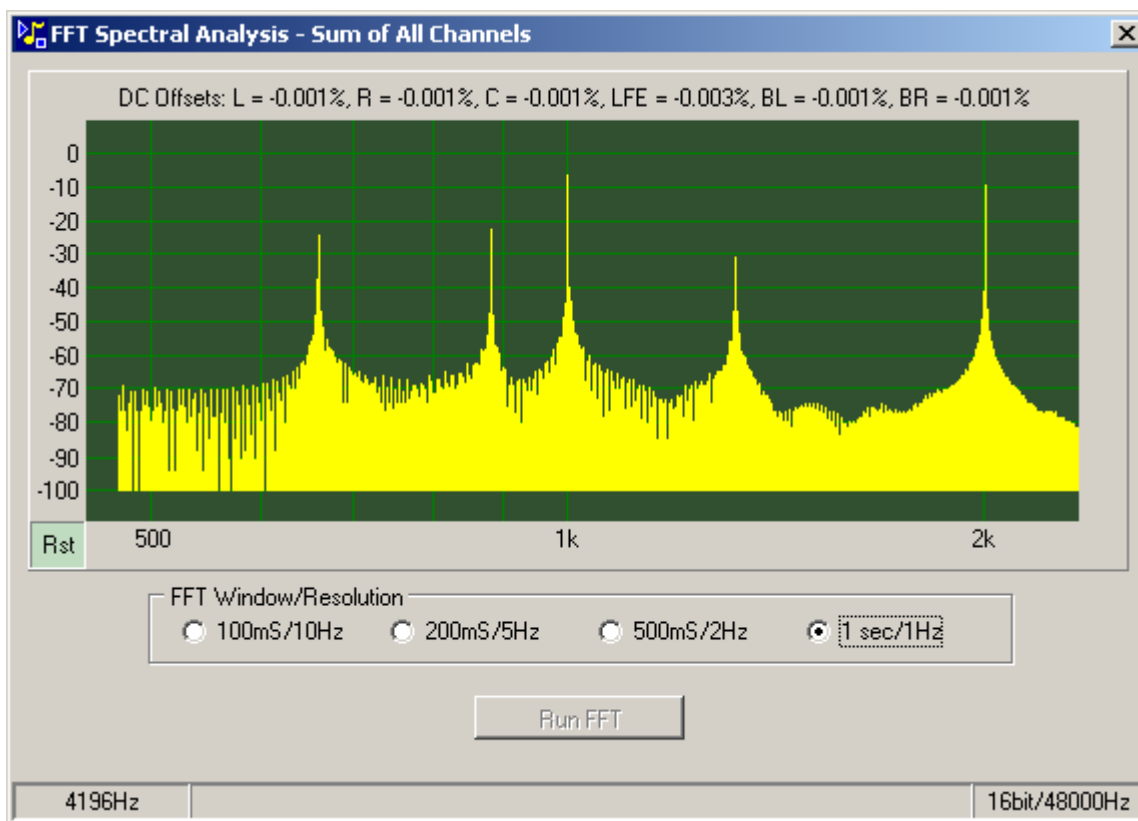

The peak values of the spectrum display may not be what is expected, this is due to the display being a measurement of power so the length of time a particular frequency exists is taken into account.

When the mouse is moved over the graph, the frequency corresponding to the mouse position is shown in the lower left panel of the status bar.

### Floating Position Bar

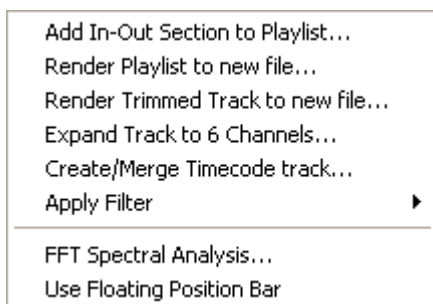

The Use Floating Position Bar option allows ganged control of multiple buttons.

If the button selected is a Master button the ganged operation controls the Master and all Play slaves, if the button is not a Master then controls operate only on that single button.

The Floating Position bar will not control buttons that have an active Playlist, although deselected Playlist In Points can be used as cues.

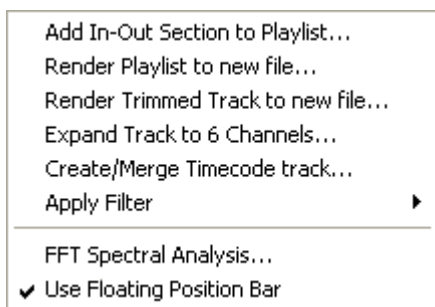

Checking the option and then exiting the Audio Trim page by clicking OK will show a new Floating Position Bar - there is a limit of four Position Bars available.



Here button 1 has been assigned the Floating Position bar which as button 1 is a Master the Position bar will control buttons 1..4 and 11..13, only basic operations of Stop, Play and Cue are available.



Pressing Play on the Position Bar will start all controlled buttons playing and the scrollbar tab will move to show the position within the track, above it is shown positioned 01:08s from the start of the track or Trim InPoint.

If the Slave tracks are not the same length as the Master then they will stop before or after the Master track and the scroll bar will not be a true representation of their position.

While the Master track is stopped it can be cued by dragging the scroll bar tab, below it has been moved back to 00:50s



When Play is again pressed the tracks will play from their new start point.



To assist in cueing a popup menu is available by right-clicking on the timecode readout

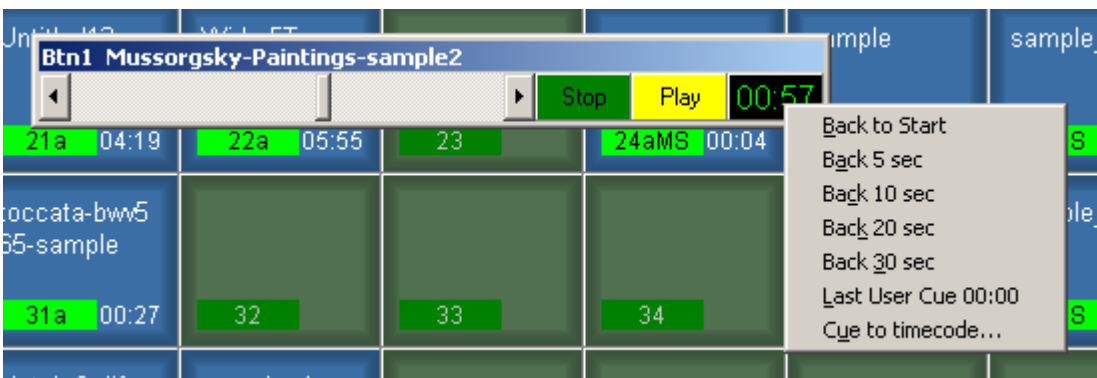

Here there is quick access to the start of the track and cue points at 5s, 10s, 20s and 30s before the point at which the track was stopped

Also any timecode value can be entered by clicking Cue to timecode.

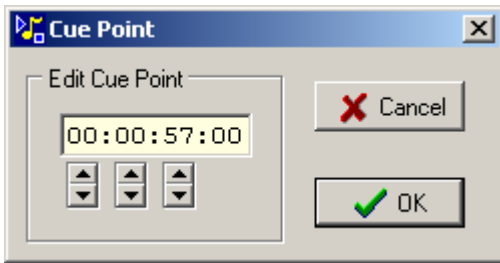

The last value entered into the timecode edit window will be saved as the Last User Cue point

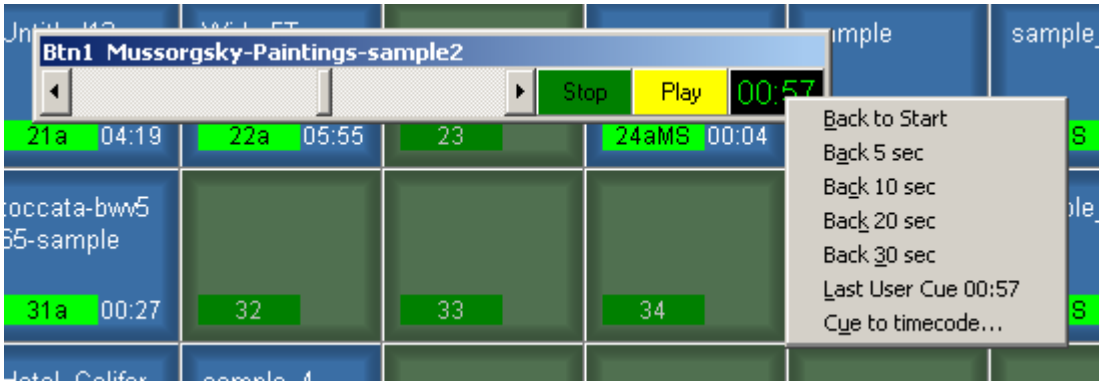

The Play button is shown in white text on a red background when the track is cued up to the start, and in black text on yellow when cued at any other point.

Above it was stated that buttons with active Playlists could not be controlled by Floating Position Bars, however a Playlist can be used as a list of cue points provided all the Playlist items are deselected.

Below is the Playlist page for button 53.

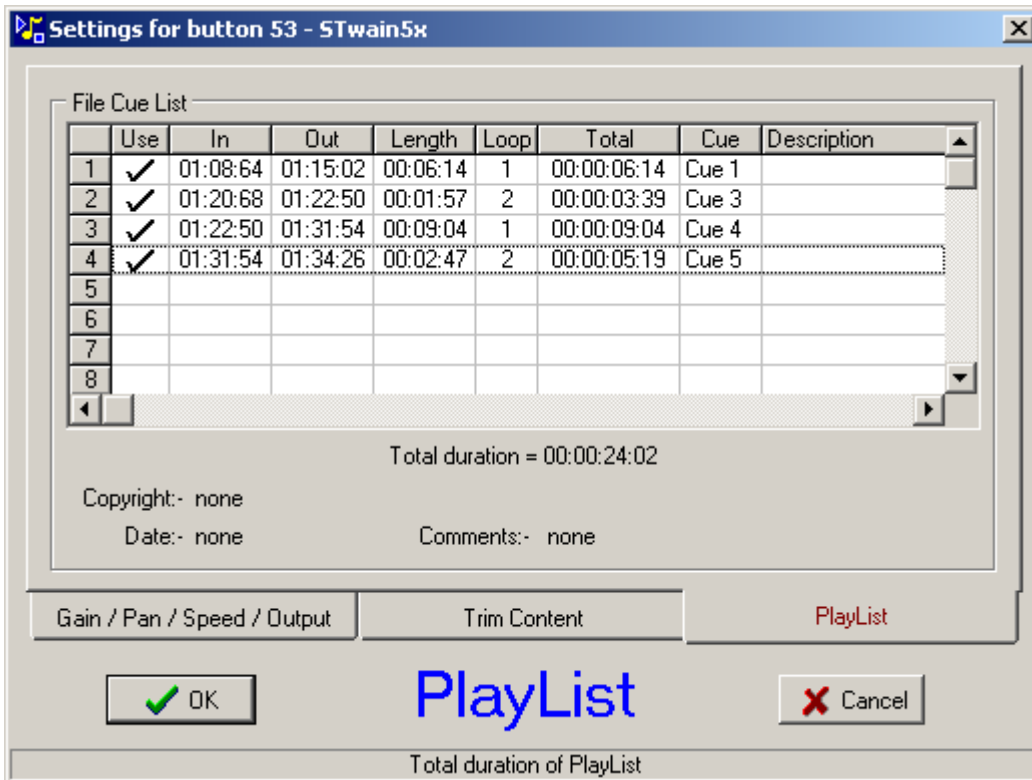

By default the Playlist items will be selected and a Floating Position bar assigned to this button will show the popup menu below with the PlayList cue points disabled - note the cue to Back 5 sec is also disabled, this is because that would be a point earlier than the start of the track

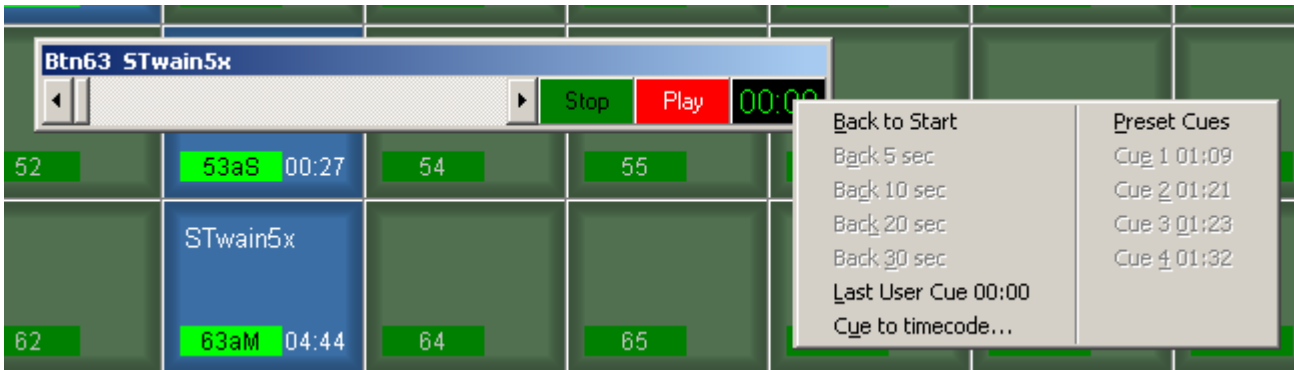

Now if the Playlist items are deselected

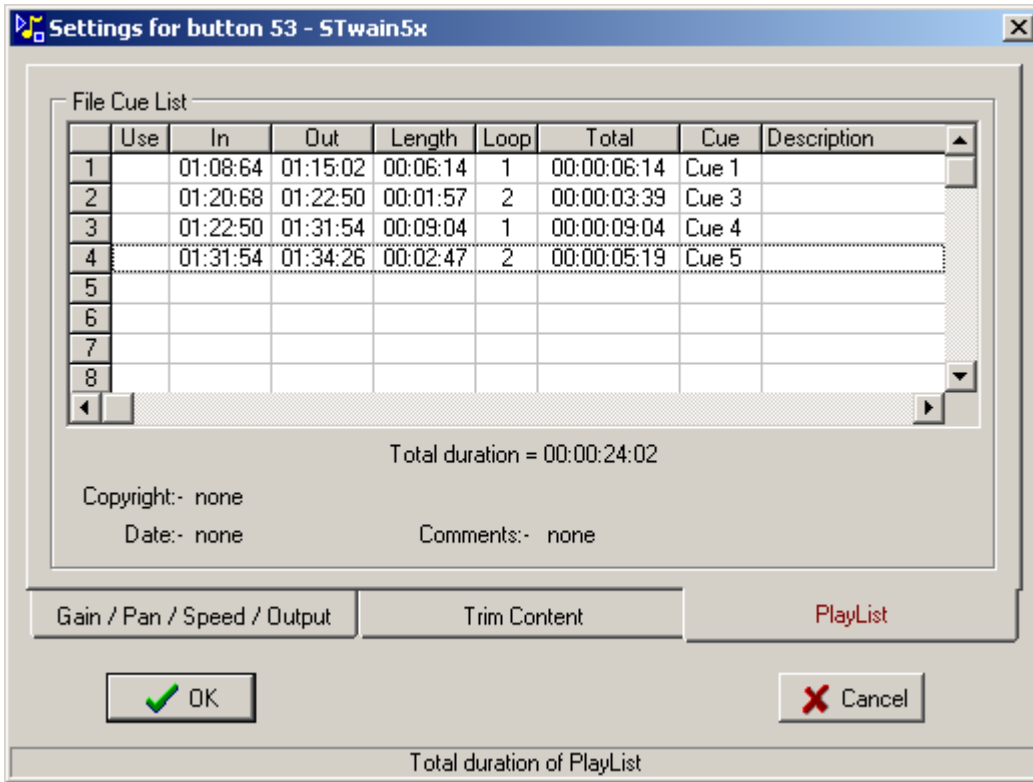

When the popup menu displayed again the Playlist In points are available as cue points, so allowing a track to be prepared with useful cues.

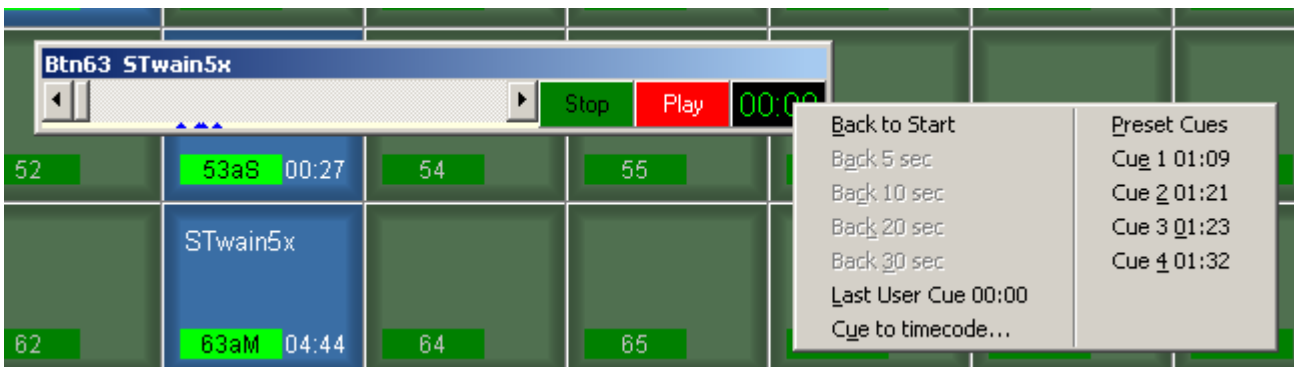

The Preset Cues are marked at the bottom of the scrollbar, below shows the situation after a cue up to Preset Cue 4



As with the Speed bar the Position bar can be resized by dragging the lower right corner of the window.

The Floating Position Bars differ from the other floating bars (Speed and Level) as they are saved in Session and Package files so that they will reappear at their saved size and positions when the session or package is recalled.

Note that the Position Bar does not have the usual Close button on the title bar, the only way to remove the Position bar is to either clear the button or uncheck the 'Use Floating Position Bar' menu item in the Trim window.

# Audio SetUp - PlayList

## PlayList

The WAV file specification allows for PlayLists to be embedded within the file, SpotOn will decode these lists and by default will play out the track following the playlist

A Playlist consists of a list of cues each with an In and Out point, additionally these individual cues can be set to repeat a number of times.

In the example below the playlist has three cues of length 00:68, 01:30 and 01:43, the cues are set to repeat 1x, 5x and 9999x respectively (SpotOn limits the number of repeats to 9999)

Including the repeats gives total durations for each item in the playlist of 00:00:00:30, 00:00:01:18 and 04:22:18:42

Comments, copyright and creation date are also shown if available.

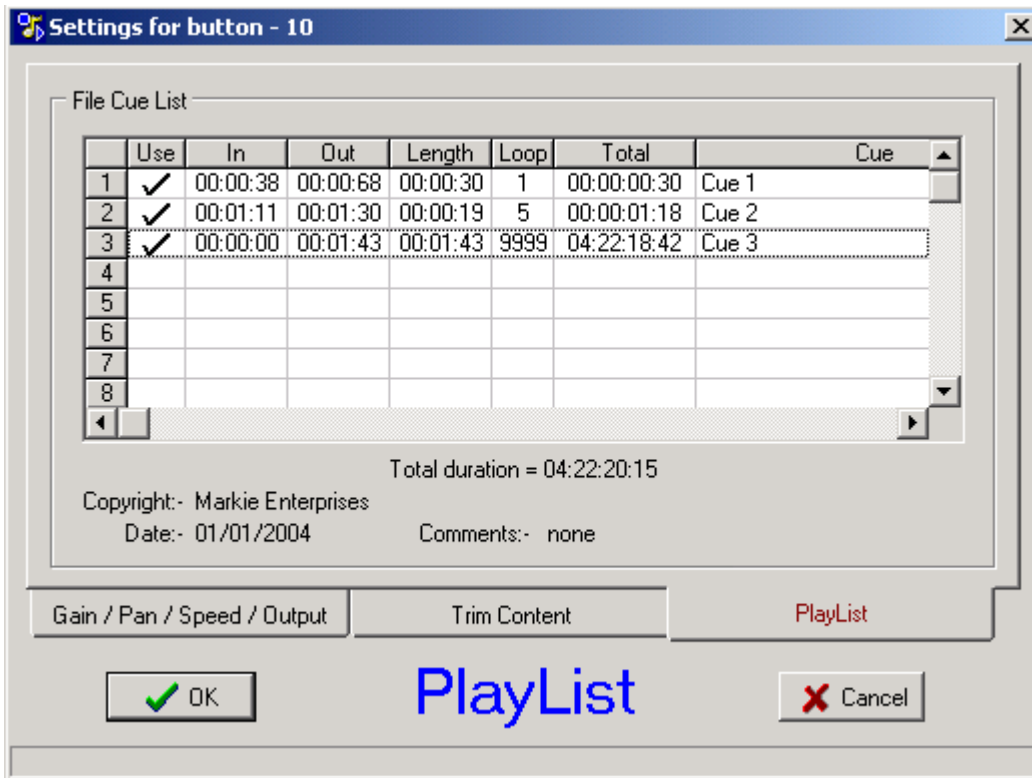

As stated above if a playlist is detected it will be used by default, this is shown by the blue text PlayList at the bottom of the window.

If a subset of the playlist cues are required then they can be individually selected in the Use column, below only the cues 1 and 2 are selected

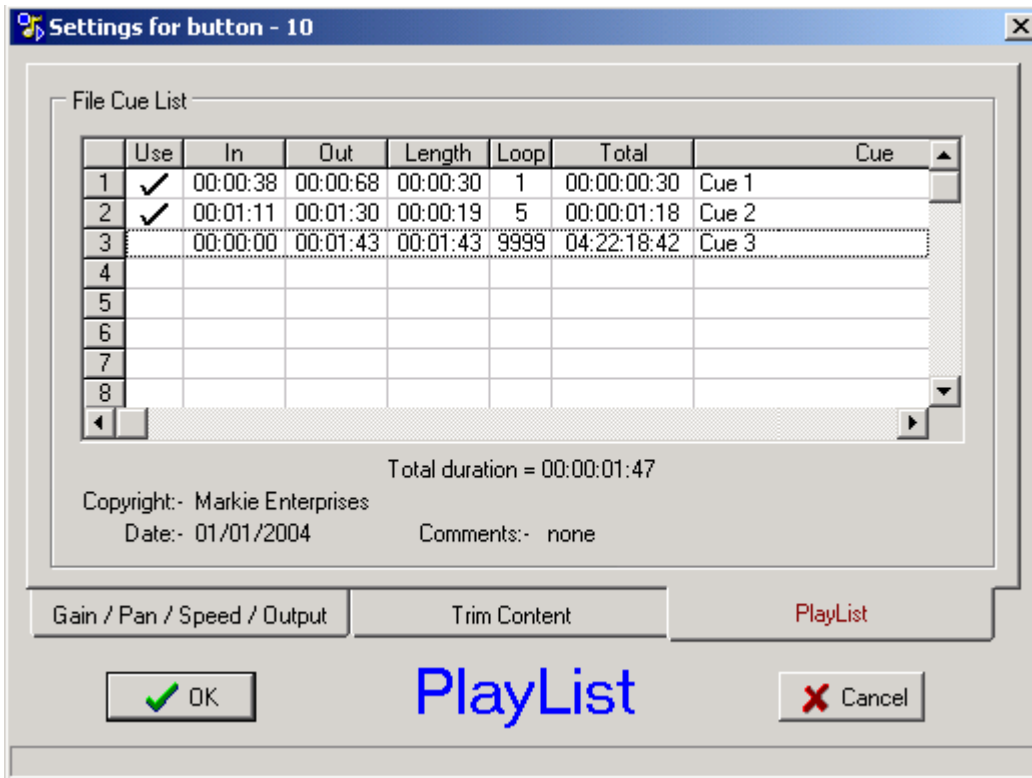

When any cue in the playlist is selected the trim edit page described above is disabled as the cues are effectively predefined

However if all the playlist cues are deselected then the trim edit window is enabled and the playlist is ignored as shown below

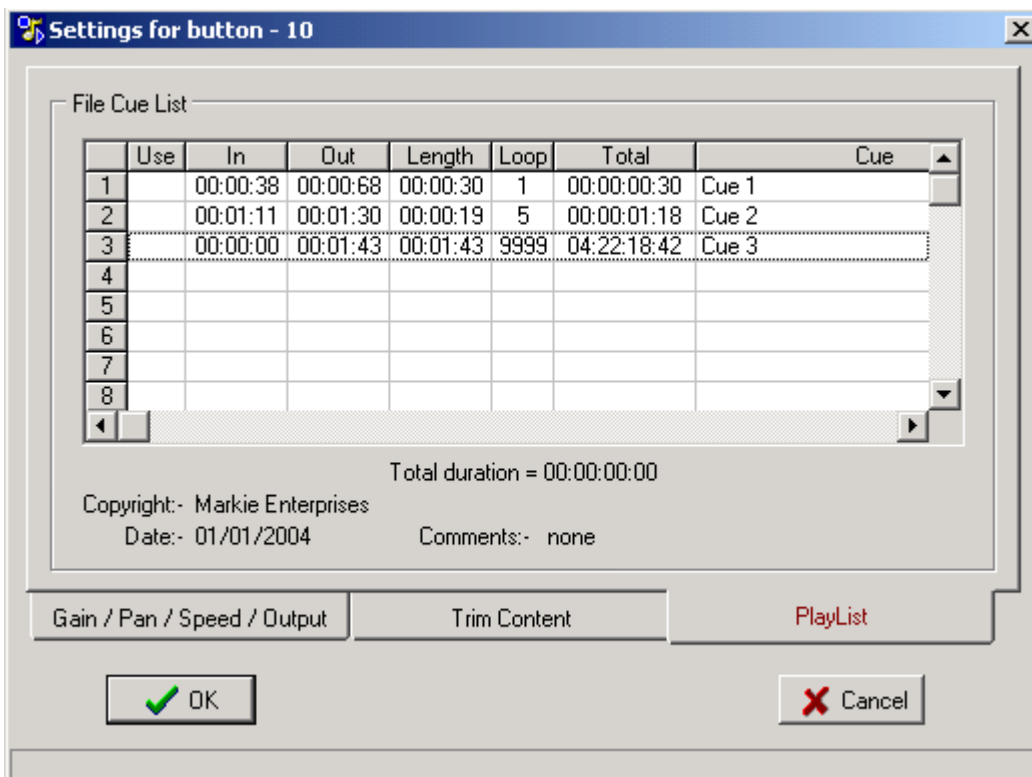

If a button is using a playlist then the duration text is modified with a leading 'P', if the total duration of the playlist is greater than 1 hour the duration is shown as below right

AHH3  
85a P00:02

Basement  
Bed V2  
94a P~:35

The number of loops for each playlist item is shown in the 'Loop' column, this value has been read from the data contained in the WAV file. However, the number of loops can be changed on a per button basis for the duration of the current session by right-clicking the entry in the loop column.

Length	Loop	Total	Cue	Description
00:00:27	1	00:00:00:27	Cue 2	
01:08:00				

The dialog box above allows the loop count to be temporarily changed and affecting only one button, if a permanent change is required then the source WAV file should be edited externally and reloaded into SpotOn

The loop count will be shown in red text if it is different to the values contained in the original WAV file

Length	Loop	Total
00:00:27	7	00:00:02:38
01:08:00	9999	188:51:18:71

The change to the loop count will be maintained across session save/load operations, however if SpotOn detects any change to the Playlist contained within the WAV file then the values will be reset to match the WAV file

If a modified loop count is present then the right-click menu will show an additional item allowing the value to be set to the original value extracted from the WAV file

Length	Loop	Total	Cue	Description
00:00:27	7	00:00:02:38	Cue 1	
01:08:00	999			

Right-clicking on the In column will display the options to cue to the In Point or Cue up and Play from the In Point, this facility is only available when the Playlist item is deselected.

Use	In	Out	Length	Loop	Ti
1	✓	00:00:01	00:03:14	00:03:12	1 00:00
2	✓	00:04:64	00:12:27	00:07:39	9999 20:52
3	✓	00:			1 00:00
4					
5					
6					

	Use	In	Out	Length	Loop	Ti
1		00:00:01	00:03:14	00:03:12	1	00:00
2		00:04:64	00:12:27	00:07:39	9999	20:52
3		00:	Cue to In		1	00:00
4			Play from In Point			
5						
6						

# Midi Assignment

Selecting the Midi option from the button popup menu displays the dialog box below, here the incoming Midi notes that causes the button to play or stop can be set along with the outgoing Midi note that is sent when the button starts to play or stops.

Below is the default setup with no Midi In and no Midi Out notes selected, the range for Midi notes is 0..127 and for Midi channels 1..16.

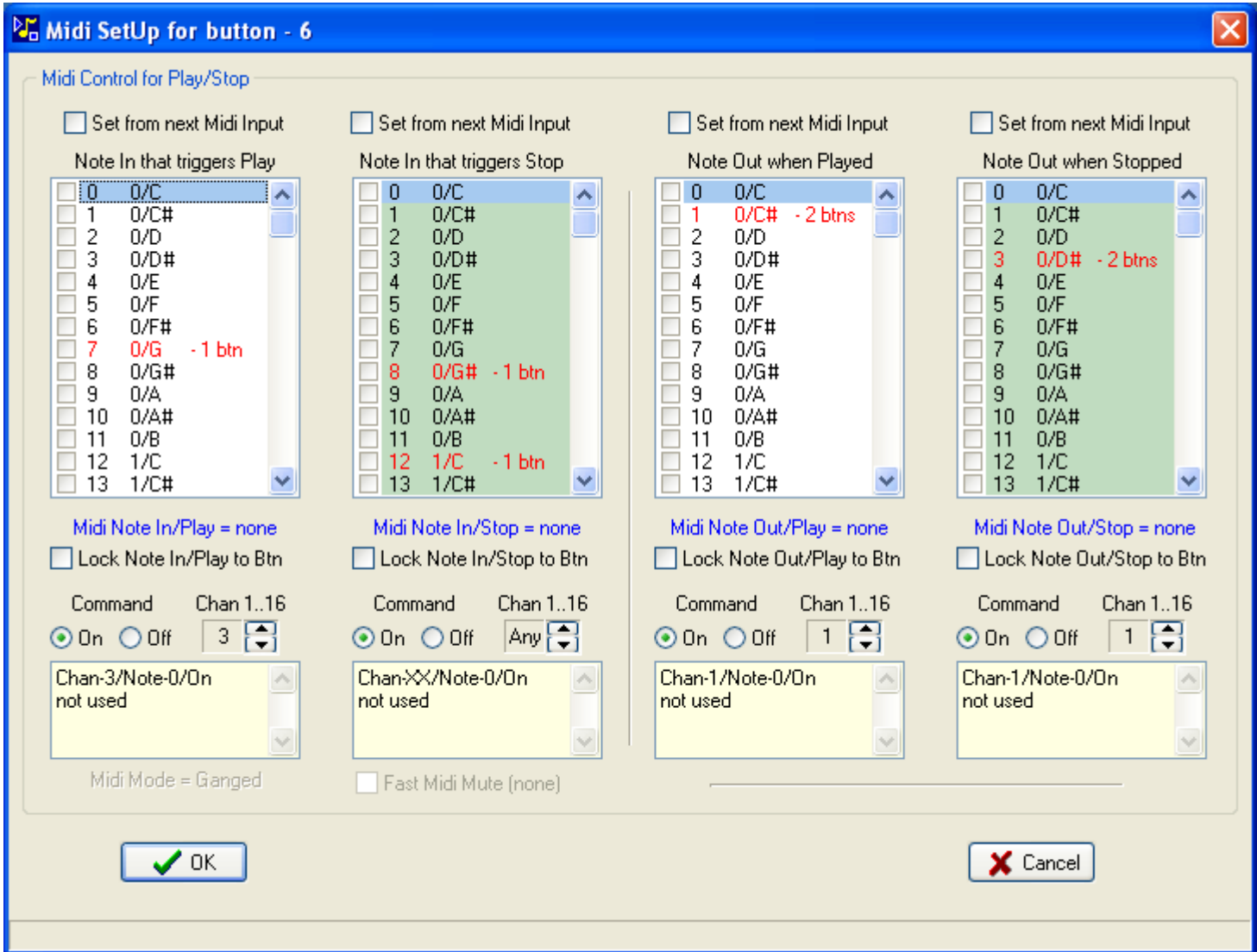

There are four sections in this dialog:-

- Left            Note In that triggers Play
- Left Centre   Note In that triggers Stop
- Right Centre   Note Out sent when button is Played
- Right           Note Out sent when button is Stopped

**N.B.** The Midi Note out on Stop is not triggered when tracks are stopped via - Escape, Page Stop, All Stop or a fade out "Stop All on Play"

Separate notes can be set for the Midi In/Play, Midi In/Stop and Midi Out/Play and Midi Out/Stop actions, the full specification of the selected note is shown below the list, eg "Midi Note In/Play = 1/20/On" translates into Channel 1, Note 20, Note On

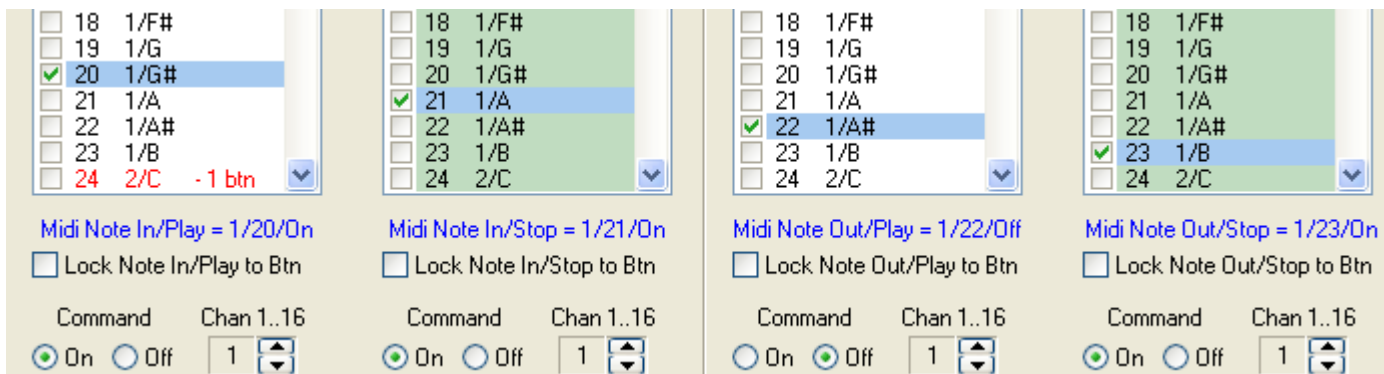

If other Midi notes on the same Midi channel are used by other buttons, then the note entry will be shown in red text along with the number of other buttons using the note

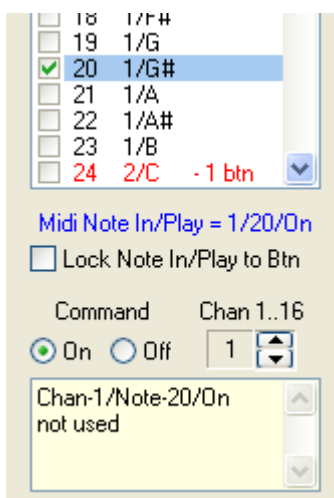

Selecting the notes without checking them reveals any other buttons that may be using the same Channel/Note/Action combination

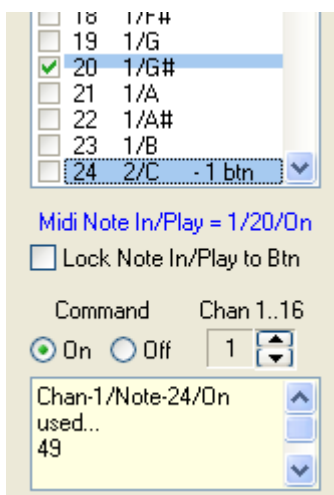

The Lock Note check boxes allow the Midi settings to be permanently assigned to the selected button, so that which ever track is loaded onto the button the Midi settings remain.

The original settings of any track transferred to a button with the Lock Note enabled are saved and will be restored when the track is moved off the Lock Note button.

The Midi Note In and Out actions can be tested by right-clicking any note and choosing Test Midi In or Out as appropriate.

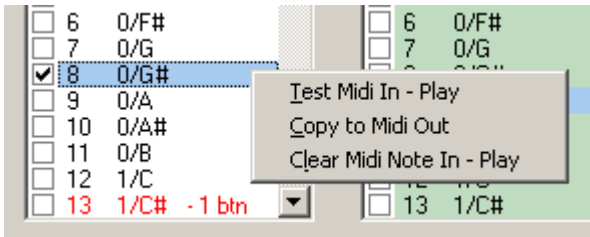

Midi In/Play



Midi In/Stop

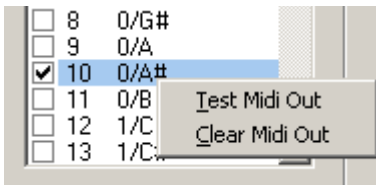

Midi Out/Play

Default Midi Out Velocity/Volume is set to 127 (maximum).

Also the Midi In/Play selection can be copied to the Midi Out column by clicking the popup menu option, if the Midi In channel is set to 'Any' then the note copied to Midi Out will retain the existing channel number otherwise it will take the Midi In/Play channel number.

The Midi In and Out functions can be individually enabled/disabled either via the [Options|Midi Control](#) menu item, or by clicking the Midi status panels at the bottom of the main window.



The text in the status panel will briefly flash red when an incoming Midi signal is detected or an outgoing Midi signal is generated

Buttons that have either Midi In or Midi Out assignments can be designated by additional icons

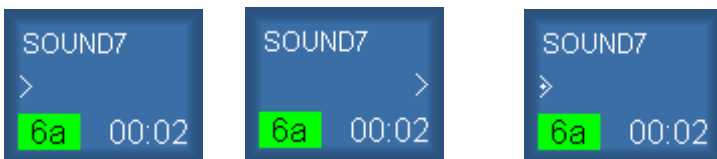

These are enabled via the main menu [Display>Show Midi InOut](#) option

The "Set from Next Midi Input" checkboxes at the top of the three columns allow the Midi notes to be automatically set from the next Midi note to be sent to SpotOn. This allows the Midi notes to be set without the possible confusion of Midi note/channel numbering.

Set from next Midi Input

In some circumstances there is the need to use very fast Midi On/Off sequences eg 80mS on and 50mS off, the Fast Midi Mute option redirects the Midi notes On/Off to be UnMute/Mute. The mute action is much faster than continually stopping and restarting a track.

For this option to work the track has to be looped

Fast Midi Mute (90mS)

A typical example of use would be a sensor on a rotating wheel in a game show that produces Midi On/Off notes whose length and spacing changes with the speed of the wheel.

As the track is looped, the output will be unmuted between receiving a Midi Note On message and a subsequent Midi Note Off message, in some circumstances this is not desirable so it is possible to set a maximum unmuted timeout by right clicking the checkbox above and selecting the appropriate duration. Selecting none disables the timeout feature.

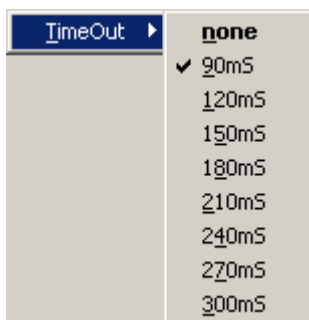

# Regions

Most button menu options only apply to one button at a time, Regions allow actions to be performed with multiple buttons.

There are two types of Region - a Source Region and a Target Region, these are indicated by yellow/black and red/black chequer patterns respectively as shown below.

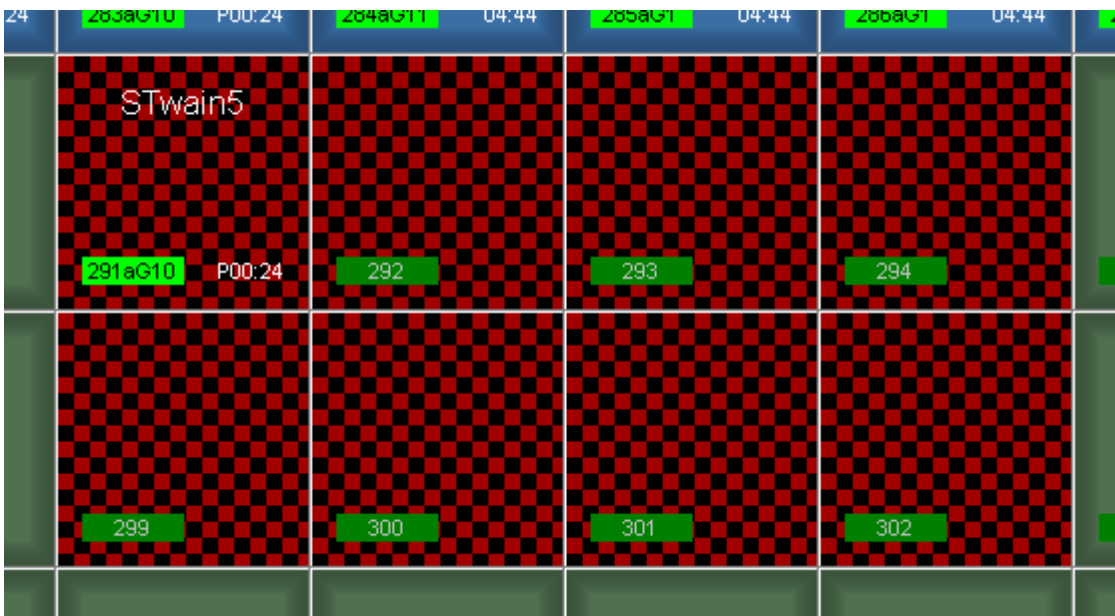

## Source Region

The source Region is defined by holding down the left Alt key, depressing the left mouse button and dragging the mouse to select a rectangular block of buttons.

Right clicking a button in the source Region displays a Region popup menu

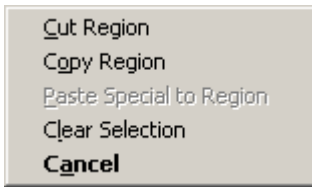

The Cut, Copy and Paste Special actions refer to the whole selected source Region, in this example 8 buttons.

The Paste Special option works as described in [Edit|Paste Special](#) for a single button but in this case is applied to all buttons in the source Region.

## Target Region

The target Region is defined by holding down the left Alt key, depressing the right mouse button and dragging the mouse to select position of the target buttons.

The target Region is always the same layout as the source Region in this case 2 rows by 4 columns, this region cannot be positioned to overlap a page edge, but it can be dragged to any position on any page by dragging over the page name tabs

The Target Region also has a right click menu

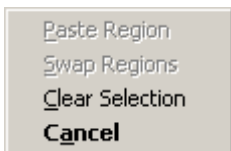

The Paste and Swap actions refer to the whole selected target Region and are only enabled when the source Region has been copied to the clipboard.

## Multiple Selections

An additional facility is available when selecting source regions allowing a non-contiguous region of buttons to be highlighted.

This is achieved using the Ctrl+Alt+left click action which will toggle the button in/out of the source region selection. This method of selection can also be used to define the tracks to be [burned to CD](#)

~:52	2aGA X@00:02	3aGA P~:56	4aG1 01:16	5aG1 02:07	6a
	Ronan1	Eric Prydz ◆ Q	Belinda - Heaven - Guide K	Trombone Stab > 0/44	Er C
~:52	10aG1 04:18	11aG1 P~:52	12aG2 02:00	13aG1 X@00:03	14
5 5	1kHz_16_44 _AB_M8	Trombone Stab	Eric Prydz > E	Eric Prydz > E	E
0:07	18aG5 00:20	19aGA 00:02	20aG2 P~:56	21aG2 P~:56	22
	1kHz_16_44	Eric Prydz -	Eric Prydz -		E

The Region selection highlighting can be cleared via the right click popup menus or by pressing Escape - note pressing Escape will also stop all tracks that are playing.

# Additional Information

[Keyboard and mouse Shortcuts](#)

[Windows Sounds](#)

[Advanced Operation](#)

[USB Power](#)

[UDP/TCP Commands](#)

[EmBER+ Control](#)

[PBus Control](#)

[Locked Attributes](#)

[Button Icons](#)

[Command Line Switches](#)

[Settings](#)

[XML Playout Logs](#)

[Screen Saver](#)

[Sound Card Mixers](#)

[Audio Processing](#)

[Decoders](#)

[Audio File Types](#)

[Bits Ident](#)

[MultiChannel](#)

# Keyboard Shortcuts

## Global

Scroll Lock (double-press)    Switch input focus to SpotOn main window

## Main Window - Normal mode - global

Ctrl + B	Burn tracks to CD
Ctrl + F	File Search Utility
Ctrl + G	GPI SetUp
Ctrl + H	Play Stack
Ctrl + L	Show Global level meters
Ctrl + M	Master/Slave Links setup
Ctrl + O	Load Session
Ctrl + R	Refresh Tracks
Ctrl + S	Save Session
Ctrl + T	Toggle Elapsed/Remaining time display
Ctrl + U	Reset Tracks Played flags
Ctrl + Y	Redo change
Ctrl + Z	Undo change
PageUp	Move next page tab
PageDown	Move to previous page tab

## Main Window - Normal mode - on buttons

Left click	Play button under mouse pointer
Right click	Either stop track or open button Menu
Centre click	**Pause track
Centre click	**Skip playlist item
Double click	On an unassigned button opens load window
Alt + Double click	On an unassigned button opens load with Top/Tail window
Centre + Right click	**Open button menu
Shift + Right click	Open button Menu
Ctrl + Right click	Open HotKey assignment
Shift + Ctrl + Left press	Query master/slave links to/from button
Shift + Ctrl + left drag	Drag and drop new link from master to play slave
Shift + Ctrl + Right click	Open Group/Output assignment window
Spacebar + Left click	When step to next is disabled will emulate mouse centre click -
Alt+Drop	Loads button after Auto Trimming track
Alt + left drag	Define contiguous source region (yellow)
Alt + right drag	Position target region (red)
Ctrl + Alt +left click	Define non-contiguous source region
Left Shift + left Alt + Left click	Preview button play
Alt + Ctrl + Shift + left drag	Drag and drop colour between buttons

\*\* selectable options

### **Main Window - Normal mode - on Button popup menu**

Shift + Left click on Stop All on Play	Stop Page on Play
Ctrl + Left click on Stop All on Play	Stop on Mouse Up

### **Main Window - Normal mode - on status bar**

Right click on Midi In/Out, GPI, Links & HotKeys	Highlight buttons
Shift + Left click on GPI In panel	toggle PBus control on/off
Shift + Right click on GPI In panel	display SMPTE timecode nudge options

### **Main Window - HotKeys enabled**

F1..F12	Play button with assigned HotKey
A..Z	Play button with assigned HotKey
Numpad 0..9	Play button with assigned HotKey
Qwerty 0..9	Select page

### **Main Window - Step To Next enabled**

Up,Down,Left & Right Arrow	Position Step to Next cursor
Home	Position Step to Next cursor top left
End	Position Step to Next cursor bottom right
Alt+Home	Position Step to Next cursor to

### **Audio Window - Gain/Pan/Speed/Output page**

Up,Down,Left & Right Arrow Change value, when Gain, Pan or Speed focussed

### **Audio Window -Trim page - general**

Spacebar	Play/Pause track if not a playlist
----------	------------------------------------

### **Audio Window -Trim page - waveform display**

Left click	Mark In point
Right click	Mark Out point
Centre click	Cue track to position
Shift+Left click	Cue track to position

### **Audio Window -Trim page - Fade In/Out displays**

Left click drag	Change fade times
-----------------	-------------------

### **Audio Window -Trim page - Trim In/Out values**

Shift + Left click	Mark In/Out Point
Qwerty I	Mark In Point
Qwerty O	Mark Out Point

### **Audio Window -Trim page - Time remaining display**

Right click	Rehearse out point
-------------	--------------------

# Windows Sounds

Windows produces sounds as a result of certain activities such as emptying of the Recycle Bin, these sounds are not disabled by selecting 'No Sounds' in the Windows Control Panel|Sounds and Audio Devices|Sounds|Sound Scheme.

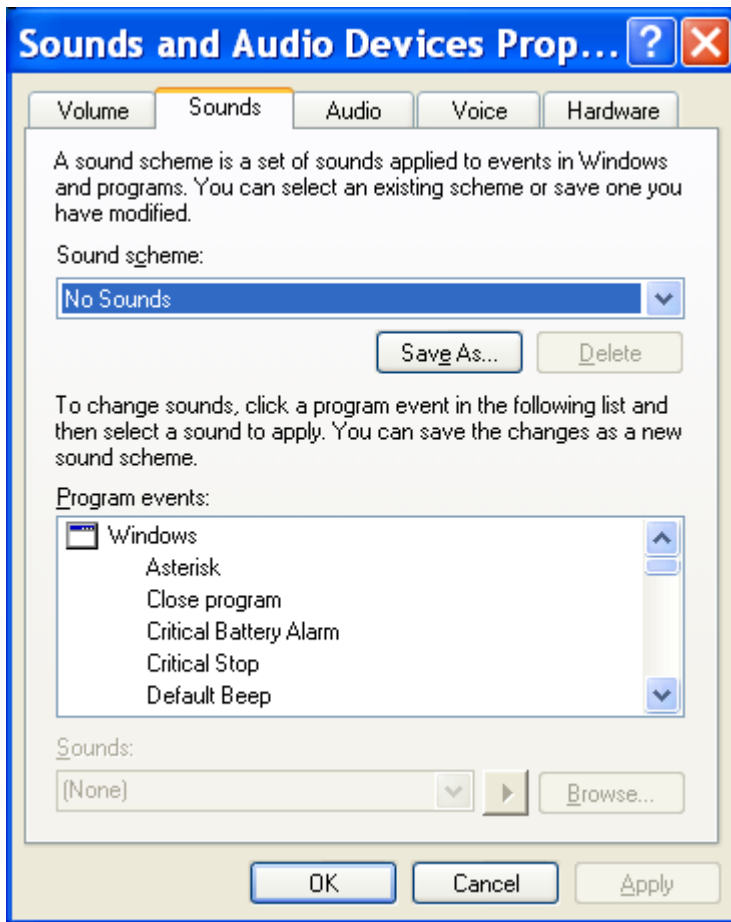

However, another way of disabling the computer 'Beep' is via the Control Panel|System|Device Manager.

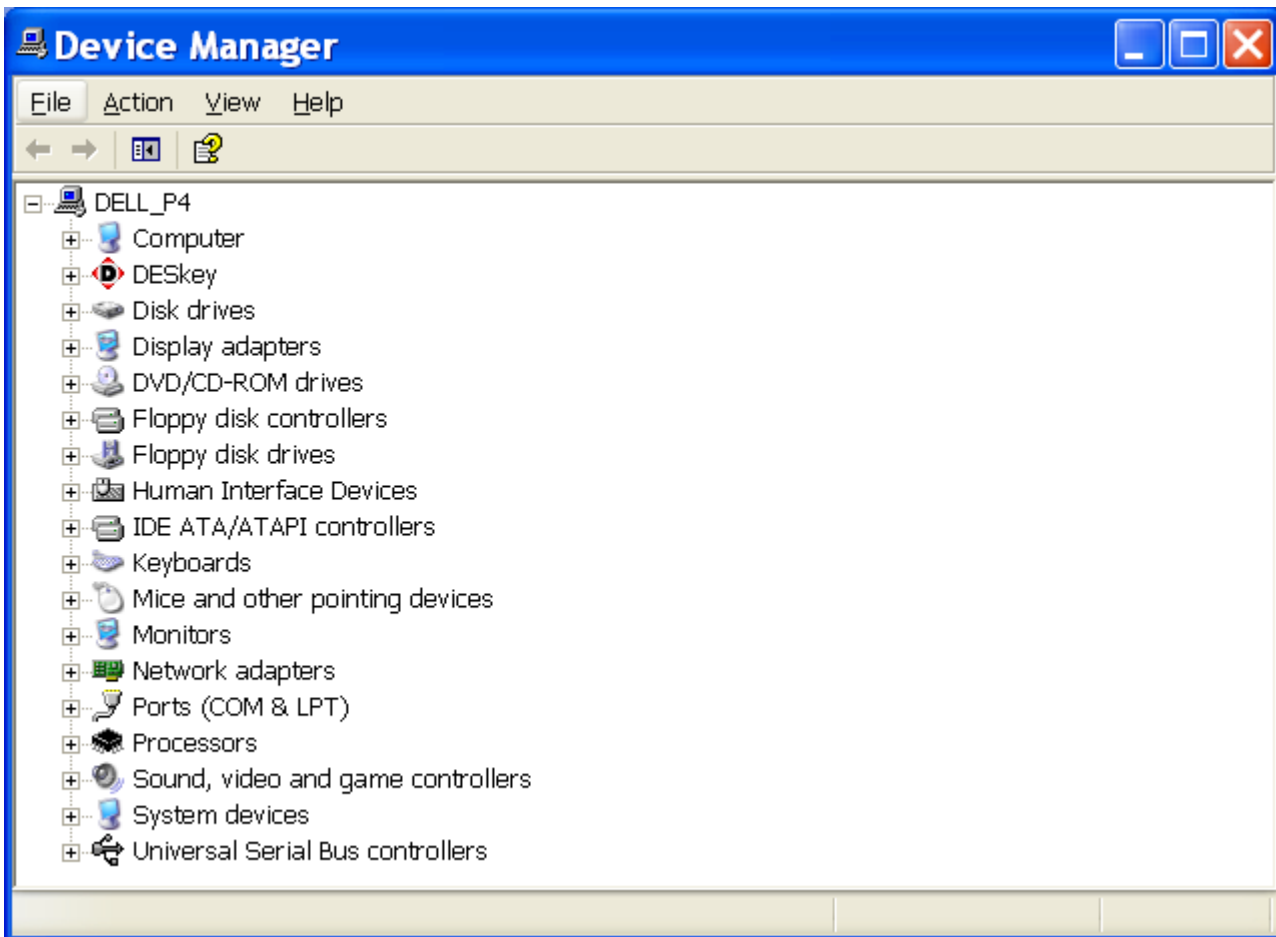

Select 'Show Hidden devices' from the View menu

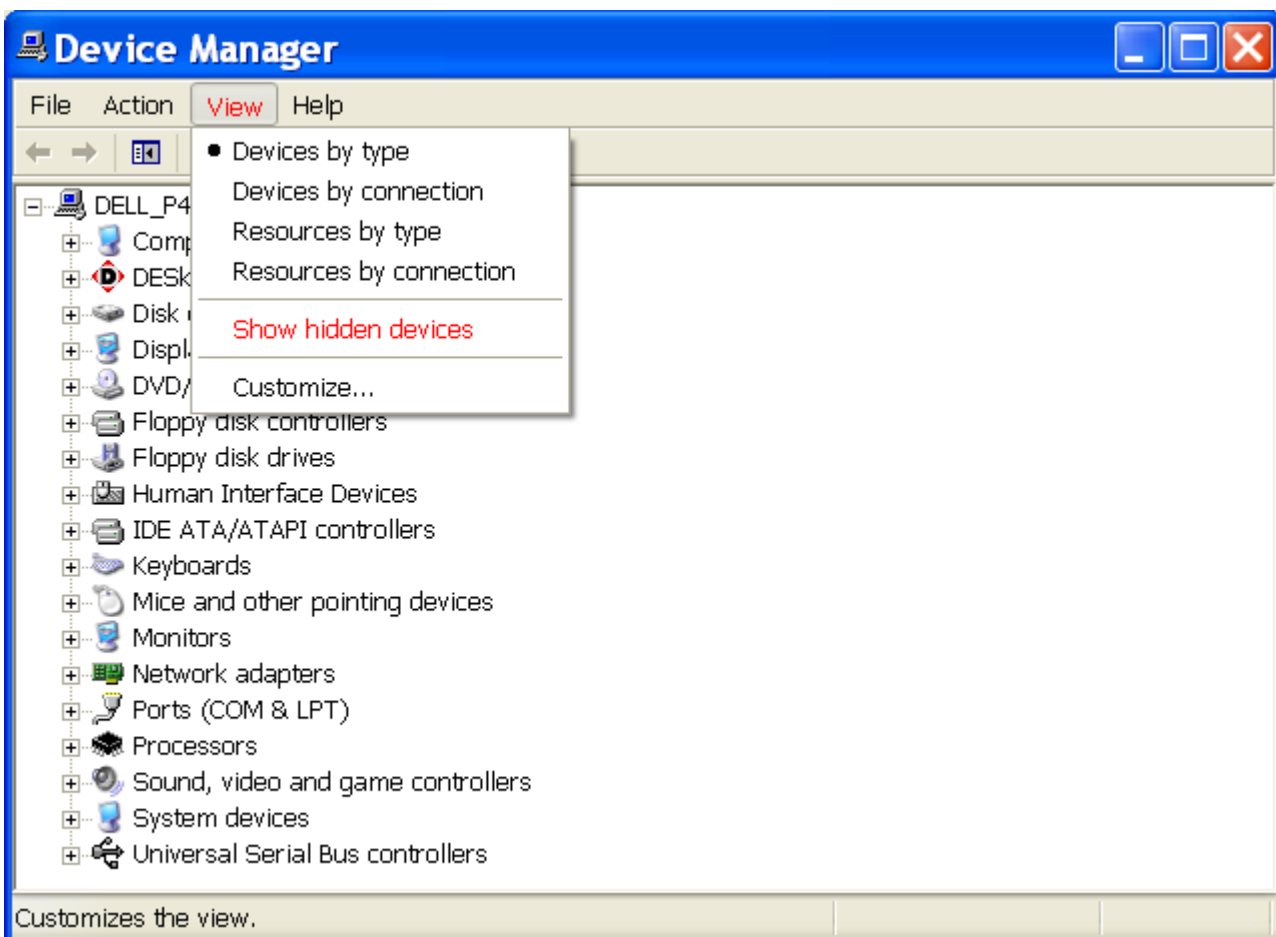

A new entry titled Non-Plug and Play Drivers will appear, open this tree and select 'Beep'

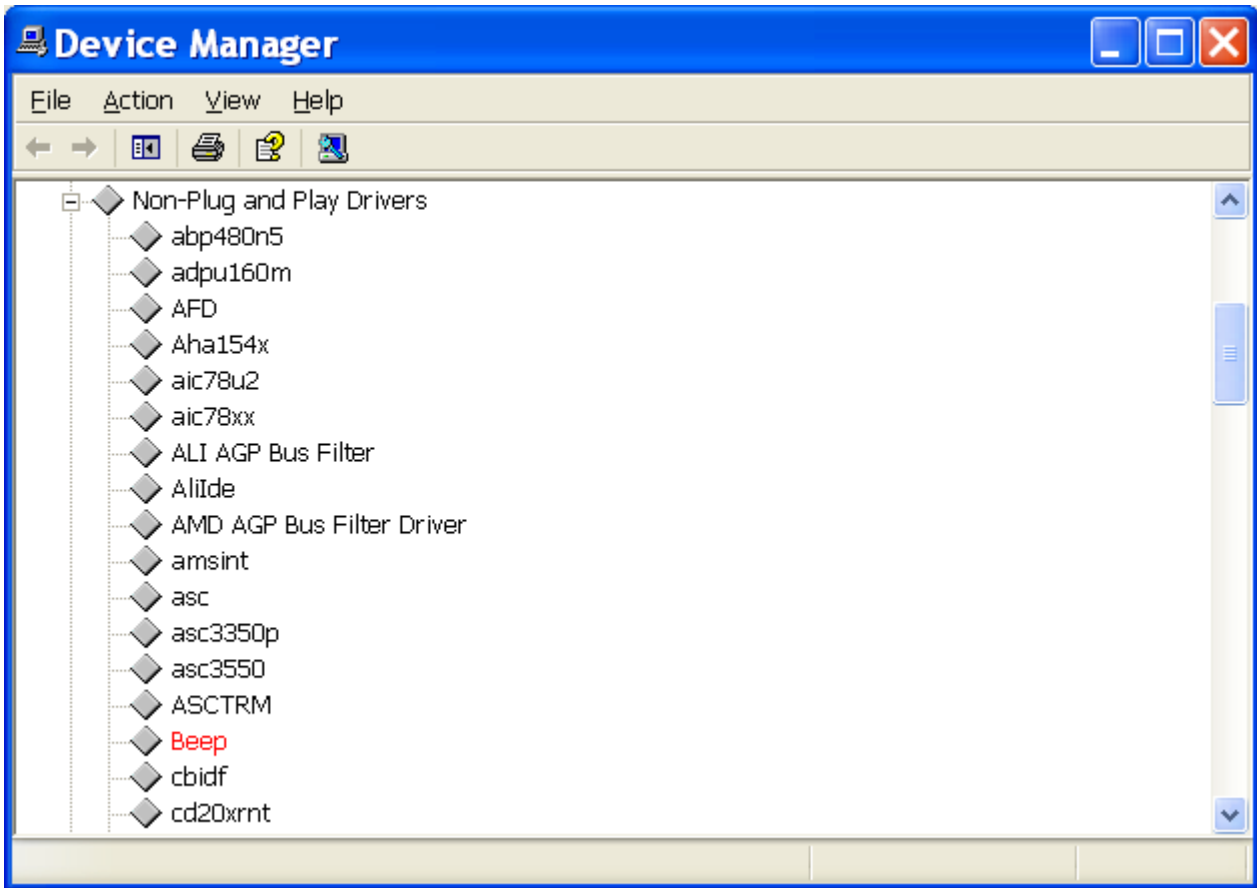

Choose the Driver tab in Beep properties and click the Current Status 'Stop' button

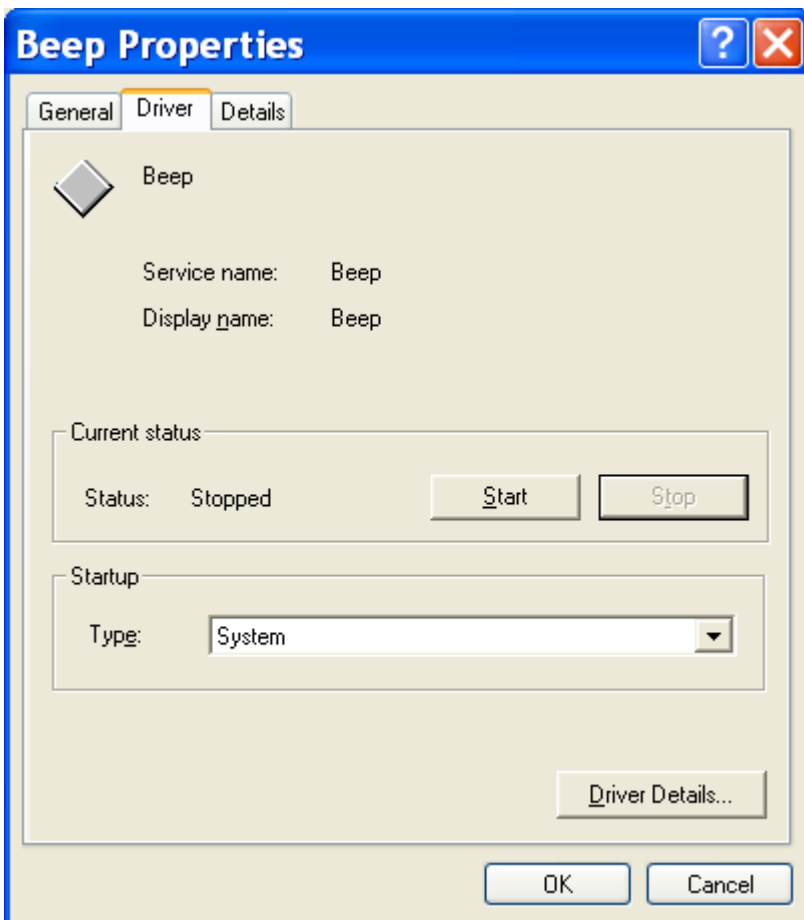

Finally set the StartUp mode to be disabled instead of System

# Beep Properties



General Driver Details



Beep

Service name: Beep

Display name: Beep

Current status

Status: Stopped

Start

Stop

Startup

Type: Disabled

Driver Details...

OK

Cancel

# Advanced Operation

## Blocks, Sessions and Packages

These types of files can be loaded via the File menu items, additionally SpotOn will accept Block (\*.blk), Session (\*.dta) and package (\*.pkg) files that are 'dropped' onto the application after being 'dragged' from Windows Explorer.

Also package and session files can be dropped onto a SpotOn desktop icon, the application will then open and load the dropped file.

## Package Folder Structure

Packages contain session data and audio in one composite file, when extracted all the audio files will be copied to the chosen folder. The disadvantage of this is that any folder structure that may have originally existed would be lost when the package was extracted.

For example if the folder structure below existed in the original session, with audio files in the myBeds, myFx and myMusic folders

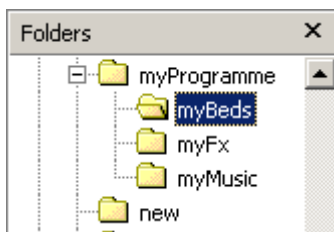

and then a Package file made from the session and subsequently extracted onto another computer into the newProgramme folder, the structure would be:-

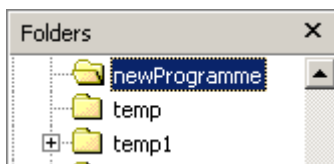

The myBeds, myFx and myMusic subfolders have been lost as all the audio has been extracted to the newProgramme folder.

To avoid this there is a 'magic' folder name "SpotOnAudio" which if present in the file path of the audio files ensures that any subfolders of SpotOnAudio will be preserved.

So if the original session was build using something like the example below and then saved as a package...

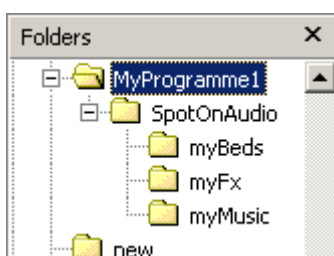

When the package is extracted to the newProgramme1 folder, the subfolder structure is maintained

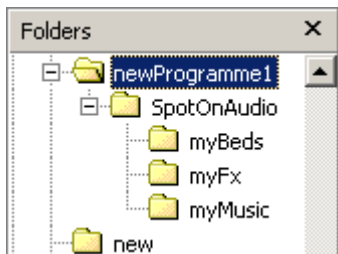

## PlayLists

A Playlist consists of predefined cues played out in sequence with the option of repeating each cue number of times.

Below are the details of a Playlist containing 3 cues

	Use	In	Out	Length	Loop
1	✓	00:00:38	00:00:68	00:00:30	1
2	✓	00:01:11	00:01:30	00:00:19	9999
3	✓	00:00:00	00:01:43	00:01:43	1
4					

Cue 1 is played once followed by cue 2 (effectively looped indefinitely) and then finally to cue 3 to end the sequence.

This type of Playlist can be used as a basis for the Intro-Loop-Outro type of sequence, however the main problem is that the time cue 2 has to loop for is unknown at setup time - depending on some external events.

To cover this situation there is a method of forcing SpotOn to step on to the next Playlist entry, so if Cue 2 was looping and was on loop 125 the program can be triggered to complete loop 125 and then step onto cue 3.

Cue 3 would play to the end and stop.

Users with a three button mouse or a mouse with a scroll wheel can click the middle button/scroll wheel to trigger the effect. in this case the currently playing cue in the Playlist will complete one final loop then step onto the next cue in the Playlist.

Note: normally the middle button click would pause/unpause a track, but as Playlists cannot be paused, the same key combination has been used to trigger starting the next playlist section at the end of the current loop/pass.

When the button receives the message it will briefly flash the Track Number text to red on yellow

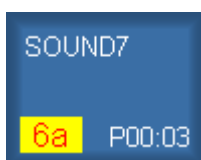

Immediately after the message has been received the Track number text reverts to its Playing color and the time remaining text will appear underlined

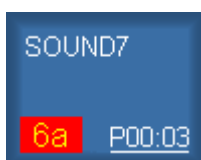

## HotKeys

The scope of the HotKeys can be either Global or Paged, set with the selection box shown below.

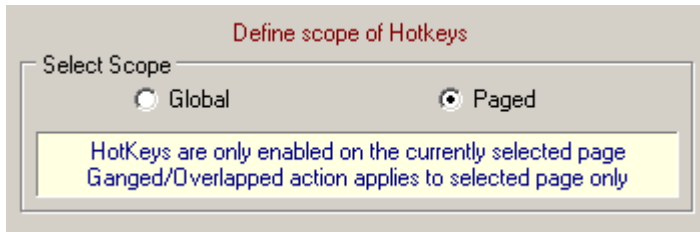

When Global is selected the HotKeys are enabled on all pages and with Paged HotKeys are only enabled on the currently selected page.

When more than one button is assigned to the same hotkey there are two modes of behaviour - Ganged and Overlapped.

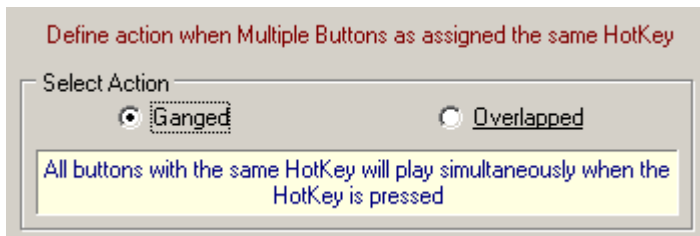

In the ganged mode all buttons that have the same hotkey will be played together at the same time, this is similar to a simple form of [master/slave link](#).

In the overlapped mode the operation is a little more complicated, this mode is intended to cover the situation where the same sound is required to be played several times at random intervals with subsequent sounds starting before the previous sound has completed.

A typical example is a two chime door bell where the bell is sounded twice in quick succession, the decay on the second chime must be allowed to continue when the bell is sounded again, so this precludes the playing of the same button as this would terminate the decay.

In the example below Overlapped Mode causes the pressing hotkey 'Z' to initially play button 35, if the sound is allowed to stop a further press of the hotkey will again play button 35.

If however the hotkey is pressed before the sound has stopped the next available button with the same hotkey will be played, in this case button 36.

So providing the sounds to be played are relatively short e.g. 1..3 seconds a group of 5 or 6 identical buttons should suffice.



The Ganged/Overlapped setting applies globally to all hotkeys.

Overlapped operation can be triggered in a similar way by Midi In messages and also via mouse left-click.

With mouse left-click the overlapped mode is only active when the following conditions are met: -

- 1, duplicate hotkeys are assigned to buttons
- 2, hotkeys are enabled
- 3, hotkey text is showing on buttons Display|Show Hotkey Text
- 4, overlapped hotkey mode is selected

Then left-clicking on any of the buttons on the overlapped hotkey group will cause the overlapped play action to start.

## Midi

The scope of the Midi In Play messages can be either Global or Paged, set with the selection box shown below.

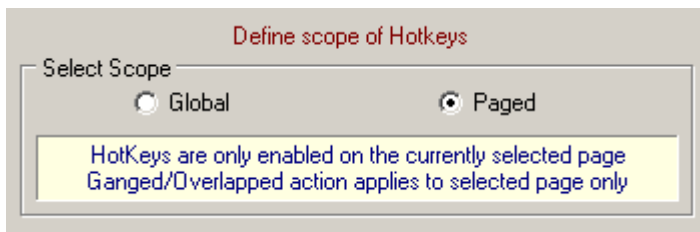

When Global is selected the Midi In Play messages are enabled on all pages and with Paged they are only enabled on the currently selected page.

When more than one button is assigned to the same Midi In Play message there are two modes of behaviour - Ganged and Overlapped.

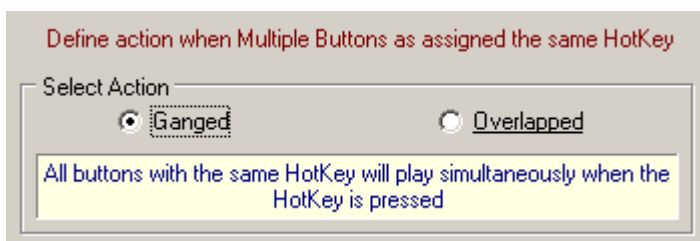

In the ganged mode all buttons that have the same Midi In Play message will be played together at the same time, this is similar to a simple form of [master/slave link](#).

In the overlapped mode the operation is a little more complicated, this mode is intended to cover the situation where the same sound is required to be played several times at random intervals with subsequent sounds starting before the previous sound has completed.

A typical example is a two chime door bell where the bell is sounded twice in quick succession, the decay on the second chime must be allowed to continue when the bell is sounded again, so this precludes the playing of the same button as this would terminate the decay.

In the example below Overlapped Mode causes the sending Midi In Play message 'Z' to initially play button 35, if the sound is allowed to stop a another Midi In Play message 'Z' will again play button 35.

If however the Midi In Play message is sent before the sound has stopped the next available button with the same Midi In Play message will be played, in this case button 36.

So providing the sounds to be played are relatively short e.g. 1..3 seconds a group of 5 or 6 identical buttons should suffice.



The Ganged/Overlapped setting applies globally to all Midi In Play messages.

# USB Power Management

The Windows XP operating system has the ability to control the amount of power supplied to the various USB ports, this only becomes a problem with SpotOn when the power to the USB dongle is switched off.

To check the USB port power settings open Windows Control Panel and select System, then on the Hardware tab select Device Manager. Scroll to the bottom of the device list to display the entry 'Universal Serial Bus Controllers'.

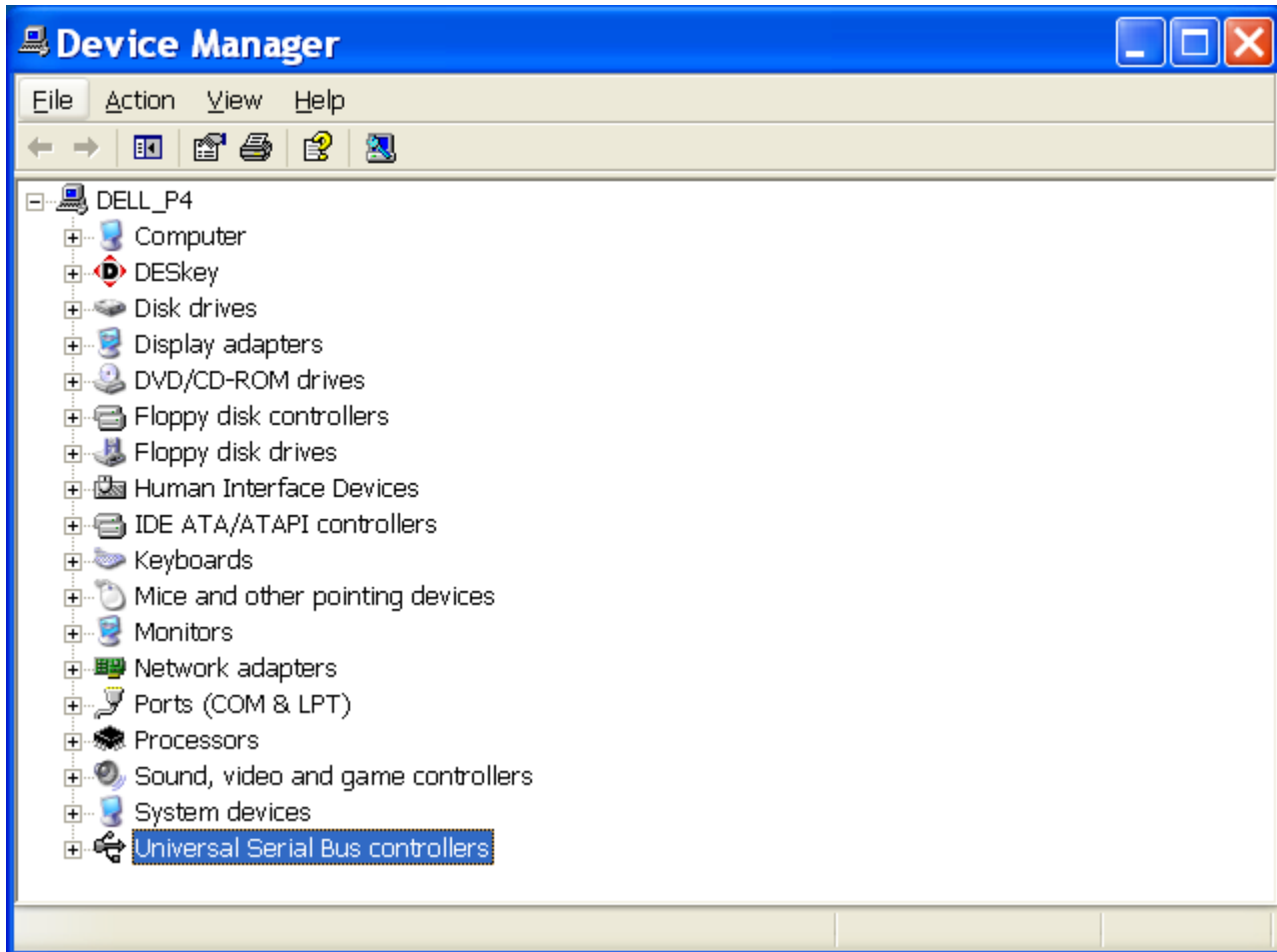

Open the 'Universal Serial Bus Controllers' item

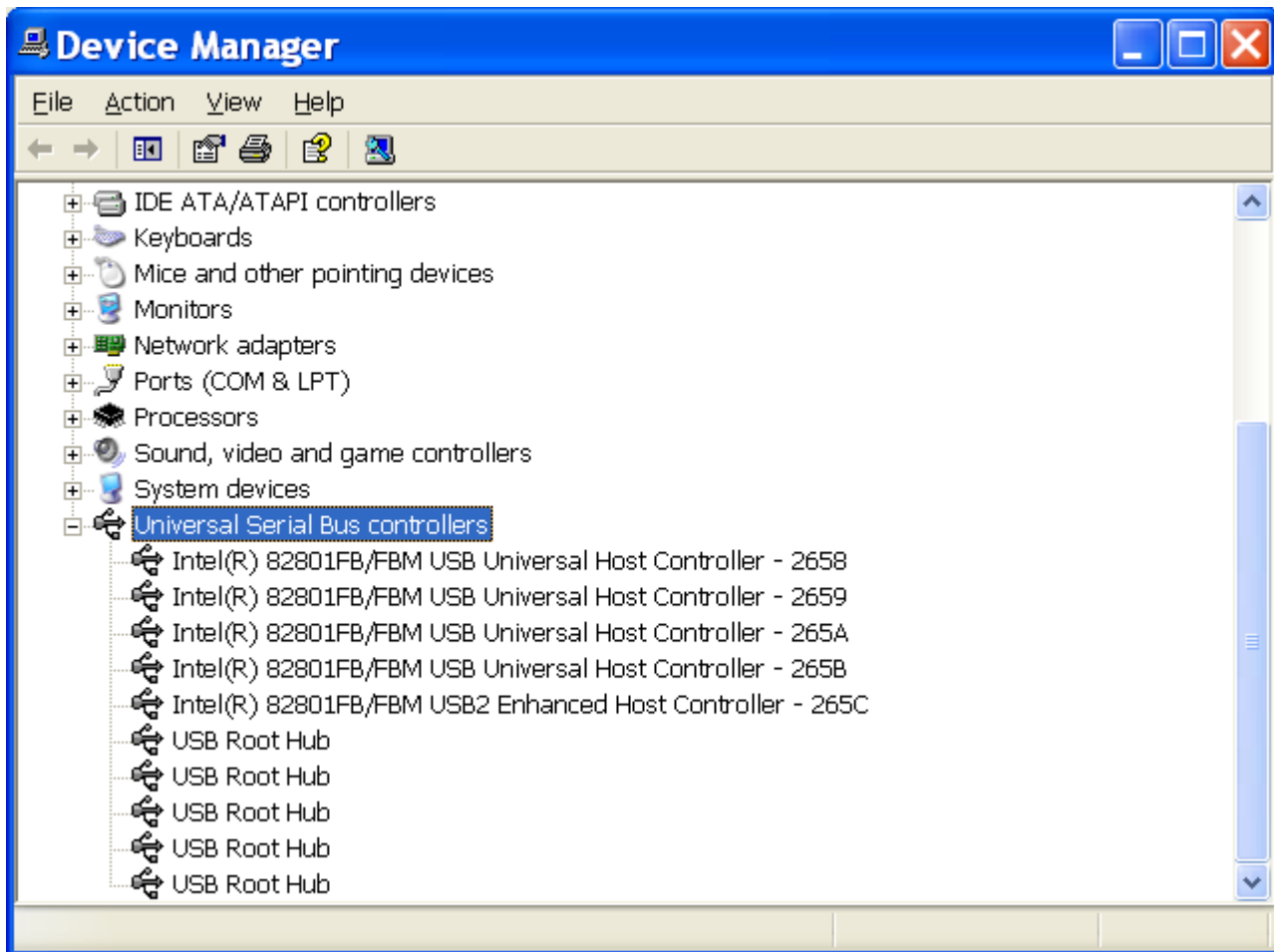

Now select each of the USB Root Hub entries in turn and open up the associated Power Management tab

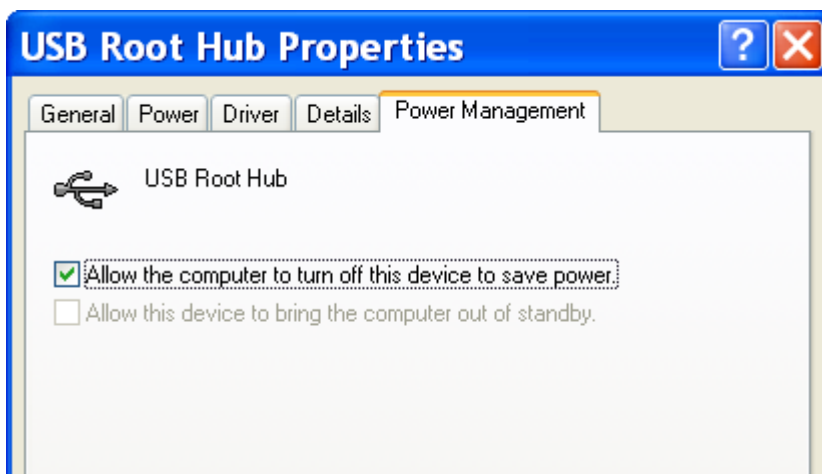

Uncheck the 'Allow the computer to turn off this device to save power' option



Make this change on all USB hubs to which a SpotOn dongle could be fitted, this is to cover the situation where the dongle is removed and placed in a different USB port.

It is possible to identify which port has the USB dongle fitted by examining the details on the Power tab.

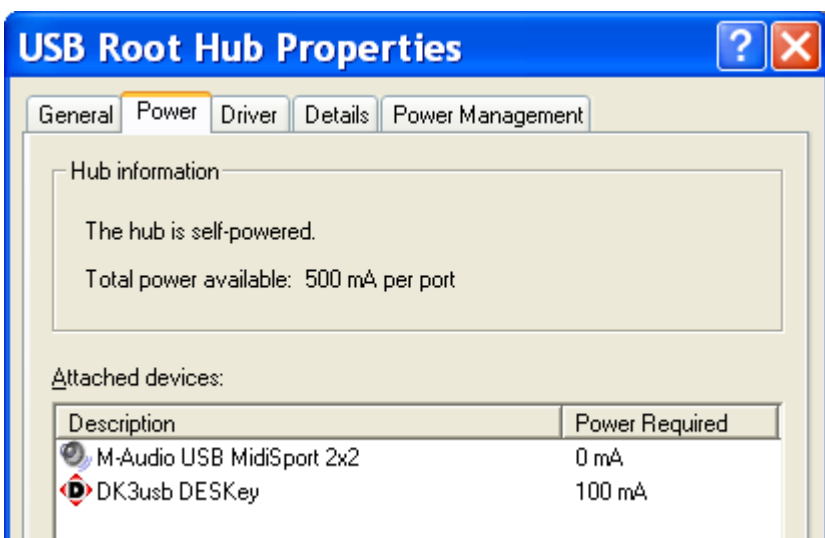
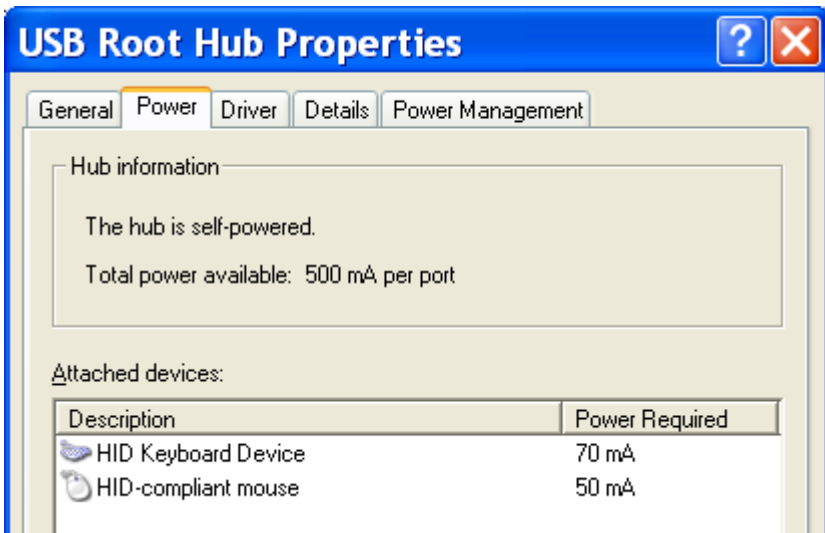

# Game Port Connections

## Joystick/GPI

The conventional Game Port found on most Sound Cards is a 15 pin D-type socket, to use the Fire buttons as GPI inputs make the connections as described below

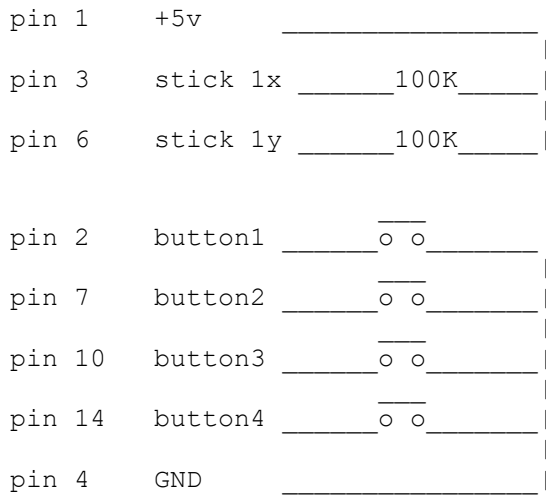

## Soundcard

- 
- 1 : +5vDC
  - 2 : Stick 1 button 1
  - 3 : Stick 1 X-position
  - 4 : Gnd
  - 5 : Gnd
  - 6 : Stick 1 Y-position
  - 7 : Stick 1 button 2
  - 8 : +5vDC
  - 9 : +5vDC
  - 10 : Stick 2 button 1
  - 11 : Stick 2 X-position
  - 12 : MIDI
  - 13 : Stick 2 Y-position
  - 14 : Stick 2 button 2
  - 15 : MIDI

Take care with the routing of the +5v supply as this may not be current limited on the sound card

A suggestion below consists of two cables a D15M..D9F that remains connected to the PC and a loose cable D9M..(4 x jack plugs) that connect to the GPI sources.

The advantage of this is that the two resistors on pins 3/6 of the D15M are always connected to the PC, and so avoids the situation where the GPI device is inadvertently disconnected, causing SpotOn to poll for a non-existent 'joystick'.

As an alternative to using two leads the 2 x 100K resistors could be mounted directly on the GPI card connector pins inside the computer, this should only be attempted by those with suitable experience.

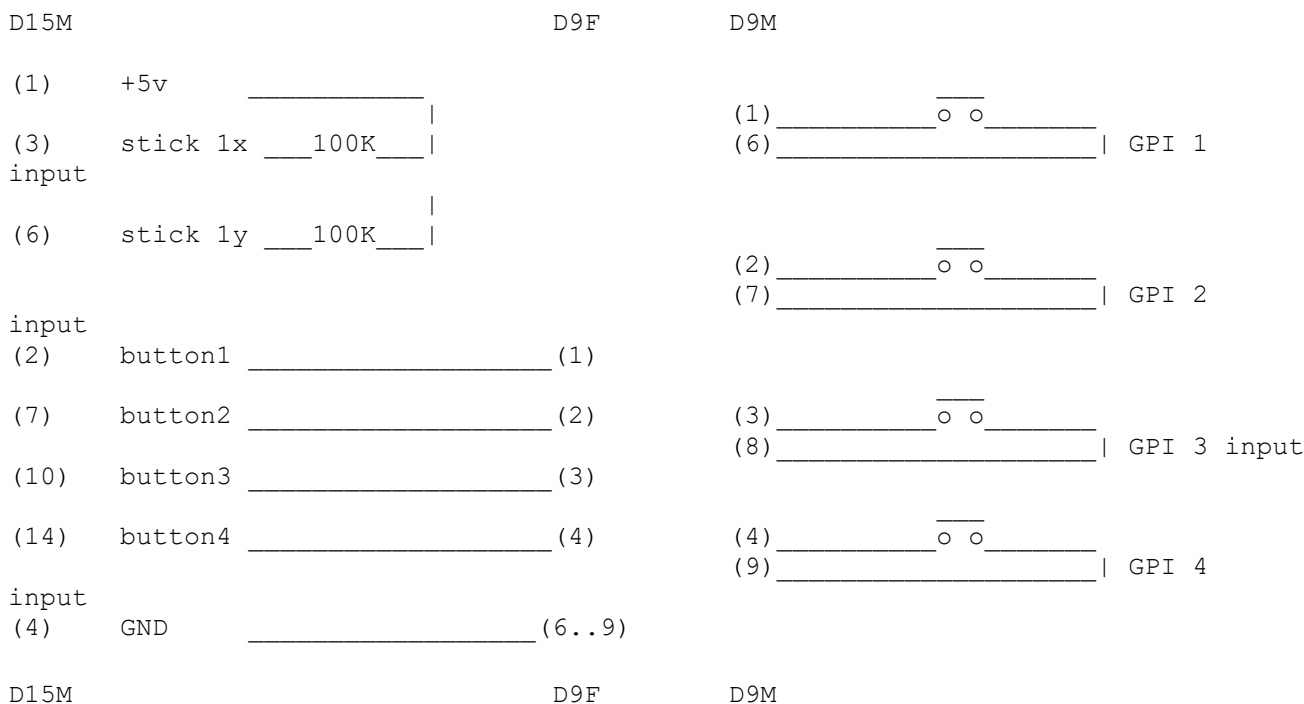

It is recommended that some form of protection is applied to the sound card inputs an Opto or Relay isolated interface would be suitable.

Alternatively a USB joystick can be used to provide the GPI inputs, in this case slightly more work will be required to extract the button signals from the joystick, but the internal wiring of such devices is usually simple.

## Midi

Game ports on many computers support Midi In/Out, the signals on the 15 way game port connector are not suitable for direct connection to a Midi device.

The diagram below from the [Midi Manufacturers Association](#) shows one interfacing method

### Computer Sound Card Game Port to Standard MIDI Connector

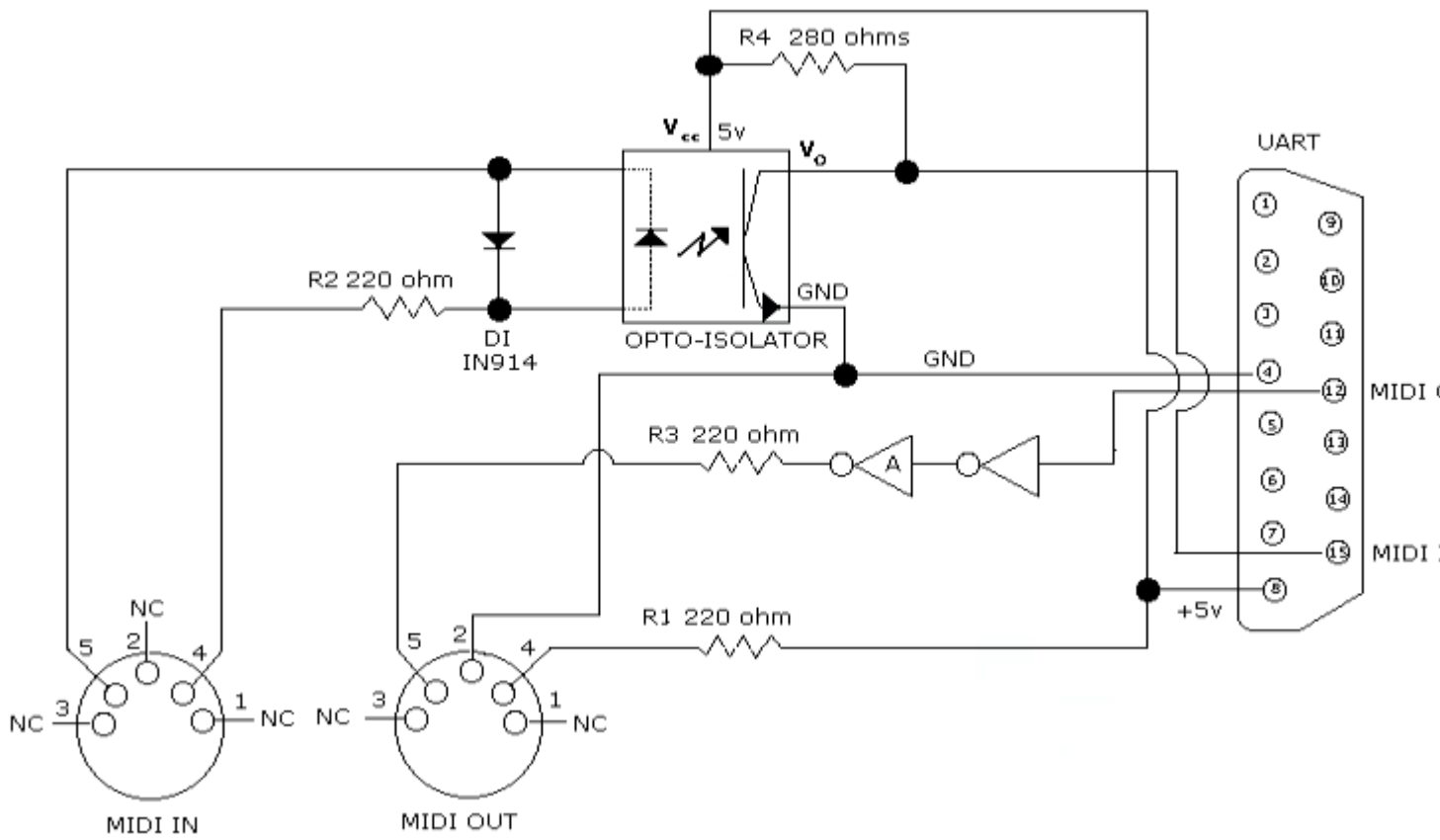

# UDP/TCP Commands

## Control via UDP/TCP

SpotOn can respond to messages passed to the computer running SpotOn via a UDP or TCP connection, the message protocol is defined below.

SpotOn will listen on UDP/TCP port 4650 for proprietary commands listed below and also on port 4700 for a subset of OSC (Open Sound Control) commands.

<a href="#">Midi</a>	Midi messages via UDP
<a href="#">Cues</a>	Play and Stop tracks by name
<a href="#">List</a>	List track names
<a href="#">Note</a>	List Midi notes assigned to buttons
<a href="#">Errors</a>	Error codes
<a href="#">OSC</a>	OSC commands
<a href="#">PlainText</a>	Formatted text commands
<a href="#">EmBER+</a>	Open standard control protocol

## Midi Commands

The message format consists of 8 bytes (0..7)

Bytes 0..3 form the header

Byte 0 = 'M'  
Byte 1 = 'I'  
Byte 2 = 'D'  
Byte 3 = 'I'

Bytes 4..6 form the data

Byte 4 = Midi Status  
Byte 5 = Midi Data1  
Byte 6 = Midi Data2  
Byte 7 is a checksum of bytes 0..6 modulus 0x100

(Note On, Note Off, All Notes Off and All Notes Stop are the only commands implemented)

SpotOn will reply with a message of the same format

Bytes 0..3 form the header

Byte 0 = 'M'  
Byte 1 = 'I'  
Byte 2 = 'D'  
Byte 3 = 'I'

Bytes 4..6 form the data

Byte 4 = Reply code  
Byte 5 = not used  
Byte 6 = not used  
Byte 7 is a checksum of bytes 0..6 modulus 0x100

Reply code can take the values:-

Error_None	0	message received correctly
Error_UnRecognisedHeader	1	header bytes not recognised
Error_BadHeaderChecksum	2	checksum byte in header does not match calculated checksum
Error_BadData	3	Message data invalid format
Error_NotEnabled	4	"Midi over UDP" disabled in SpotOn menu options
Error_Unknown	5	unknown error detected

Status, Data1 and Data2 are the standard Midi message bytes.

#### Status byte

The Status byte carries the channel number and the on/off state - the channel number is represented by the lower 4 bits (0..15) and the on/off state by the upper 4 bits (0x8 = off and 0x9 = on).

NB Midi Channel numbers in the message are 0..15 - SpotOn will translate this range into 1..16

So for channel 0 On the status byte would be 0x90  
and for channel 0 Off the status byte would be 0x80

Similarly for channel 2 On the status byte would be 0x92  
and for channel 2 Off the status byte would be 0x82

#### Data1 byte

The Data1 byte carries the Note number 0..127

So for note 2 the Data1 byte would be 0x02  
and for note 33 the Data1 byte would be 0x21

#### Data2 byte

Data2 byte is generally ignored by SpotOn so can be left at 0x00

As an example the Midi message for Channel 1, Note 2 On, comprises 0x91,0x02,0x00

However when sending a Note On message the Data2 byte refers to the volume/level of the note, normally this is ignored by SpotOn, but when the option 'Convert Velocity=0 to Note Off' (Options|Midi Control) is selected, a Note On message with Data2 set to 0 will be interpreted as a Note Off. When Data2 has any value other than zero, the action of the Note On message is not modified

Similarly:-

Midi message for Channel 15, Note 2 Off, comprises 0x8F,0x02,0x00

Midi message for Channel 0, All Notes Stop, comprises 0xB0,0x78,0x00

Midi message for Channel 0, All Notes Off, comprises 0xB0,0x7B,0x00

All Notes Stop will stop all tracks immediately

All Notes Off will stop all tracks using their fade out times

The All Notes Off and All Notes Stop messages directed to Channel 0 act globally on all buttons irrespective of whether they have any midi assignments

The All Notes Off and All Notes Stop messages are only recognised when the Channel value is set to 0, messages directed to channels 1..15 are ignored

## **Additional Commands**

Additional commands for listing tracks and playout control are also implemented under the CUES and LIST messages detailed below.

### LIST Command

The message format consists of 8 bytes (0..7)

Bytes 0..7 form the header

Byte 0 = 'L'

Byte 1 = 'I'

Byte 2 = 'S'

Byte 3 = 'T'

Byte 4 = 0x00 // 0x00 to list button titles, 0x10 to list track numbers playing

Byte 5 = 0x00

Byte 6 = 0x00

Byte 7 is a checksum of bytes 0..6 modulus 256

### LIST Reply

The message format consists of 8 bytes (0..7) the data length is limited to 256 bytes so several message packets may be sent. The number of packets and packet number are coded into byte 6.

When bit 7 of byte 6 is set low the bits 0..6 represent the number of packets in the message and that this is the first packet.

When bit 7 of byte 6 is set high the bits 0..6 represent the index number of this packet

Bytes 0..7 form the header

Byte 0 = 'L'

Byte 1 = 'I'

Byte 2 = 'S'

Byte 3 = 'T'

Byte 4 = 0x00 // 0x0? button titles, 0x1? track numbers playing, LSN = Error Code

Byte 5 = number of Data bytes following header including final checksum

Byte 6 = MSB=0: number of packets; MSB=1: packet index (PacketIdx=[Byte6 and 0x7f])

Byte 7 is a checksum of bytes 0..6 modulus 0x100

Byte 8..N-2 data bytes

<3 digit Button number><=><BtnTitle><crlf>

Byte N-1 = LSB of 16 bit checksum of bytes 8..N-2 modulus 0x10000

Byte N = MSB of 16 bit checksum of bytes 8..N-2 modulus 0x10000

examples:-

001=BtnTitle1**crlf**002=BtnTitle2**crlf**.....320=LastBtnTitle**crlf**

button 1 title is 'BtnTitle1'

button 2 title is 'BtnTitle2'

...

button 320 title is 'LastBtnTitle'

### CUES Command

The message format consists of 8 bytes (0..7)

Bytes 0..7 form the header

Byte 0 = 'C'

Byte 1 = 'U'

Byte 2 = 'E'

Byte 3 = 'S'

Byte 4 = 0x00

Byte 5 = LSB of number of Data bytes following header including final checksum

Byte 6 = MSB of number of Data bytes following header including final checksum

Byte 7 is a checksum of bytes 0..6 modulus 256

Byte 8..N-2

<+,-,\*,!><n,[n],[nn]><BtnTitle><;><+,-,\*,!><n,[n],[nn]><BtnTitle><;>

+ = Play

- = Stop

\$nnn = play button nnn, number range 1..320

%nnn = stop button nnn, number range 1..320

@nnn = loop button nnn, number range 1..320

\*n = Select page n, number range 1..8

! = All Stop

^ = Page Stop

[n] = delay play by n\*100mS

[nn] = delay play by nn\*100mS maximum delay is 5 seconds

Byte N-1 = LSB of 16 bit checksum of bytes 8..N-2 modulus 65536

Byte N = MSB of 16 bit checksum of bytes 8..N-2 modulus 65536

examples:-

CUES+BtnTitle1;-BtnTitle2;+[10]BtnTitle3;\*4

Play BtnTitle1

Stop BtnTitle2

Play BtnTitle3 after delay of 1 second (10\*100mS)  
Change to page 4

CUES!

Stop All tracks

To send the command to Play a button with a button text 'test' use the following byte sequence:-

0x63 0x75 0x65 0x73 0x00 0x07 0x00 0xB7 0x2B 0x74 0x65 0x73 0x74 0xEB 0x01

Which represents:-

CUES!!!!+test!! // Where ! indicates binary values

Bytes 0..7 form the header

Byte 0 = 'C'

Byte 1 = 'U'

Byte 2 = 'E'

Byte 3 = 'S'

Byte 4 = 0x00

Byte 5 = 0x07 LSB of number of Data bytes following header including final checksum

Byte 6 = 0x00 MSB of number of Data bytes following header including final checksum

Byte 7 = 0xB7 checksum of bytes 0..6 modulus 0x100

Bytes 8..17 form the message data

Byte 8 = 0x2B '+'

Byte 9 = 0x74 't'

Byte 10 = 0x65 'e'

Byte 11 = 0x73 's'

Byte 12 = 0x74 't'

Byte 13 = 0xEB LSB of checksum of bytes 8..12 modulus 0x10000

Byte 14 = 0x01 MSB of checksum of bytes 8..12 modulus 0x10000

### CUES Reply

The message format consists of 8 bytes (0..7)

Bytes 0..7 form the header

Byte 0 = 'C'

Byte 1 = 'U'

Byte 2 = 'E'

Byte 3 = 'S'

Byte 4 = nn // Error code

Byte 5 = 0x00

Byte 6 = 0x00

Byte 7 is a checksum of bytes 0..6 modulus 0x00

## The NOTE command returns a list of the Midi notes assigned to the active buttons

### NOTE Command

The message format consists of 8 bytes (0..7)

Bytes 0..7 form the header

Byte 0 = 'N'

Byte 1 = 'O'

Byte 2 = 'T'

Byte 3 = 'E'

Byte 4 = 0x00

Byte 5 = 0x00

Byte 6 = 0x00

Byte 7 is a checksum of bytes 0..6 modulus 256

### NOTE Reply

The message format consists of 8 bytes (0..7) the data length is limited to 256 bytes so several message packets may be sent. The number of packets and packet number are coded into byte 6.

When bit 7 of byte 6 is set low the bits 0..6 represent the number of packets in the message and that this is the first packet.

When bit 7 of byte 6 is set high the bits 0..6 represent the index number of this packet

Bytes 0..7 form the header

Byte 0 = 'N'

Byte 1 = 'O'

Byte 2 = 'T'

Byte 3 = 'E'

Byte 4 = 0x00

Byte 5 = number of Data bytes following header including final checksum

Byte 6 = MSB=0: number of packets; MSB=1: packet index (PacketIdx=[Byte6 and 0x7f])

Byte 7 is a checksum of bytes 0..6 modulus 0x100

Byte 8..N-2 data bytes

<3 digit Button number><=><BtnMidiNote><crlf>

Byte N-1 = LSB of 16 bit checksum of bytes 8..N-2 modulus 0x10000

Byte N = MSB of 16 bit checksum of bytes 8..N-2 modulus 0x10000

examples:-

```
001=02/064/1crlf002=**/123/0crlf005=?/?/?/?crlf....320=LastBtnMidiNotecrlf
```

button 1 Midi note is '02/064/1' - Channel 3, Note 64, On

button 2 Midi note is '\*\*/123/0' - any channel, Note 123, Off

button 5 Midi note is '?/?/?/?' - no Midi note assigned

...

button 320 title is 'LastBtnTitle'

NB Midi Channel numbers in message are 0..15 - SpotOn will translate this into 1..16

## Error Codes

Reply code can take the following values:-

Error_None	0	message received correctly
Error_UnRecognisedHeader	1	header bytes not recognised
Error_BadHeaderChecksum	2	checksum byte in header does not match calculated checksum
Error_BadData	3	Message data invalid format
Error_NotEnabled	4	"Midi over UDP/TCP" disabled in SpotOn menu options
Error_Unknown	5	unknown error detected
Error_BadData Checksum	6	checksum word in data does not match calculated checksum
Error_BadMsgByteCount	7	number of bytes given in message is invalid

## **Midi Channel Numbering**

The Midi Channel numbering started off as a bit of a mess and has now stabilised into a slightly smaller mess.

Originally there was a user option to switch between 0 and 1 based Midi Channel numbering as viewed by the operator, the underlying code always worked on 0 based as that agreed with the raw Midi data values being handled. The default setting for the users was 0 based.

Then Midi over UDP then came along and was coded as 0 based, after some/many comments and a survey on IBSNet the conclusion was to hard code SpotOn to be 1 based so the users always see the Midi channels numbered 1..16.

Unfortunately changing the Midi over UDP to also be 1 based would break existing third party code so the decision was made to leave the UDP/TCP commands as 0 based.

## **OSC Commands**

```
audio/button(BtnNum, Action) // BtnNum = 1..320, Action = stop/play
audio/allstop                // stop all tracks
audio/buttontitle(BtnNum)    // BtnNum 1..320, returns button title text
audio/buttonfile(BtnNum)     // BtnNum 1..320, returns WAV filename
```

SpotOn listens on UDP port 4700 in SpotOn version 0v993 08/06/21 or later.

BtnNum is an integer, play and stop actions are text strings.

[‘OSC over UDP’](#) will need to be enabled via the Engineering menu as well as [‘Midi In over UDP’](#) or [‘Midi In over TCP’](#) selected and also [‘Midi In On’](#) should be set in the status bar.

Examples from the 'TouchOSC' utility:-

Play button 194

The screenshot shows the configuration for an OSC message. The message name is "/audio/button 194 play". It is enabled and set to send. The trigger is a touch event on connection 1. The address is "/ name / button" and the arguments are "194" and "play".

Messages (1) +						
OSC /audio/button 194 play x						
Enabled	✓					
Send	✓					
Receive						
Feedback						
Connections	∞	1	2	3	4	5
Trigger	x					▼
	touch					FALL ▼
Address	/	name	/	button	+	
Arguments	194	play	+			

Stop button 194

The screenshot shows the configuration for an OSC message. The message name is "/audio/button 194 stop". It is enabled and set to send and receive. The trigger is a touch event on connection 1. The address is "/ name / button" and the arguments are "194" and "stop".

Messages (1) +						
OSC /audio/button 194 stop x						
Enabled	✓					
Send	✓					
Receive	✓					
Feedback						
Connections	∞	1	2	3	4	5
Trigger	x					FALL ▼
	touch					▼
Address	/	name	/	button	+	
Arguments	194	stop	+			

Stop all tracks

The screenshot shows the configuration for an OSC message. The message name is "/audio/allstop". It is enabled and set to send and receive. The trigger is a touch event on connection 1. The address is "/ name / allstop" and there are no arguments.

Messages (1) +						
OSC /audio/allstop x						
Enabled	✓					
Send	✓					
Receive	✓					
Feedback						
Connections	∞	1	2	3	4	5
Trigger	x					FALL ▼
	touch					▼
Address	/	name	/	allstop	+	
Arguments	+					

## Plain Text Commands

SpotOn listens on TCP port 4650 and UDP port 4750 for plain text control messages when the Engineering/Plain Text over TCP|UDP option is enabled.

The appropriate Engineering/MidiIn over Network TCP|UDP options should also be enabled along with "MidiIn On" on status bar.

These messages are of the form:-

SpotOn_play_1	play track on button 1
SpotOn_play_320	play track on button 320
SpotOn_stop_1	stop track on button 1
SpotOn_stop_320	stop track on button 320
SpotOn_allstop	stop all tracks
SpotOn_stoppage_X	stop all tracks on page X (1..8)
SpotOn_steptonext_home	set StepToNext cursor to top left
SpotOn_steptonext_end	set StepToNext cursor to bottom right
SpotOn_steptonext_play	play highlighted StepToNext button
Play 001	play track on button 1*
Stop 012	stop track on button 12*
Stop all	stop all tracks
Stoppage_X	stop all tracks on page X (1..8)
Steptonext_home	set StepToNext cursor to top left
Steptonext_end	set StepToNext cursor to bottom right
Steptonext_play	play highlighted StepToNext button

\*Add leading zeros to make a 3 digit Button number

Midi 3 7 on	send emulated Midi message Channel 3/Note 7/On
Midi 5 18 off	send emulated Midi message Channel 5/Note 18/Off

The text and numbers in the messages are separated by the underscore "\_" or white space character, the text is not case sensitive.

# EmBER+ Control

SpotOn can be controlled via the "EmBER+" open protocol based on initiatives out of the Lawo Group and L-S-B Broadcast Technologies GmbH.

A utility called "SpotOn\_MB" can interface between an external third-party EmBER+ controller and SpotOn.

When "SpotOn\_MB" is running it is hidden in the Windows taskbar system tray, the icon can be seen top left of the icon list (there maybe similar looking icons present that represent other SpotOn interface utilities).

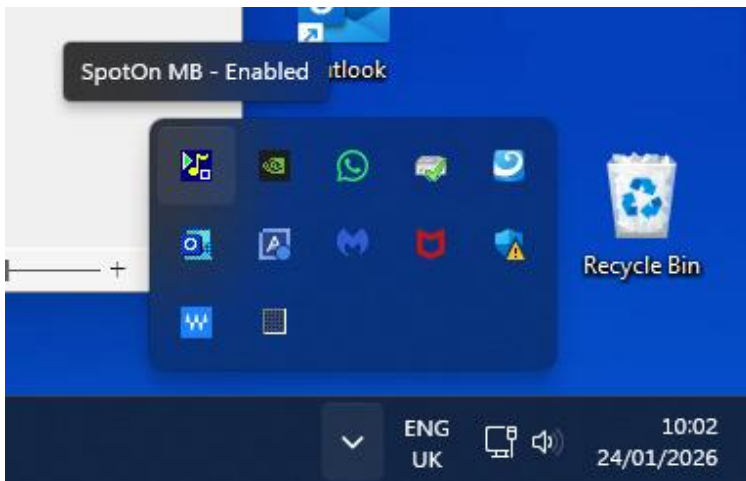

Right-clicking on the SpotOn\_MB icon displays a popup menu.

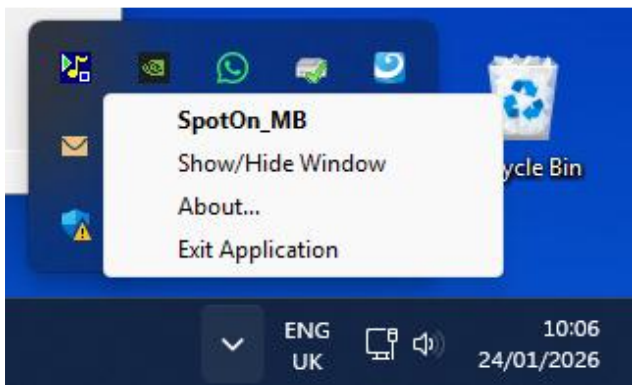

Use Show/Hide option to make the SpotOn\_MB window visible.

In the SpotOn\_MB main window, the lower left status panel will show 'Searching...' until SpotOn is located.

Lower right status panel shows communication to SpotOn is currently enabled – clicking this panel will toggle the communication on/off.

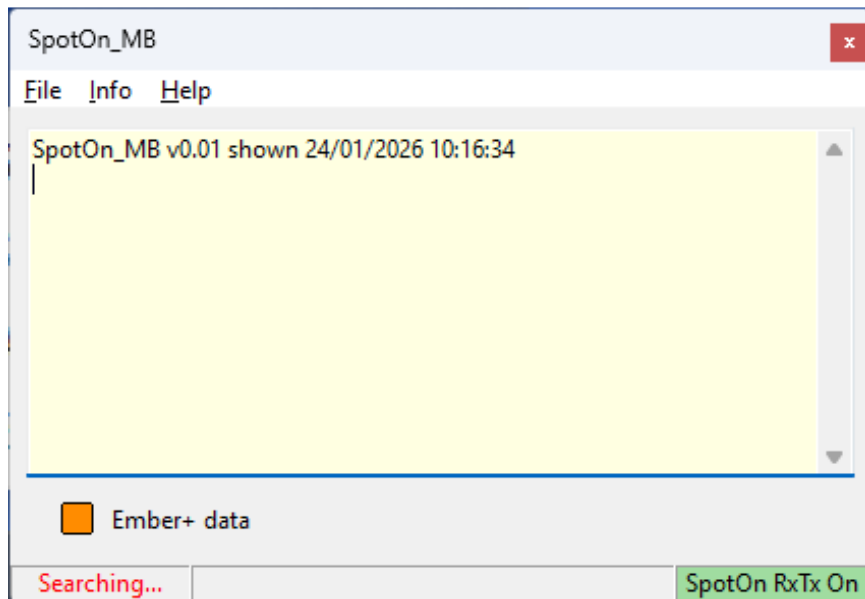

Status panel will change to show 'SpotOn' found when communication has been established.

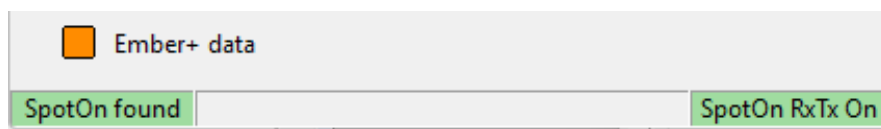

The EmBER+ indicator will flash green when incoming from an EmBER+ controller is received.

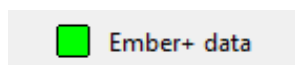

The main menu Info/Event Logs will show the most recent events.

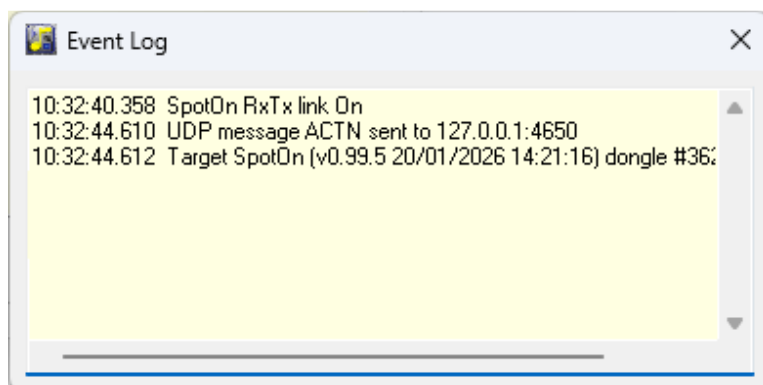

The normal mode of operation is with "SpotOn\_MB" hidden and connection to SpotOn is automatic with no user action required.

The next page shows how SpotOn might appear to an external third-party EmBER+ controller.

**Communication Ports** [Add...](#)

- localhost:9000
  - 001 Device
    - 001 Identity
      - 001 Copyright ————— David Markie 2026
      - 002 Product ————— SpotOn\_MB
      - 003 Version ————— 0.01
    - 002 Host
      - 001 HostName ————— SpotOn
      - 002 HostVersion ————— v0.99.6
      - 003 HostBuildDate ————— 24/01/2026 09:15:10
    - 003 GPI
    - 004 GPO
    - 005 Buttons
      - 001 Layout
        - 001 NumberOfPages ————— 8
        - 002 ButtonsPerPage ————— 35
        - 003 **CurrentPage** ————— 7
        - fx* 004 Stop buttons on current page
        - fx* 005 Stop all buttons
      - 002 StepToNext
        - fx* 001 StepToNext Home
        - fx* 002 StepToNext End
        - fx* 003 Step to Next
      - 003 ButtonBanks
        - 001 Bank\_0xx
          - 001 Btn\_1
            - 001 Active ————— True
            - 002 Name ————— Open - NEW
            - 003 **Playing** ————— True
          - 002 Btn\_2
            - 001 Active ————— True
            - 002 Name ————— Walk - NEW
            - 003 **Playing** ————— False
          - 003 Btn\_3
          - 004 Btn\_4
          - 005 Btn\_5
          - 006 Btn\_6
          - 007 Btn\_7
          - 008 Btn\_8
          - 009 Btn\_9
          - 010 Btn\_10
          - 011 Btn\_11

**Contents**

Tag	Field	Type	Value
C-0	identifier	UTF8	Playing
C-5	access	Integer	3
C-2	value	Boolean	True

localhost:9000/Device/Buttons/ButtonBanks/Bank\_0xx/Btn\_1/Playing Value:

Time	Message
1/24/2026 9:15:32 AM	1 EndPoints created
1/24/2026 9:15:32 AM	EmberPlusView v1.6.2.0 started

# PBus Control

SpotOn can be controlled via the industry standard PBus commands, the PBus interface is most commonly found on vision switchers/mixers where it allows generic remote control commands to be incorporated into the timeline of the memory system. SpotOn currently responds to two PBus commands Recall and Trigger.

The PBus interface is strictly RS485 which is configured as one master (switcher) and many slaves (devices), normally the master transmits messages and the slaves perform some task, the slaves represented by SpotOn do not send a reply on the PBus interface.

To use an RS485 interface on a standard PC either a RS232/485 or a RS232/422 converter will be required.

PBus Control can be enabled via the Options menu or by shift right-clicking on the GPI In panel in the status bar. The GPI In panel text is shown underlined when PBus control is enabled



the text colour will flash cyan when a PBus trigger is received (text flashes red when GPI triggers are received)



The PBus setup screen is shown below.

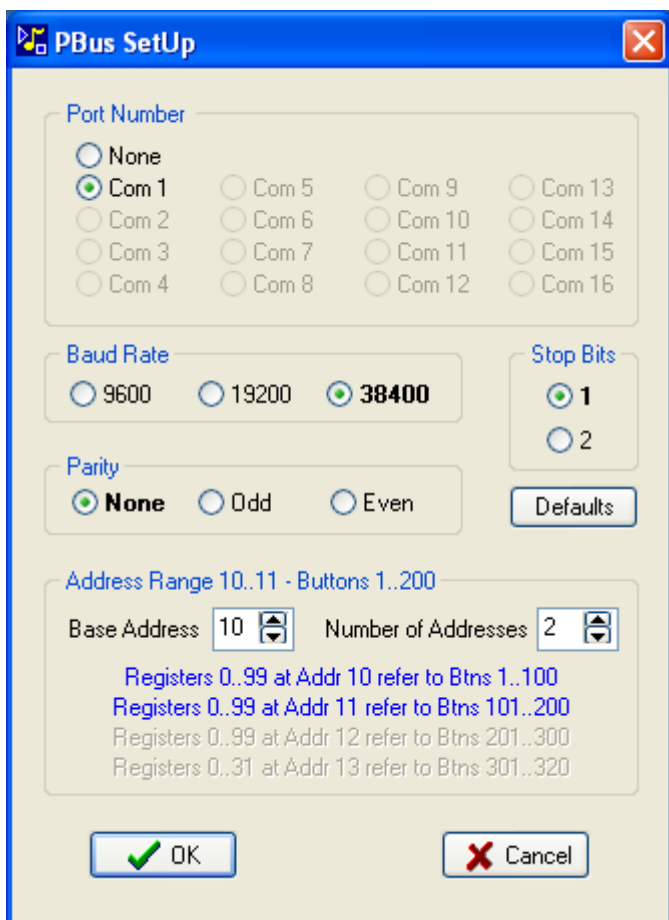

The screen is split into three sections ports, format and addresses.

## Ports

Port Number

<input type="radio"/> None	<input type="radio"/> Com 5	<input type="radio"/> Com 9	<input type="radio"/> Com 13
<input checked="" type="radio"/> Com 1	<input type="radio"/> Com 6	<input type="radio"/> Com 10	<input type="radio"/> Com 14
<input checked="" type="radio"/> Com 2	<input type="radio"/> Com 7	<input type="radio"/> Com 11	<input type="radio"/> Com 15
<input type="radio"/> Com 3	<input type="radio"/> Com 8	<input type="radio"/> Com 12	<input type="radio"/> Com 16
<input type="radio"/> Com 4			

Here the PC com port to be used as the PBus input is assigned, only ports 1..4 can be selected and those ports that are not fitted or otherwise unavailable are greyed out. In the example ports 1+2 are available, ports 3+4 are not available - not fitted in this case - and ports 5..16 not available for selection

## Format

Baud Rate

9600    19200    **38400**

Stop Bits

**1**    2

Parity

**None**    Odd    Even

Defaults

The format of the data sent on the PBus is defined by the master - usually the vision switcher - so the SpotOn settings for baud rate, parity and number of stop bits can all be changed to match. The default values are highlighted in bold text and these values can be set by clicking the Defaults button

## Addresses

Address Range 10..11 - Buttons 1..200

Base Address    Number of Addresses

Registers 0..99 at Addr 10 refer to Btns 1..100  
Registers 0..99 at Addr 11 refer to Btns 101..200  
Registers 0..99 at Addr 12 refer to Btns 201..300  
Registers 0..31 at Addr 13 refer to Btns 301..320

As there is one master and one or more slaves connected to the PBus, there has to be a method of identifying each separate slave. This is achieved by using 'addresses' 0..23, each slave can respond to commands sent to one or more addresses.

In the Address section SpotOn can be set to use a range of contiguous addresses formed by a base address and then the number of addresses. In the example above the base address is 10 and the number of addresses is 2 giving the address range 10 and 11.

If you increase the number of addresses to 3 then SpotOn acts as devices 10, 11 & 12 with device 10 representing buttons 1..100, device 11 buttons 101..200 and device 12 buttons 201..300.

The commands to play say button 120 would be:-

Recall Device 11 register 20 // arms button 120 ready to play (button 20 in device 11 range of 101..200)

Trigger Device 11 function 1 // to play button ..

Trigger Device 11 function 0 // to stop button

The commands to play say button 54 would be:-

Recall Device 10 register 54 // arms button 54 ready to play (button 54 in device 10 range of 1..100)

Trigger Device 10 function 1 // to play button ..

Trigger Device 10 function 0 // to stop button

## **Message Format**

The PBus protocol is ASCII based and the two commands recognised by SpotOn are Recall and Trigger:-

Recall - Rddddddrr<cr>

The first byte is the ASCII keyword for Recall (R)

Next is a 6 byte field of ASCII characters (dddddd) this is a bit map identifying which range of buttons are included in the Recall

Followed by a 3 byte field of ASCII characters (rrr) giving the register number (SpotOn button) to be recalled

Trigger - Tddddddg<cr>

The first byte is the ASCII keyword for Trigger (T)

Next is a 6 byte field of ASCII characters (dddddd) this is a bit map identifying which range of buttons are included in the Trigger

Followed by a single ASCII character (g) giving the function to be performed (0 = SpotOn Stop, 1 = SpotOn Play)

# Locked Attributes

Locked attributes refers to the 'Lock Note', 'Lock HotKey' and 'Lock Colour' to button checkboxes

Lock Note In/Play to Btn     Lock Note In/Stop to Btn     Lock Note Out to Button

Lock HotKey to button    Lock colour to button

When checked, these will 'Lock' the attribute to the button number, meaning that if the button is reloaded with another track then the attribute will remain unaffected.

This allows a fixed set of attributes (Colours, HotKeys and Midi notes) to remain assigned whilst buttons are reloaded, the following description applies to both HotKeys and Midi notes.

Below is a section of the main screen showing buttons 1, 2, 11, and 12, at this stage no hotkeys have been assigned to any of these buttons.

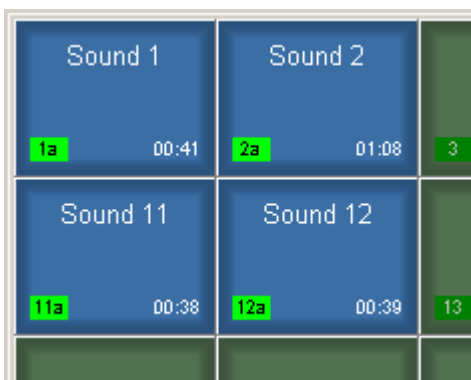

Now the HotKeys A, B, C and D are assigned and the HotKey on button A is 'Locked to button'

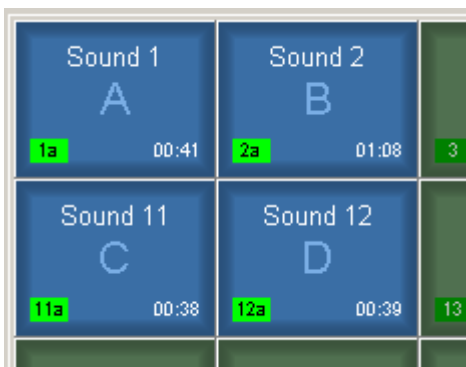

Cut and pasting button 2 onto button 11 results in button 11 contents being entirely replaced by those from button 2.

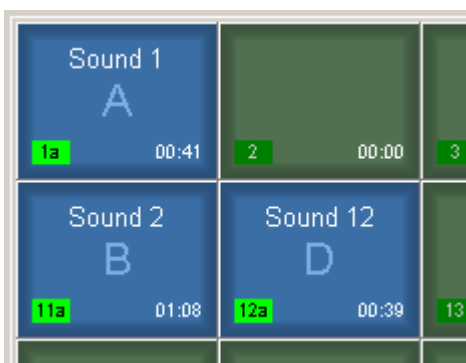

Now cut and pasting button 12 onto button 1 gives:-

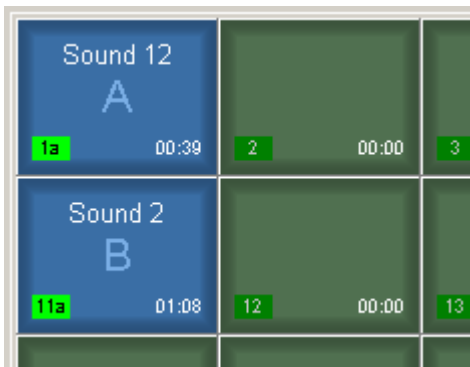

Here button 1 has retained the HotKey 'A' that it had before, due to it being Locked to the button.

Now if button 1 is moved to button 2, button 2 takes its original hotkey assignment

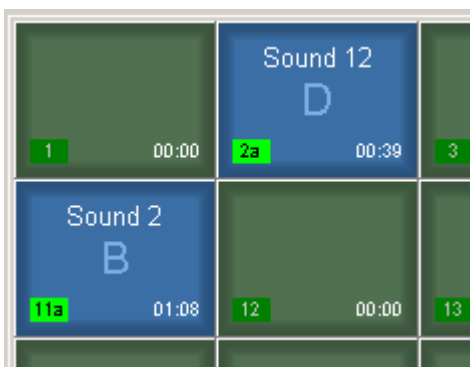

If a completely new track is loaded onto button1 it will take the Locked hotkey assignment

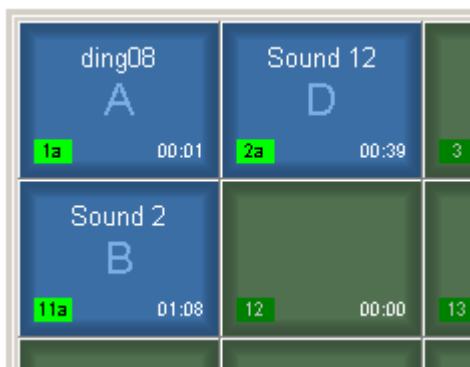

The only method of removing the Locked hotkey is to either uncheck the 'Lock HotKey to button' checkbox for button 1, or to 'Clear' the button from the popup menu

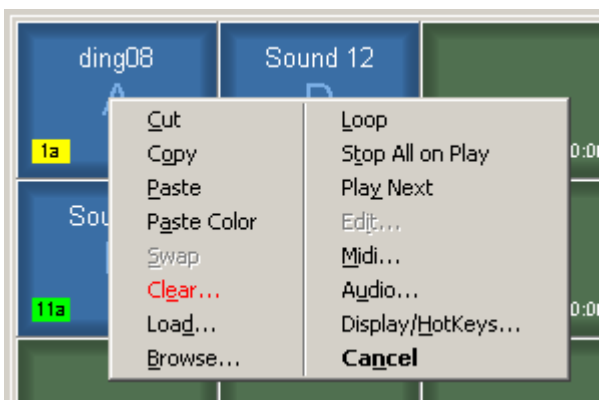

# Button Icons



Unassigned button with no track loaded and default color scheme

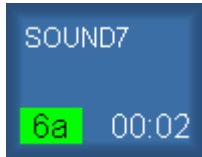

Assigned button with no modifiers, audio output is routed to o/pA. Track name is SOUND 7 and length 2s

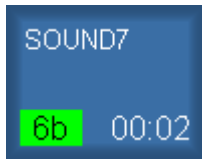

Assigned button with no modifiers, audio output is routed to o/p B

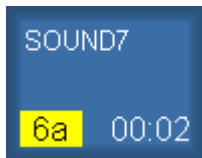

Button parameters are being edited

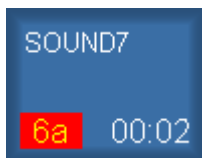

Button is playing

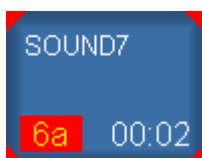

Button is playing with Highlight Play option

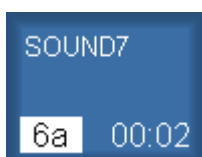

Button is selected in "Step To Next" mode and will play on press of Spacebar

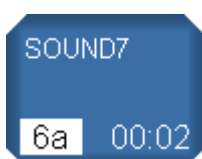

Button is selected in "Step To Next" mode and will play on press of Spacebar - Highlight Step to Next Selected

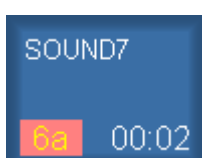

Button is selected in "Step To Next" mode and is playing

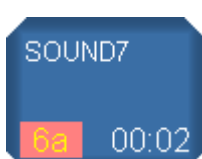

Button is selected in "Step To Next" mode and is playing - Highlight Step to Next Selected

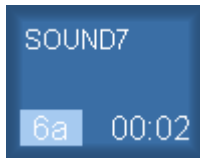

Fading In

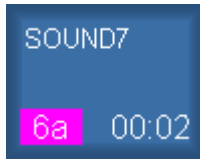

Fading out



Track is within 3 seconds of end



Track Duration label showing Elapsed Time instead of the default Time Remaining

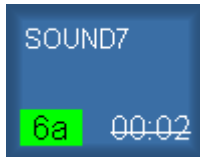

Track audio is muted

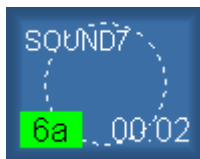

The track will loop continuously over its full length or between its In and Out points if specified



The track will loop continuously over its full length or between its In and Out points if specified until stopped when then loop mode will be cancelled

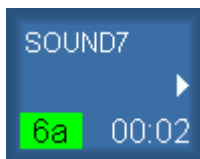

When this track reaches the end or the start of its fade out time the next numbered track will be played

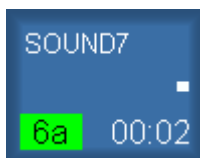

When this track is played all other tracks will be stopped using their fade out times



When this track is played all other tracks on the current page will be stopped using their fade out times

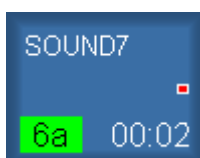

Stop track when left mouse button is released

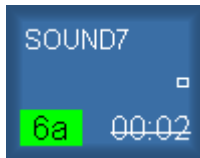

When this track is played all other tracks will be stopped without using their fade out times

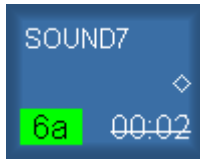

When this track is played all other tracks on the current page will be stopped without using their fade out times

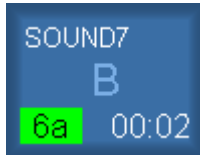

This track will play when QWERTY key B is pressed



This track will play when function key F3 is pressed

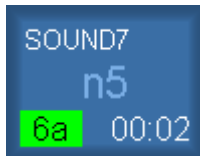

This track will play when numeric keypad 5 is pressed with NumLock active and is in Ganged mode



This track will play when numeric keypad 5 is pressed with NumLock active and is in Overlapped mode

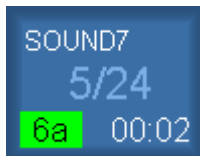

This track will play when Midi In Channel/Note received is 5/24 and is in Ganged mode



This track will play when Midi In Channel/Note received is 5/24 and is in Overlapped mode

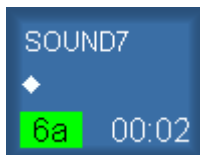

A GPI becoming active will play this track

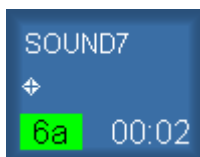

A GPI becoming active will play this track and more than one GPI is assigned to this track

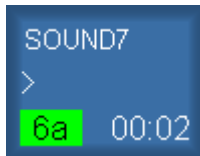

A specified Midi message will play or stop the track

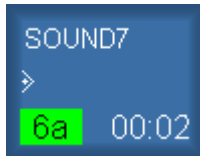

Track has Midi In messages for both Play and Stop assigned

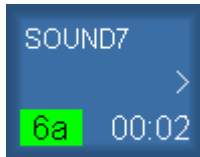

A specified Midi message will be sent when this track starts to play

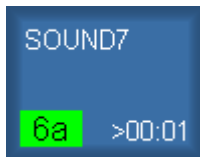

In point of track has been trimmed

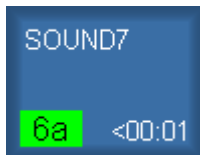

Out point of track has been trimmed

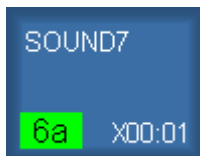

Both the In and Out points have been trimmed

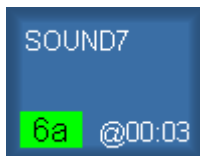

Speed has been adjusted

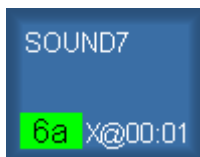

Both the In and Out points have been trimmed along with a change in speed setting

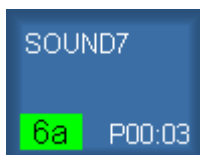

Track is a PlayList of total duration 3 seconds

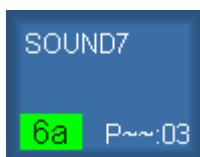

Track is a PlayList with total duration greater than 1 hour

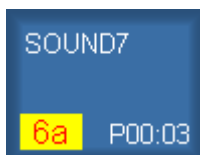

PlayList has just received an exit repeat loop message, see [Advanced Operation](#)

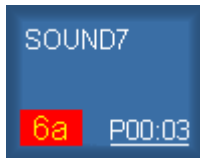

PlayList has previously received an exit repeat loop message see [Advanced Operation](#)

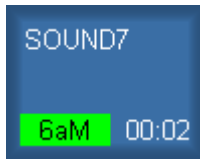

Button is a Link Master



Button is a Link Slave

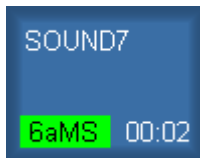

Button is both a Link Master and a Link Slave



Button is a member of Group 3



Button has a Play Delay setting active



Button is currently waiting until Play Delay expires and will then Play



Button is currently waiting until Play Delay expires and will then Play

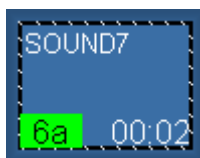

Button paused

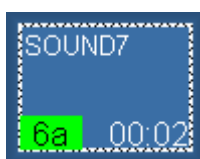

Button being played in Preview mode via assigned preview output

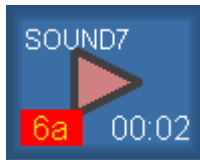

Button played externally by GPI,  
Midi...

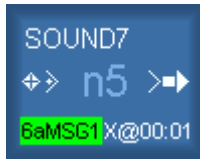

Most combinations of options

# Command Line Switches

SpotOn can be started with a number of command line switches:-

/adminpassword	opens up Engineering and Admin menus on startup
/AdvancedEdit	starts SpotOn in Advanced Editing mode
/AltAppDataDir	redirects saving of all local system files to new folder eg /AltAppDataDir="c:\temp"
/Multi2	forces multichannel enabled version to run in 2 channel stereo mode
/Multi4	enables handling of 4 channel audio tracks (surround)
/Multi6	enables handling of 6 channel audio tracks (5.1)
/Multi8	enables handling of 8 channel audio tracks (7.1)
/multipassword	password to enable multi-channel payout
/NoMenus	disables user menus at startup
<a href="#">/Prep</a>	starts SpotOn with 16 audio output devices even if fewer are fitted
/KeyMonitor	displays dongle presence bargraph
/NoBtnText	removes all text from buttons
<a href="#">/HardwareMxr</a>	opens output devices using hardware mixers if available
/ChaseTCode	enables the chasing to timecode for auto play buttons
/PlayBtns	auto play buttons in a comma separated list eg /PlayBtns172,173,200

To use these command line switches right click the shortcut to SpotOn on the Desktop and select properties, on the popup window choose the Shortcut tab and then examine the Target entry, which should be something like:-

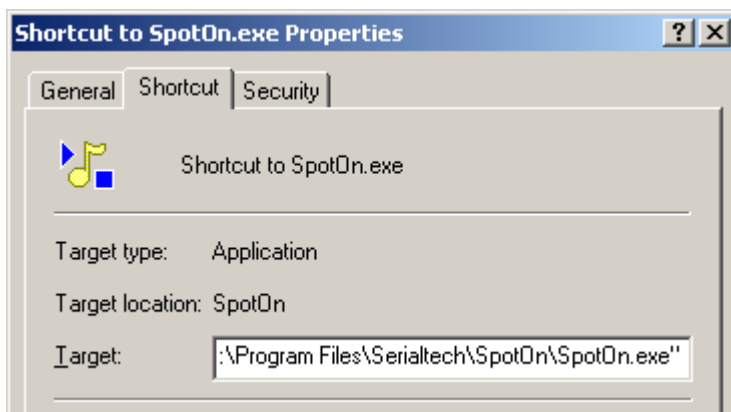

Command line switches can be added at the end on the entry after the closing double quote mark, for instance to use Advanced Editing:-

"C:\Program Files\Serialtech\SpotOn\SpotOn.exe" /AdvancedEdit

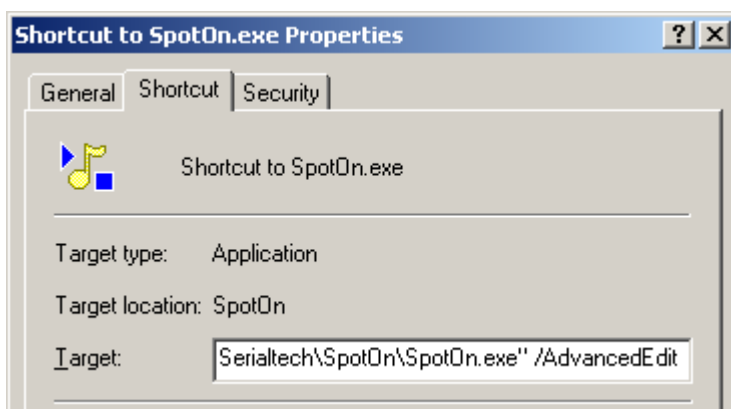

multiple switches can be included

"C:\Program Files\Serialtech\SpotOn\SpotOn.exe" /AdvancedEdit /Multi6



### Preparation Mode

Preparation (Prep) mode is entered by using the /Prep command line switch, this will force SpotOn to provide 16 output devices even though only 1 or 2 may actually be present on the computer. This allow for packages to be prepared on a computer that does not have the same number of audio outputs as the eventual destination computer, eg laptop prep PC vs fully configured show PC.

When in prep mode the status bar will be coloured yellow

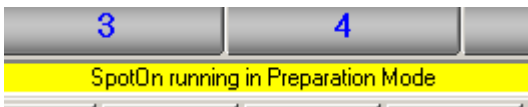

In the Audio window a long list of outputs will appear, the existing audio outputs are supplemented by additional references to the Windows preferred output device - in this case the Creative SB Extigy

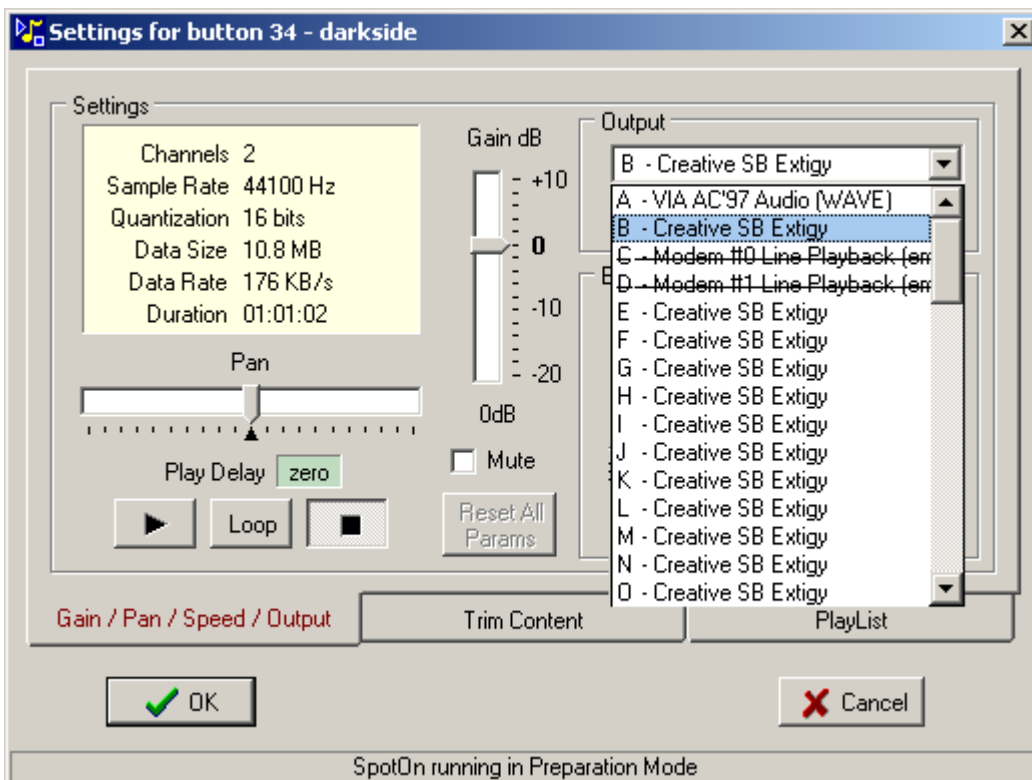

# Settings

## Parameters saved in Session or Package file (per session):-

### Display

- Main Window position and size
- Main Window tab height S/M/L
- Main Window status bar height S/M/L
- Button shaded edge width %
- Button separator grid lines on/off
- Edged button text on/off
- Flash button number when playing
- Highlight buttons playing
- PopUp hints on/off
- Search menu button enabled on/off
- Menu icons on/off
- Flash tab when tracks are playing on/off
- Start number each page from 1 on/off
- Focus SpotOn when Scroll Lock key pressed
- Use output colour + colour table
- Use genre colours + colour table
- Double press of ScrollLock to bring SpotOn into focus
- Button right click Group Output popup
- Trim window level bar style
- Use soft waveform cursor in trim window
- Show external button trigger
- Button trigger size S/M/L
- Allow per button fonts
- Show tracks already played as black buttons
- Location of Position bars
- Level meter display mode PPM/dB

### Midi

- Use Midi on on/off
- Use Midi out on/off
- Midi in devices selected
- Midi out device selected
- Use internal Midi loop back on/off
- Send All Notes Off when All Stop triggered on/off
- Convert velocity of zero to Note Off message on/off
- Treat buttons with duplicate Midi In notes as overlapped on/off
- Restrict Midi In notes to act on current page only on/off
- Show Midi in text on button on/off
- Show Midi in/out symbol on button on/off

### HotKeys

- HotKeys enabled on/off
- Treat buttons with duplicate HotKeys as overlapped on/off
- Restrict HotKeys to act on current page only on/off
- Show HotKeys text on buttons on/off

### Step to Next

Enable Step to Next mode on/off  
Skip Muted buttons on/off  
Skip buttons in PlayNext sequence on /off

### Mouse Options

Left/Right = Start/Stop on/off  
Mouse centre click to pause on/off  
Mouse centre click to step to next PlayList item on/off  
Mouse Centre+Right- click to display button menu on/off  
Play click debounce time 0..XXmS

### Audio

Gain Offset -10dB on/off  
Use Play Delay mode on/off  
Fade out time default 0..XXmS  
Use sound card hardware mixers on/off  
Fade in/out limit 0..XXdB  
Auto Preview tracks in Load window  
Lock Session Files  
User Audio editor application  
AutoCopy button wav filename to Windows clipboard  
Use Micro FadeIn  
Use Micro FadeOut

### Master/Slave Links

Use Master/Slave links on/off  
Buzzer group hold off time 0..XXs  
Link names

### GPIs

Use GPI in triggers on/off  
Show GPI in symbol on button on/off  
Stop button on GPI off signal on/off  
AutoArm GPI  
GPIx Button number enabled  
GPIx Emulated by Time, Midi note or Hotkey  
GPIx action = Play, Stop, Pause, UnPause, Pause/UnPause  
GPIx action = Step to Next, Home Step to Next

### Network

**Use Network Midi Out**  
**Network Midi Out Address**  
Set as Network Master/Slave  
AutoArm GPIs  
GPIx Button number enabled  
GPIx Emulated by Time, Midi note or Hotkey  
GPIx action = Play, Stop, Pause, UnPause, Pause/UnPause

GPIx action = Step to Next, Home Step to Next

#### Timecode

Source button  
Chase Offset  
Chase resync threshold

#### Misc

AutoLockTracks  
**Show NetworkMidiOutAddr**  
NetworkMasterSlave  
AutoArm GPI  
GPIx Button number enabled  
GPIx Emulated by Time, Midi note or Hotkey  
GPIx action = Play, Stop, Pause, UnPause, Pause/UnPause  
GPIx action = Step to Next, Home Step to Next

### **Parameters saved in 'Ini' file (per installation):-**

#### Folders for

Temporary files  
Local copies of WAV files  
Playout logs  
Button Colour template  
Session backups  
WAV files extracted from packages  
Default location of session files  
Last location of package file  
Default location of audio files  
Default location of image files  
Audio editor application  
Default Audio file search utility  
CD Burner utility

#### Options

Use default WAV file folder  
Start maximised  
Start with blank session  
Use timed session backups  
Try remote files if local copy is missing  
Use Splash screen  
Use soft Splash screen  
Use Win XP themes  
Lock the flashing of buttons that are playing to the same phase  
Base Midi channels on zero  
Use WAV file preview in Load dialog  
Restrict screen layout to a maximum of 10 x 8

Set keyboard NumLock to be on at startup  
Force continuous polling of GPI devices  
Recue all tracks when stopped  
Display user friendly names for audio output devices  
Automatically show session notes  
Show Page Stop button  
Show All Stop button  
Generate XML playout logs  
Delay archiving playout logs until all tracks are stopped  
Include Outputs in Group popup  
Enable Web hyperlinks  
Enable Web version check  
Filter Midi messages  
Fast Midi Mute mode  
Use Midi Velocity to preset track gain  
Maximum WAV file sample that can be loaded  
Speedbar minimum setting  
GPI input device selected  
Masking of audio output devices  
Order of audio output devices  
Ignore track names embedded in audio files  
Check volume settings on startup  
User friendly names for audio output devices  
PBus parameters  
External SMPTE timecode input configuration  
External DTMF input configuration  
Global timecode rate  
Timecode generator phase correction  
Detection threshold for AutoTrim of tracks  
Track preview output assignment  
AutoTrim audio margin  
AutoTrim detection threshold  
Playout log file column selection  
Genre names  
Genre name metadata field  
Cascade master/slave links  
Level Meter mode and position

# XML Playout Logs

Playout logs are usually saved as human readable plain text files, the entries are tab delimited so that they can be read into a spreadsheet application for further processing.

If the playout log is required to be machine readable then checking the menu option XML Playout Logs in the [Engineering menu](#) will generate XML versions of the Playout Logs each time the logs are saved.

The format of the log is set out below: -

```
<?xml version="1.0" encoding="utf-8" standalone="yes"?>
<SpotOn_XML_Reports>
  <Playout_Logs Num_of_Logs="1">
    <Playout_SubLog SubLog_Num="1">
      <Items Num_of_Items="2">
        <Item Item_Number="1">
          <PC_Clock_Time Value="20:10:14" Hours="20" Minutes="10"
Seconds="14"/>
          <Button Number="1"/>
          <Output Device="a"/>
          <Trackname Text="SOUND1"/>
          <Filename Text="SOUND1.WAV"/>
          <Copyright Text="Copyright © Cinematronics 1995"/>
          <Comments Text="none"/>
        </Item>
        <Item Item_Number="2">
          <PC_Clock_Time Value="20:10:15" Hours="20" Minutes="10" Seconds="15"/>
          <Button Number="2"/>
          <Output Device="a"/>
          <Trackname Text="SOUND20"/>
          <Filename Text="SOUND20.WAV"/>
          <Copyright Text="Copyright © Cinematronics 1995"/>
          <Comments Text="none"/>
        </Item>
      </Items>
    </Playout_SubLog>
  </Playout_Logs>
</SpotOn_XML_Reports>
```

The log file is automatically saved to a daily file PlayLog\_ddmmyy.xml in the same folder as the plain text file PlayLog\_ddmmyy.txt.

The daily log has entries appended whilst SpotOn is running, if SpotOn is shutdown and restarted during the day then a new 'SubLog' entry will be added to the XML file

```
<?xml version="1.0" encoding="utf-8" standalone="yes"?>
<SpotOn_XML_Reports>
  <Playout_Logs Num_of_Logs="2">
    <Playout_SubLog SubLog_Num="1">
      <Items Num_of_Items="2">
        <Item Item_Number="1">
          <PC_Clock_Time Value="20:10:14" Hours="20" Minutes="10"
Seconds="14"/>
          <Button Number="1"/>
```

```
<Output Device="a"/>
<Trackname Text="SOUND1"/>
<Filename Text="SOUND1.WAV"/>
<Copyright Text="Copyright © Cinematronics 1995"/>
<Comments Text="none"/>
</Item>
<Item Item_Number="2">
  <PC_Clock_Time Value="20:10:15" Hours="20" Minutes="10" Seconds="15"/>
  <Button Number="2"/>
  <Output Device="a"/>
  <Trackname Text="SOUND20"/>
  <Filename Text="SOUND20.WAV"/>
  <Copyright Text="Copyright © Cinematronics 1995"/>
  <Comments Text="none"/>
</Item>
</Items>
</Playout_SubLog>
<Playout_SubLog SubLog_Num="2">
  <Items Num_of_Items="2">
    <Item Item_Number="1">
      <PC_Clock_Time Value="10:17:34" Hours="10" Minutes="17"
Seconds="34"/>
      <Button Number="14"/>
      <Output Device="a"/>
      <Trackname Text="SOUND1xr"/>
      <Filename Text="SOUND1xr.WAV"/>
      <Copyright Text="Copyright © Cinematronics 1995"/>
      <Comments Text="none"/>
    </Item>
    <Item Item_Number="2">
      <PC_Clock_Time Value="10:19:55" Hours="10" Minutes="19" Seconds="55"/>
      <Button Number="102"/>
      <Output Device="a"/>
      <Trackname Text="SOUND203"/>
      <Filename Text="SOUND203.WAV"/>
      <Copyright Text="Copyright © Cinematronics 1995"/>
      <Comments Text="none"/>
    </Item>
  </Items>
</Playout_SubLog>
</Playout_Logs>
</SpotOn_XML_Reports>
```

# Screen Saver

As of version v0.80 SpotOn will be installed with its own screen saver as below: -

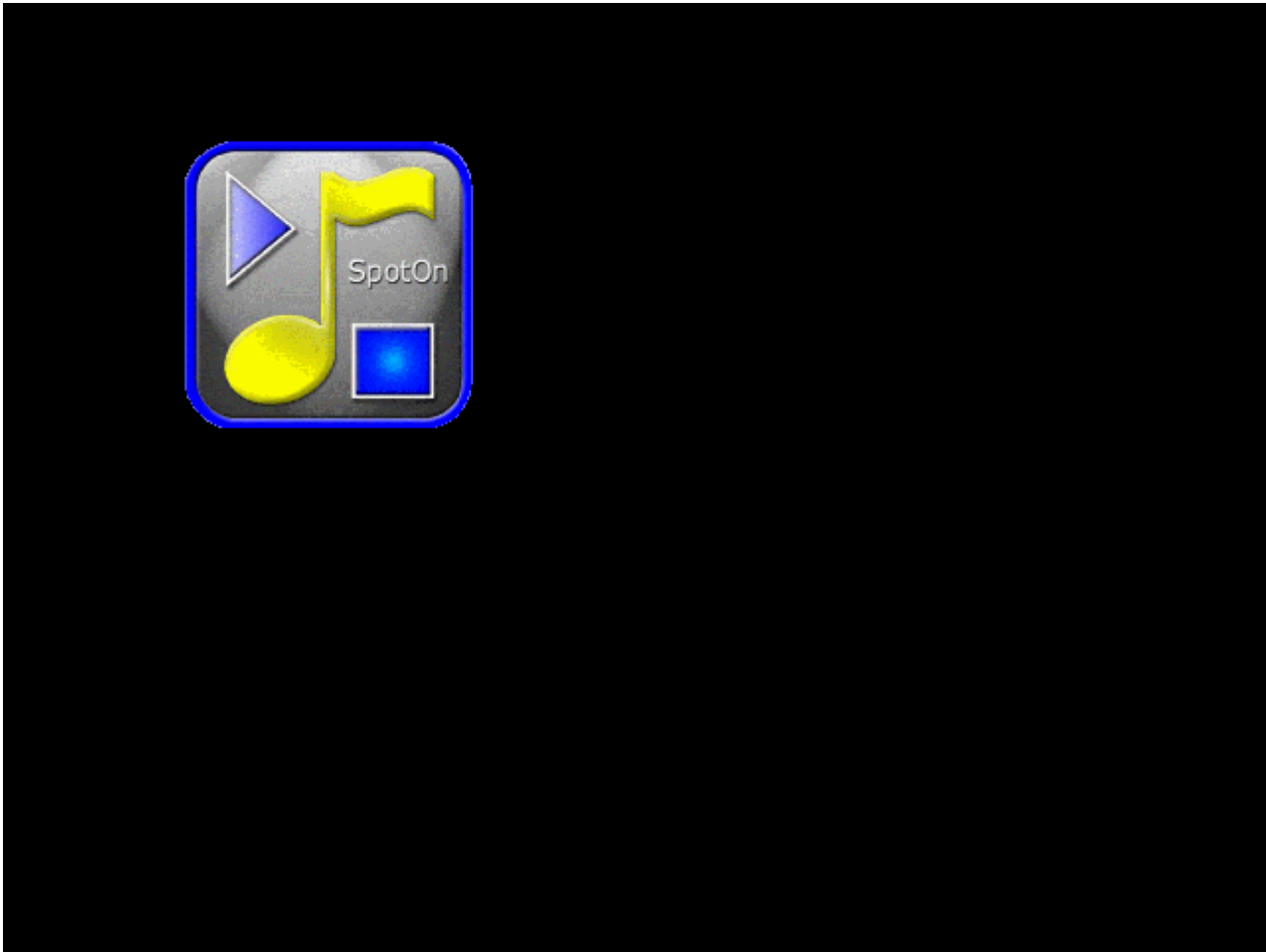

To set up the screen saver right-click on the desktop and select the properties option from the popup menu



In the properties dialog choose the Screen Saver tab and scroll down the list of installed screen savers to locate SpotOn

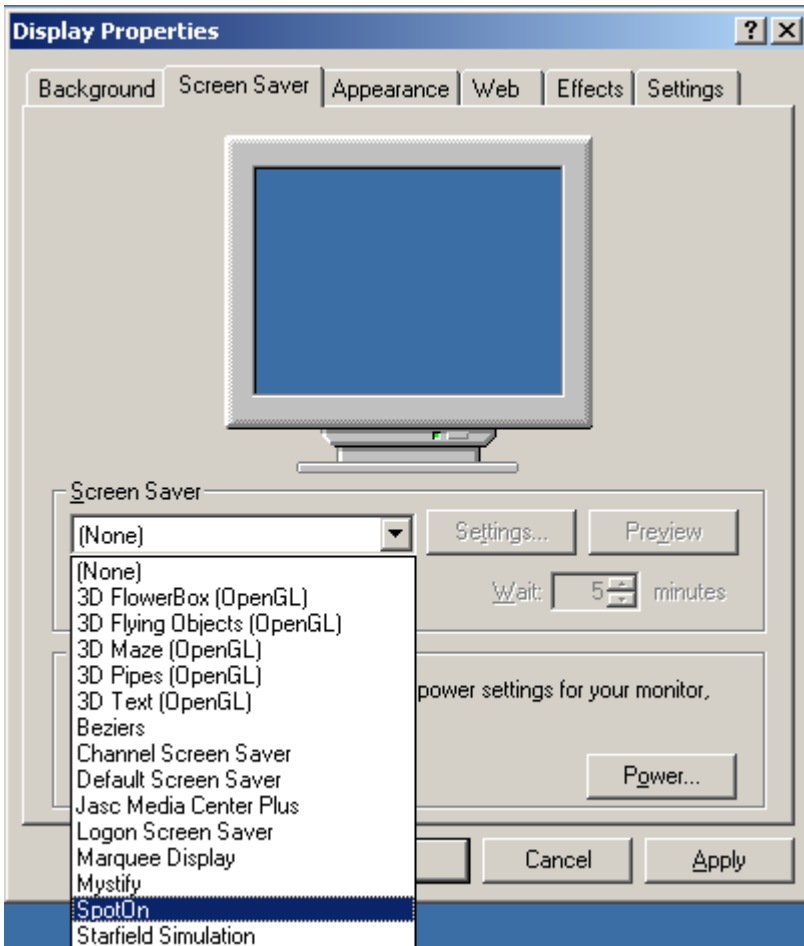

On selecting the SpotOn screen saver a preview will appear in the dialog box

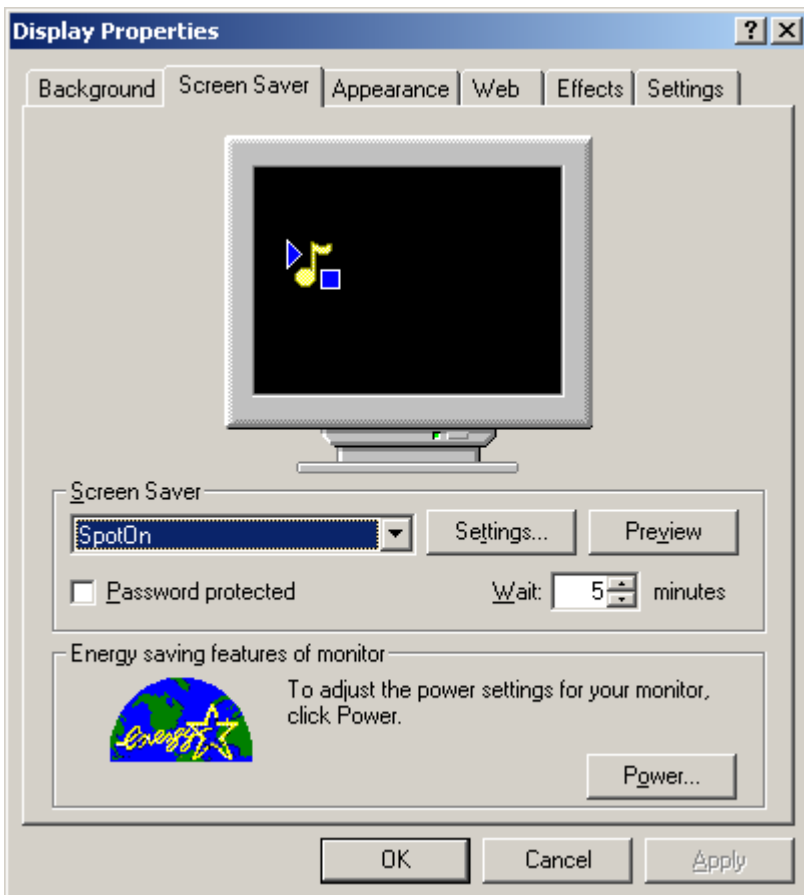

The screen saver display options can be accessed by clicking on the 'Settings...' button, there are only two parameters to adjust - Horizontal and Vertical speed. The 'Test' button displays the screen saver full screen mode in order to see the effects of the settings.

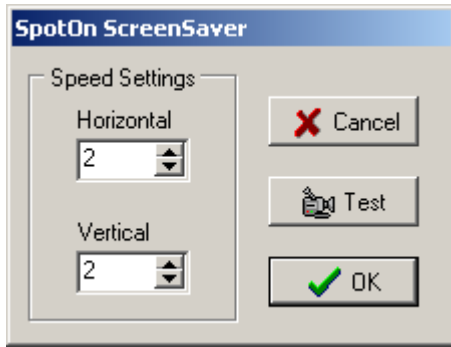

Click on OK on both dialog boxes to change to the SpotOn screen saver

# Sound Card Mixers

Computer Sound Cards have the ability mix audio from several sources into one output, the way this is implemented is not the same on all sound cards.

There are two main methods of mixing audio sources

- a,perform the calculation in software using the computer CPU
- b,perform the calculation in hardware on the sound card

The waveform display below shows the result of slowly fading out a 1kHz sine wave over 5 seconds, the steps in level can be clearly seen and heard, this fade was performed by the CPU in a Software Mixer.

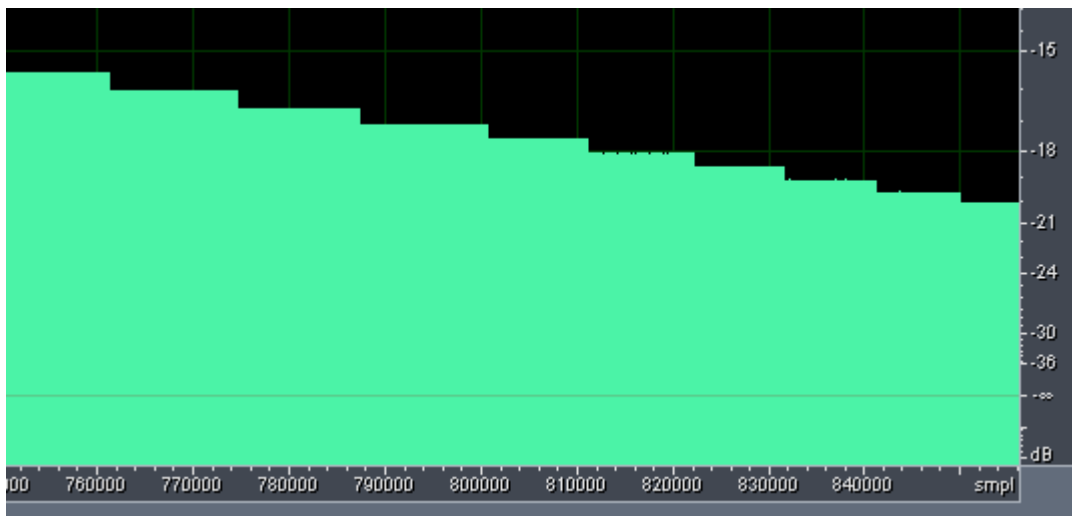

Below is the same fade operation, but this time performed by a Hardware Mixer on the sound card, the main difference is that the changes in level are made up of smaller steps, producing a much smoother fade.

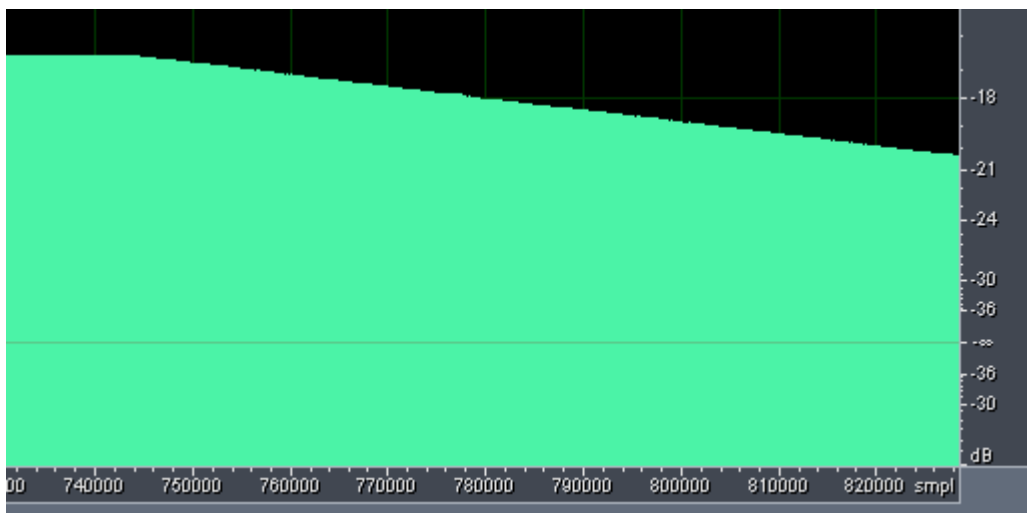

Another difference between Software and Hardware mixer can be seen when the level changes during the fade are examined in detail

In the Software Mixer the level changes are instantaneous causing harmonic distortion represented by clicks on the output

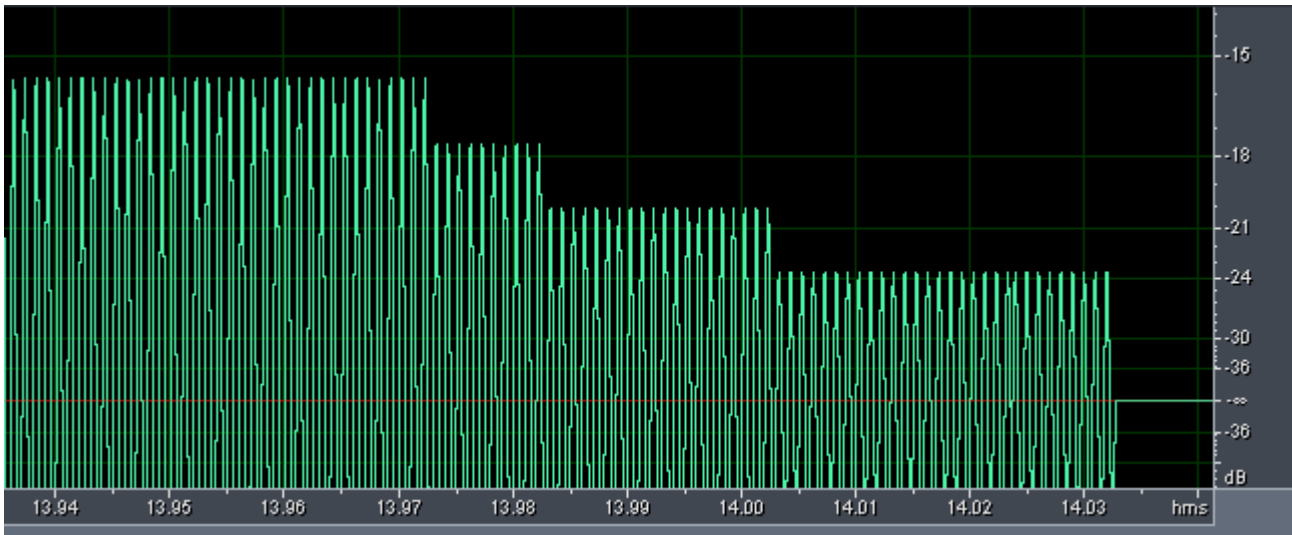

However when using the Hardware Mixer the level changes are ramped over a 5mS period so much reducing the audible distortion during the fade

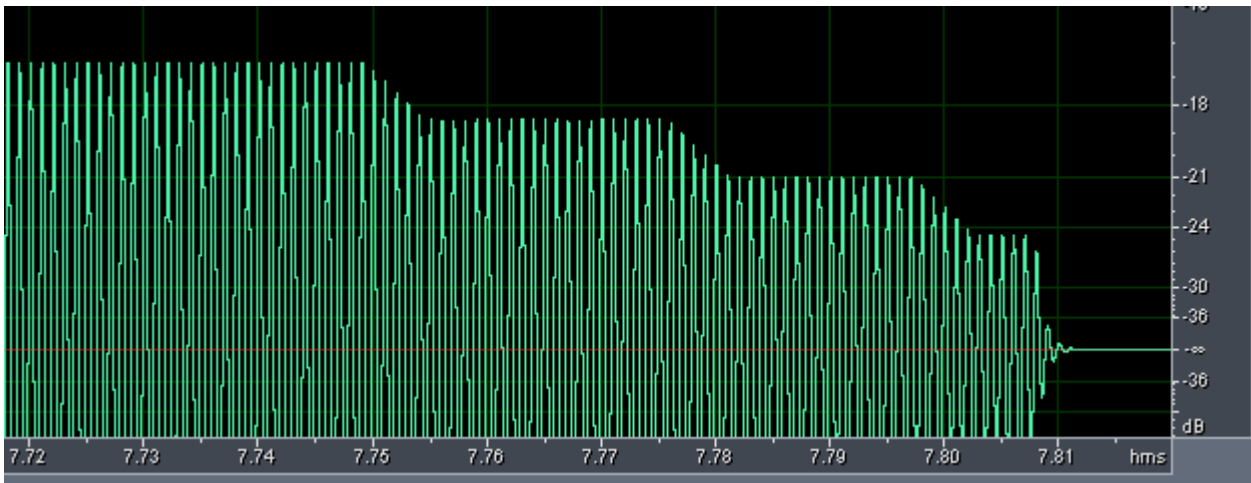

So in conclusion it is preferable to take advantage of any Hardware Mixers that may be available, the Info|Status menu option will list the facilities offered by the installed sound output devices

Below is the result of interrogating an On-Board sound card, which reports under "Maximum Hardware Mixing - all buffers" a value of 1. This means that only the first sound track loaded will be played out via a Hardware Mixer, all others being handled in a Software Mixer

```

Supports hardware mixed secondary 16 bit buffers
Supports hardware mixed secondary 8 bit buffers
Supports hardware mixed monophonic buffers
Supports hardware mixed stereo secondary buffers
Maximum hardware mixing - all buffers = 1
Minimum hardware mixing - static buffers = 1
Minimum hardware mixing - streaming buffers = 1
Free hardware mixing - all buffers = 0
Free hardware mixing - static buffers = 0
Free hardware mixing - streaming buffers = 0
Maximum hardware 3D - all buffers = 0
Maximum hardware 3D - static buffers = 0
Maximum hardware 3D - streaming buffers = 0

```

Similarly interrogating an external sound card reports under "Maximum Hardware Mixing - all buffers" a value of 64, meaning the first 64 sound tracks loaded will be played out via a Hardware Mixer and any subsequently loaded tracks via the Software Mixer

Supports hardware mixed secondary 16 bit buffers  
Supports hardware mixed secondary 8 bit buffers  
Supports hardware mixed monophonic buffers  
Supports hardware mixed stereo secondary buffers  
Maximum hardware mixing - all buffers = 64  
Minimum hardware mixing - static buffers = 64  
Minimum hardware mixing - streaming buffers = 64  
Free hardware mixing - all buffers = 63  
Free hardware mixing - static buffers = 63  
Free hardware mixing - streaming buffers = 63  
Maximum hardware 3D - all buffers = 64  
Maximum hardware 3D - static buffers = 64  
Maximum hardware 3D - streaming buffers = 64

The menu option Global|Optimize Tracks will reload all the audio tracks such that the most frequently used tracks are allocated to Hardware Mixers. This option would be used between a rehearsal and a recording as at that time SpotOn would have recorded the track usage

# Audio Processing

SpotOn uses the Windows sub-system to process the audio signals and pass them onto the Sound Card, this sub-system has two parameters that are access via the Control Panel, Sound and Multimedia applet.

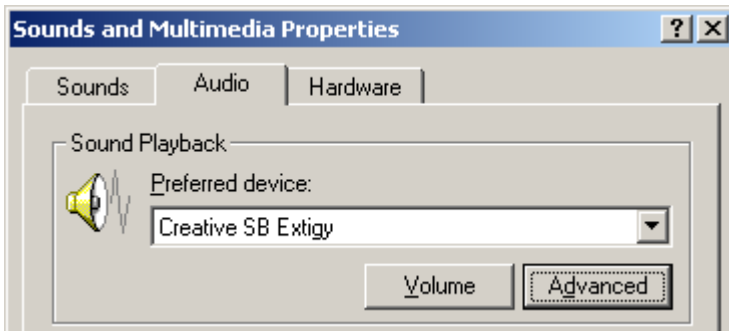

On the Audio tab select Advanced, then the Performance tab



The settings should be as above, a description of the options follows (extracted from Microsoft documentation).

## Hardware Acceleration

### None

Forces DirectSound into emulation mode. In this mode, DirectSound applications run as though no DirectSound driver is present. All mixing is done by DirectSound in user mode, and the resulting audio data is played back through the waveout API, the result is typically a large increase in latency.

### Basic Setting

The Basic setting disables hardware acceleration of DirectSound secondary buffers. Under this setting, all

DirectSound applications run as though no hardware acceleration is available, regardless of the capabilities of the sound card that is being used.

### Standard Setting

The Standard setting enables hardware acceleration of DirectSound secondary buffers but disables vendor-specific extensions such as EAX (Creative Technologies' environmental audio extensions)

### \*Full Setting

The Full setting enables full acceleration of DirectSound secondary buffers. This is the default setting in Windows 98/Me and Windows XP.

## **Sample Rate Conversion Quality**

### Good

Uses linear interpolation to achieve reasonable accuracy if converting similar sampling rates; for example, converting a 12-kHz rate to a 13-kHz rate.

### Multipoint interpolation

Uses a simplified version of high-end multipoint interpolation to achieve a signal-to-noise ratio of approximately 70 decibels.

### \*Best

High-end multipoint interpolation, uses oversampling to achieve a signal-to-noise ratio greater than or equal to 90 decibels.

## **Sample Rate Conversion Process**

SpotOn sets up the Windows sub-system (WSS) sampling frequency to be 48kHz or 44.1kHz, (the default value is 48kHz).

The WSS negotiates with the sound card and establishes a sample rate for the transfer of audio data, it assigns a sample rate corresponding to the higher of 44.1 kHz and the highest rate available on the audio device. (In Microsoft® Windows XP SP1, Windows Server 2003, and later, the highest sample rate supported is 200 kHz)

When SpotOn requests connection of an audio stream to a device, the WSS queries the device to determine whether it supports the incoming rate. If the device supports the incoming rate, the WSS passes the incoming stream to the device without Sample Rate Conversion (SRC). Otherwise, the WSS maintains the current output rate, and the WSS uses SRC to convert the input rate to the current output rate.

The table below set out the process for handling audio streams sampled at different frequencies.

New incoming rate is equal to the current output rate.	Perform mixing only.
New incoming rate is equal to the rate of another input stream.	Mix the new input stream with the other input stream at the same rate to take advantage of the existing SRC from input to output.
New incoming rate is lower than the current maximum input rate.	Do SRC to the current output rate and mix.

<p>New incoming rate is higher than the current maximum input rate.</p>	<p>If the hardware supports the new input rate:</p> <p style="padding-left: 40px;">Change the current maximum output rate and the hardware rate to the new incoming rate.</p> <p style="padding-left: 40px;">Do SRC on all other streams to the new maximum output rate and mix them with the new stream. (When converting to the new maximum output rate, the WSS mixes together any input streams that happen to share the same sample rate <i>before</i> doing SRC on those streams.)</p> <p>If the hardware does not support the new input rate, maintain the current output rate and do SRC on the new incoming stream to the current maximum input rate.</p>
---	--

### Sound cards with locking reference

With sound cards that have locking reference inputs, it is most likely that the WSS will have to convert all audio streams to the sample frequency set by the sound card locking feed. In this case the WSS cannot take advantage of the higher (oversampling) rates available in the sound cards without locking feeds. This results in a degraded SRC performance appearing as a loss of absolute frequency accuracy, for instance a 1000Hz tone might replay at 1012Hz when converting from a 8kHz sample rate to 48kHz.

This explains why professional sound cards with AES reference feeds (44.1kHz,48kHz) cannot achieve the accurate SRC of a lesser card which might have a very wide range of acceptable sampling frequencies (8kHz..200kHz).

# Decoders

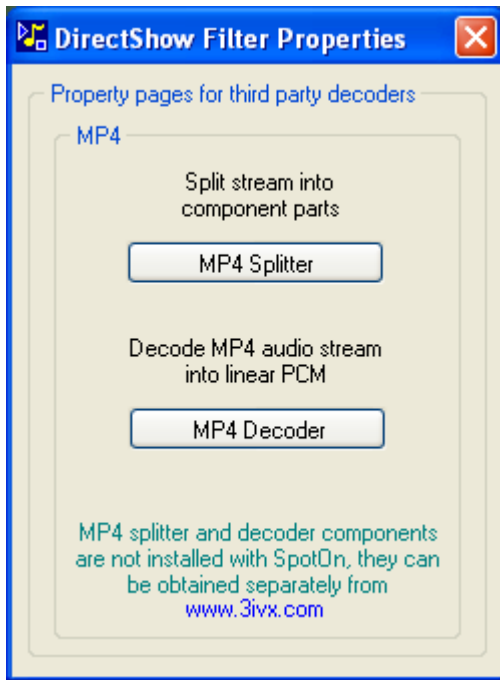

## MP4

There are no MP4 decoders installed with SpotOn, however it is configured to work with the 3ivx range of MP4 decoder utilities, these can be obtained from [www.3ivx.com](http://www.3ivx.com) and installed separately.

Examples of the property pages are shown below.

## MP4 Splitter



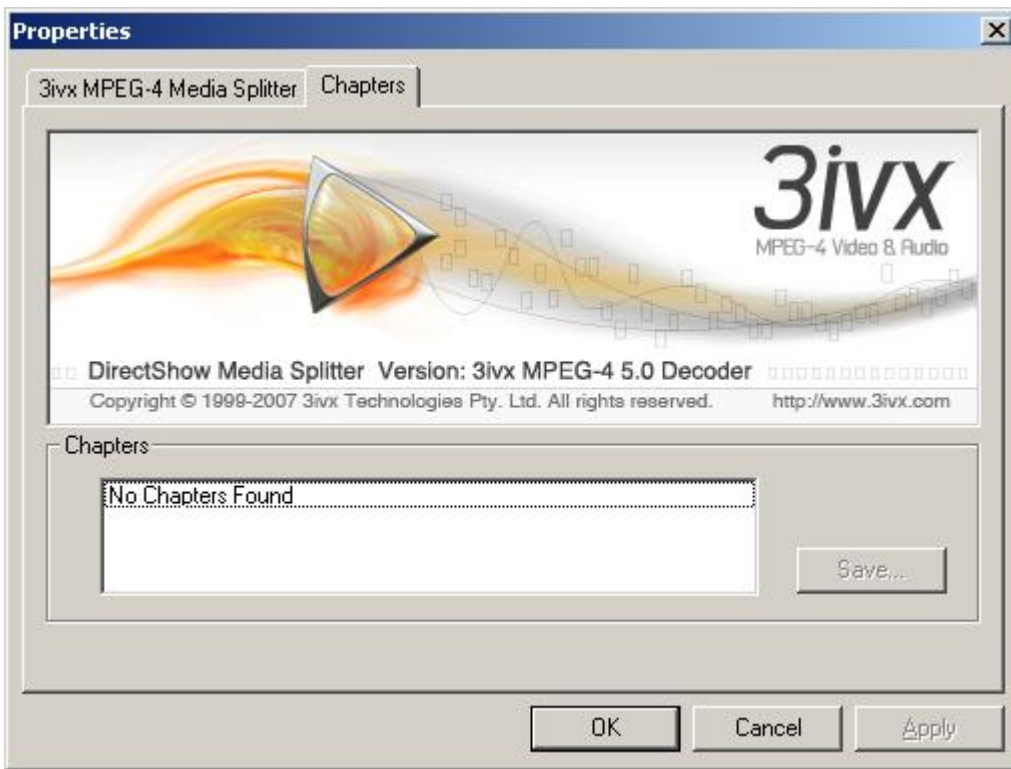

#### MP4 Decoder

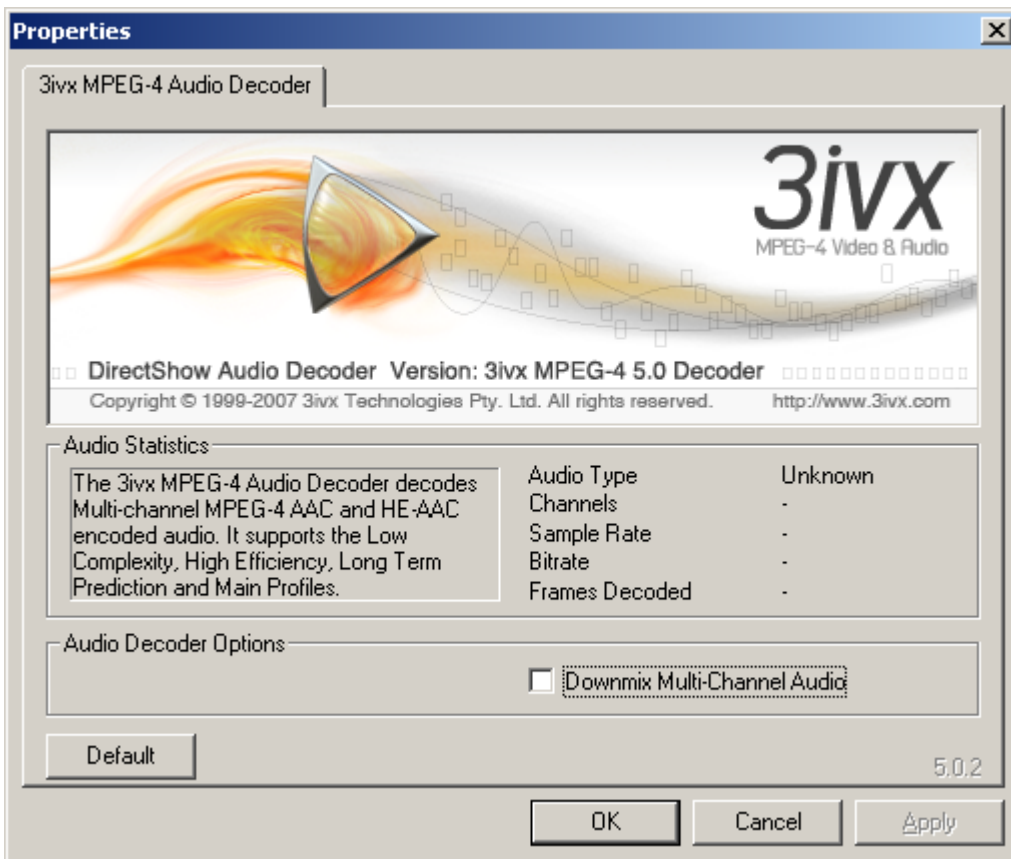

# Audio File Types



Flac is a open source Lossless Compression method, basically it's a zip file for music. When these files are decompressed, they are an exact match of their original wav files that was used to compress the file.

<http://sourceforge.net/projects/flac>



Microsoft Windows Media audio compression system

<http://www.microsoft.com/windows/windowsmedia/forpros/codecs/audio.aspx>



MP3 compression

<http://www.iis.fraunhofer.de/EN/bf/amm/projects/mp3/index.jsp>



**Mp4**

MP4(ACC) compression

<http://www.iis.fraunhofer.de/EN/bf/amm/projects/mpeg/index.jsp>



AC3 filter project

<http://ac3filter.net/>

# BLITS - 5.1 Surround Sound Ident

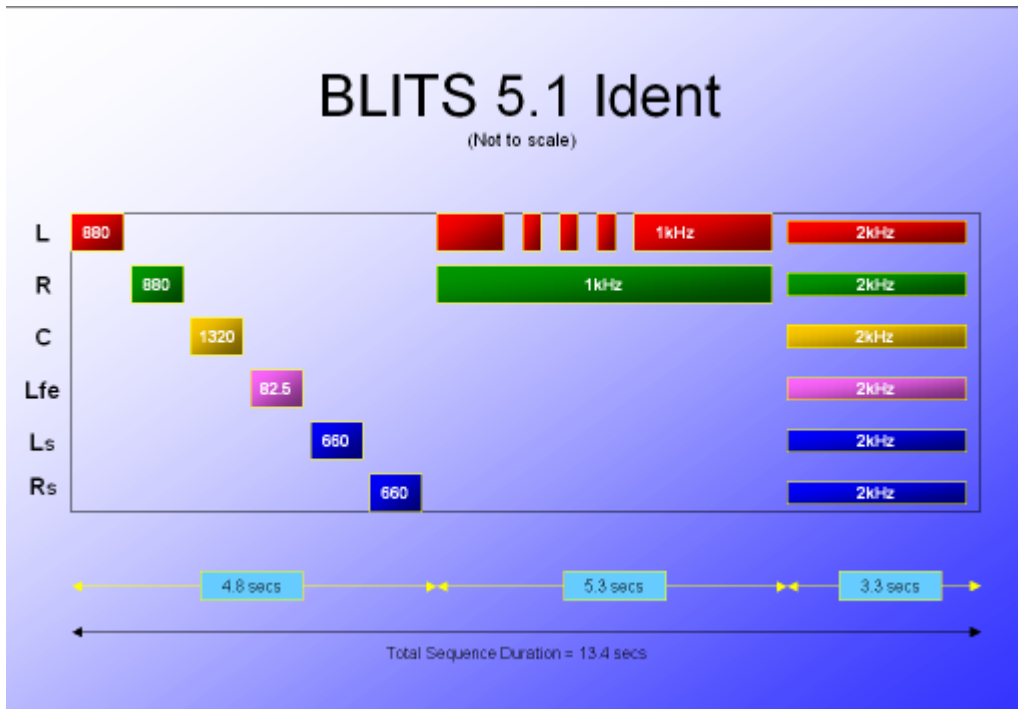

Notes on the derivation of the BLITS tone sequence © B Sky B 2007

It was in Autumn 2004 when Martin Black and Keith Lane, two of Sky Television's Senior Sound Supervisors, began to plan the implementation of 5.1 surround sound for Sky Sports' imminent live HDTV service.

One of the many and varied requirements which they identified early on in the project was a method of lining up in 5.1. It needed to be quick and simple to use and interpret, but effective and foolproof at the same time.

But it wasn't going to be quite that simple. Sky needed to derive a stereo Lt/Rt downmix from the 5.1, to provide the audio to accompany the simultaneous SD transmissions. This was to be achieved using Dolby DP563 prologic encoders, alongside the DP571 Dolby E encoders. So any ident format used would also need to work when folded down in this way, so as to make sense when only the stereo result was visible.

## Problems with EBU Tech-3304 (2005)<sup>[2]</sup>

We identified three potential problems with the only current EBU document on multichannel lineup, the EBU Tech-3304 (2005) multichannel audio lineup tone. [\[2\]](#)

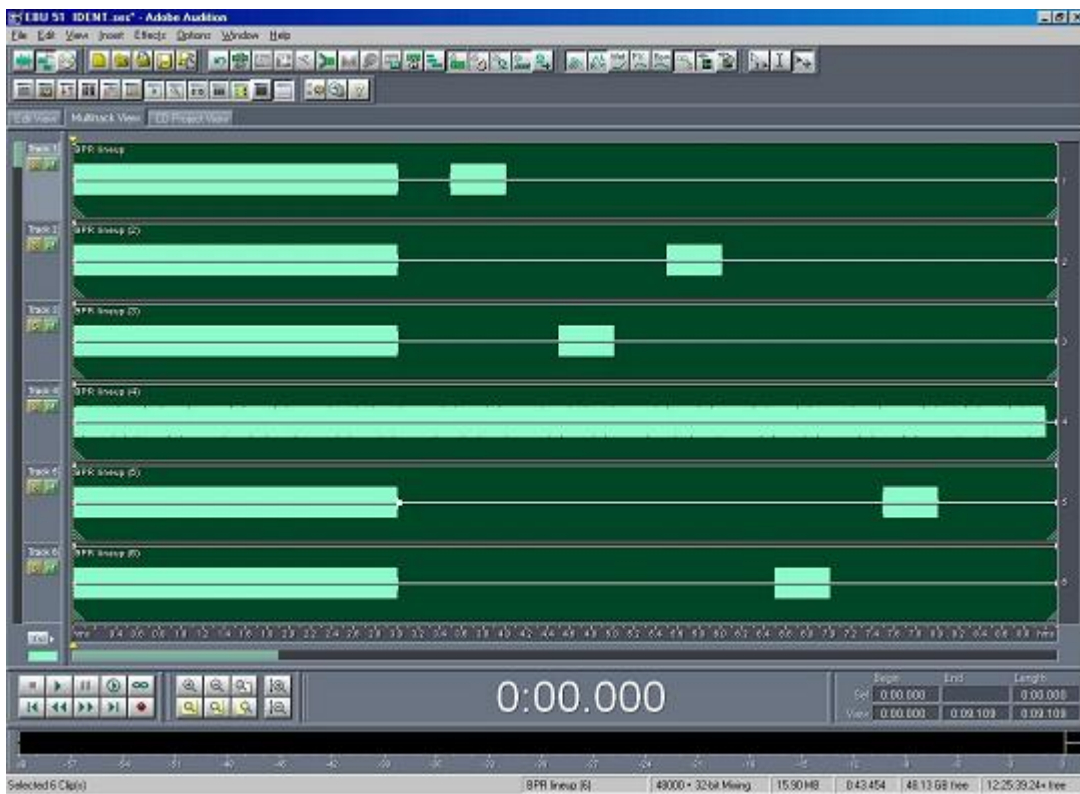

Figure 1: Adobe Audition screenshot:  
**EBU Tech 3304, in track-order: L, R, C, LFE, Ls, Rs**<sup>[2] [3] [4]</sup>

## 1: Folddown

In the same way that adding in-phase left and right of stereo results in a 6dB level increase, so the issue of adding together (downmixing) up to six legs of a 5.1 signal needs careful consideration to avoid a similar, or potentially greater, resultant level increase with the stereo (and mono) folddowns.

The EBU Tech-3304 sequence was not considered to be suitable for Sky's requirements as it starts with 1kHz zero-level tone in-phase on the five mains legs simultaneously, along with 80Hz on the LFE channel.

[Incidentally, most 5.1-capable sound desks do a similar thing when tone-to-line is selected to a 5.1 output, so beware!]

Depending on the coefficients set in the folddown matrix, the resultant 'stereo' downmix could have the tones of the other four legs (C, LFE, Ls, Rs) added to the front L and R with little or no attenuation. This is clearly going to result in the stereo folddown being at an undesirably high level.

However, It was thought necessary to have an identical signal on all legs simultaneously at some point in the sequence, if only to provide a phase-check capability.

The BLITS ident achieves this with the third section of the sequence - a 2kHz tone on all legs, but at -6dBu (or -24dBfs).

[See Fig-3 below for the stereo folddown levels which result.]

## 2: Identing the individual channels

EBU Tech 3304 uses the same 1kHz tone to ident each of the legs. But steady single frequency tone is notoriously poor at providing directional clues to the ear. Secondly, and arguably more importantly, it

does not identify the legs in the order specified for broadcasting, but instead uses the older Film standard. [EBU Tech R48]

On the face of it this appears to be more useful when listening to the ident sequence on a 5.1 speaker system, as it cycles through the speakers sequentially in a clockwise direction. That's fine until you see it on a surround bargraph-type meter (e.g. a TFT display) where it jumps around confusingly rather than being sequentially left to right across the meter-legs

To solve these two problems, BLITS uses different tones for the various channels, and the order of tones in the sequence now matches that of the broadcast standard.

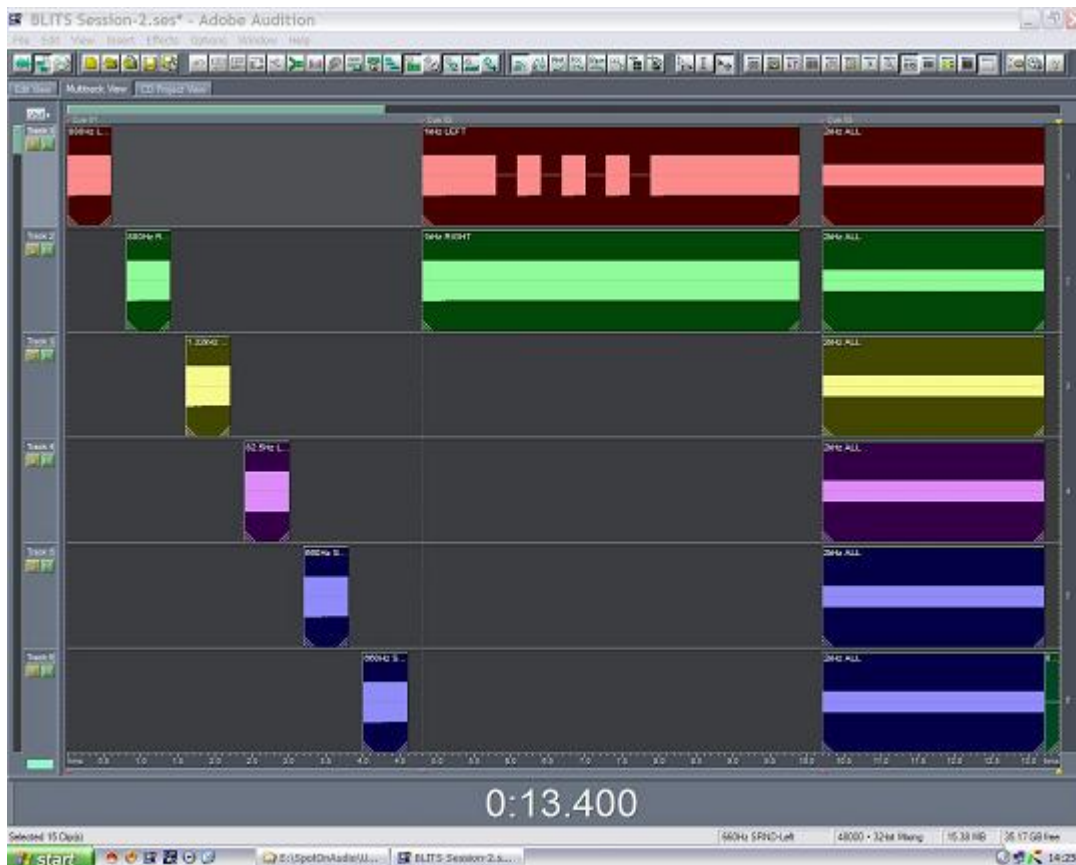

Figure 2: Adobe Audition screenshot:  
**The three sections of the BLITS ident, showing the sequence of components**

Track order (top to bottom) is: L, R, C, LFE, Ls ,Rs

The frequencies used are based on the international musical standard of 440Hz (A), and the interval of a perfect fifth above it (E)

The actual frequencies are:

- |            |              |
|------------|--------------|
| L = 880Hz  | R = 880Hz    |
| C = 1320Hz | LFE = 82.5Hz |
| Ls = 660Hz | Rs = 660Hz   |

Note that the sequence order also replicates the order of signals in the three 'stereo' pairs which make up the 5.1 signal in the digital broadcast world. [\[3\]](#) [\[4\]](#)

### 3: Making it easy in stereo too

Let's not forget that, even if you have the time/staff/facilities/necessity to create a stereo mix which is completely separate from the 5.1 (not likely to be the case with many live transmissions), HD viewers will still receive a metadata-controlled downmix of the 5.1 audio by virtue of the set-top box's stereo output being a fold-down mix.

This is currently the case on all Sky's HD platforms whenever an HD channel with 5.1 Dolby Digital sound is viewed with only stereo reproduction, such as when using a TV's stereo speakers fed via the STB's analogue SCART or digital HDMI output. So, even if a separate stereo mix is made by a broadcaster, it will not be heard by HD viewers listening in stereo.

Furthermore, on the Sky Sports' platform a simultaneous Lt/Rt fold-down, created by a Dolby DP563 prologic encoder, is used to deliver the stereo audio for the equivalent SD channel.

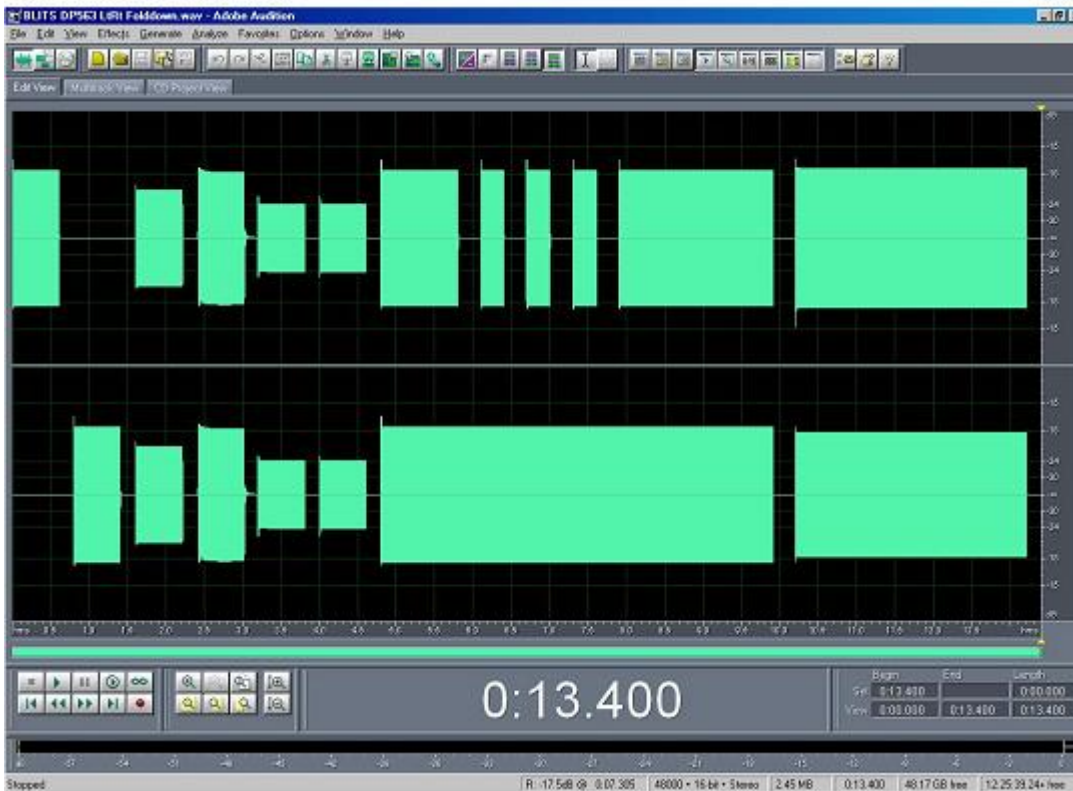

Figure 3: Adobe Audition edit screen - the vertical scale has been expanded for clarity  
**A 'real-world' fold-down of 5.1 BLITS sequence to Lt/Rt stereo (using a Dolby DP563 ProLogic encoder).**

The downmix level-parameters can be deduced from looking at the levels of the six individual legs of the sequence, seen in the first section of the screen-shot, on the left.

In this case the current Sky Sports downmix settings can be deduced, which are;

Centre	-3dB
LFE	0dB
Ls & Rs	-6dB

This is equally visible on a stereo PPM when viewing the downmix 'on-the-fly'.

To aid in gauging relative levels in figure 3, the middle 'stereo ident' section is at 0dBu, since it is not changed by the downmix process.

It can be seen from this that the third, 'phase-check', section also folds down to around zero-level - which is just what we wanted!

The fold-down level information is also programmed into the Dolby-E metadata, and thence in the Dolby Digital metadata. It is the latter which the set-top box uses to create its stereo output for HD viewers without surround systems.

The purpose of the middle, front L/R only section, is to provide a 'familiar' signal to operators - particularly transmission operators - with no experience of surround sound. They will only get to see the stereo downmix illustrated in figure 3. The first and last sections may mean little to them, but the middle '1kHz tone on L & R' is intended to strike a familiar chord (!).

The four breaks were needed because this was the minimum number which would differentiate a mono BLITS downmix from a mono EBU tone or GLITS tone downmix. Mono EBU (R49) produces a single level-dip, and mono GLITS produces three level-dips, so BLITS produces four. It also acts as another flag to the operator that the mix originated in 5.1.

## In Use

The almost daily use of the BLITS Ident in Sky Sports HD/5.1 transmissions has proved to be a great success, and its usability and diagnostic performance have exceeded expectations. It is regularly used for:

- OB Line-up with MCR and studios
- OB and Studio Line-up with Transmission suites
- OB and Studio Line-up with VTR and EVS machines
- Studio line-up of reverse circuits with MCR and OB units

Oh, and a slight variant of it was also used by Robert Edwards and Ian Rosam for all 5.1 surround lineups during the 2006 World Cup in Germany.

## Conclusions

BLITS is in almost daily use on over a dozen OB units in the UK to date, as well as in Sky's HD studios and MCR.

A 1RU commercially manufactured generator is available from CTP systems in Kent. [\[5\]](#)



Around twenty of these units are currently in use in the UK.

In addition to analogue and digital BLITS outputs, the CTP unit also provides a standard EBU R-49 stereo ident on front L/R as a switchable alternative output (by front panel switches and/or GPI inputs, with tallies).

A simultaneous, permanent EBU stereo output is also provided separately.

BLITS is also available as a 5.1 multichannel wav file from the author: [martin.black@bskyb.com](mailto:martin.black@bskyb.com) [*File size is about 2MB zipped*].

A 5.1 sound card is required to reproduce it correctly. A stereo-only card will generally only play back the front left and right channels.





Its copyright status is similar to shareware - it's licence-free to use, provided it's kept in its original form.

## References

- [1] [EBU Recommendation R49-1999](#): Tape alignment leader for the exchange of television programmes
- [2] [EBU Tech-3304](#): Multichannel Audio Line-up Tone
- [3] [EBU Technical Recommendation R91-2004](#): Track allocations and recording levels for the exchange
- [4] [EBU Technical Recommendation R48-2005](#): Allocation of audio tracks on digital television recorder
- [5] [CTP Systems](http://www.ctpsystems.co.uk): www.ctpsystems.co.uk

# MultiChannel Sound

In addition to 2 channel Stereo, SpotOn can handle multi-channel WAV files containing 1,2,4,6 or 8 channels of audio, these files are referred to as interleaved WAV files.

1	2	4	5.1	7.1	Ch	Name
					1	Front Left
					2	Front Right
					3	Front Centre
					4	Low Frequency
					5	Back Left
					6	Back Right
					7	Front Left of Centre
					8	Front Right of Centre
					9	Back Centre
					10	Side Left
					11	Side Right
					12	Top Centre
					13	Top Front Left
					14	Top Front Centre
					15	Top Front Right
					16	Top Back Left
					17	Top Back Centre
					18	Top Back Right

Larger configurations are used in Digital Cinemas up to 22.2 (24 loudspeakers) for interest the layout is:-

Upper layer: Nine speakers above ear level

Top Front Centre	Top Back Centre
Top Front Left	Top Front Right
Top Side Left	Top Side Right
Top Back Left	Top Back Right
Top Centre	

Middle layer: Ten speakers at ear level

Front Centre	Back Centre
Front Left of Centre	Front Right of Centre
Front Left	Front Right
Side Left	Side Right
Back left	Back Right

Lower layer: Five speakers below ear level

Left Sub Woofer	Right Sub Woofer
Bottom Front Left	Bottom Front Right
Bottom Front Centre	

# Sound Card SetUp

SpotOn uses Microsoft DirectX to interface with the soundcards, for this to work correctly the soundcard must have a WDM driver, if in doubt check the manufacturers specification for compatibility with 'DirectX', 'DirectSound' or 'WDM'.

If in the Admin|Output Assign menu there are entries with references to 'WAVE' or Emulated' then these output will most likely not perform correctly.

[Audio Science ASI504x](#)

[DigiGram VX422](#)

[Echo Gina 3G](#)

[Echo Layla 3G](#)

[Edirol UA-101](#)

[M-Audio Delta 1010](#)

[RME HDSP AES-32](#)

[RME HDSP MADI](#)

[RME Fireface 800](#)

[RME Multiface II](#)

## Audio Science ASI5041/2/4



**ASI5041** - 4 stereo inputs and 4 stereo outputs, AES/EBU digital only.

**ASI5042** - 4 stereo inputs and 4 stereo outputs, balanced analog only.

**ASI5044** - 4 stereo inputs and 4 stereo outputs, both balanced analog and AES/EBU digital.

The Audio Science sound card model ASI5042/4 is an 8 output card and can be configured as:-

4 x 2 channel o/p/s (Mode2) **or** 1 x 8 channel o/p (MultiChannel)

The selection is made using the Audio Science control utility, the computer must be rebooted after a change to reconfigure the sound card.

Multiple ASI5042 sound cards can be fitted to a PC, they are identified using header links on the sound card boards and will appear in the control utility window designated ASI5042-1, ASI5042-2....

The ASI5044 has AES digital and analogue inputs along with AES digital and analogue outputs, note that other than the 'Level' control the 'Volume' sliders have no effect on the AES inputs and outputs.

Highlight the appropriate adaptor and set the adaptor mode as shown below for either MultiChannel (MultiChannel) or Stereo (Mode-2)

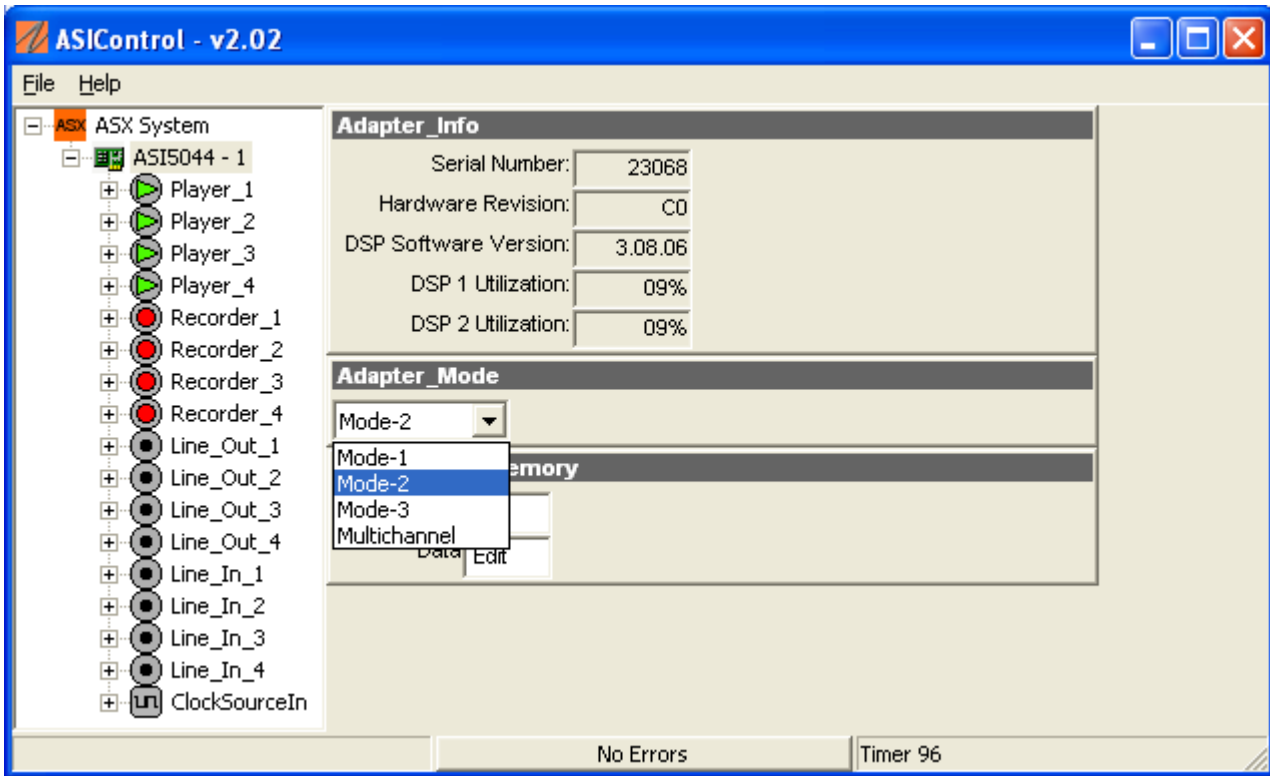
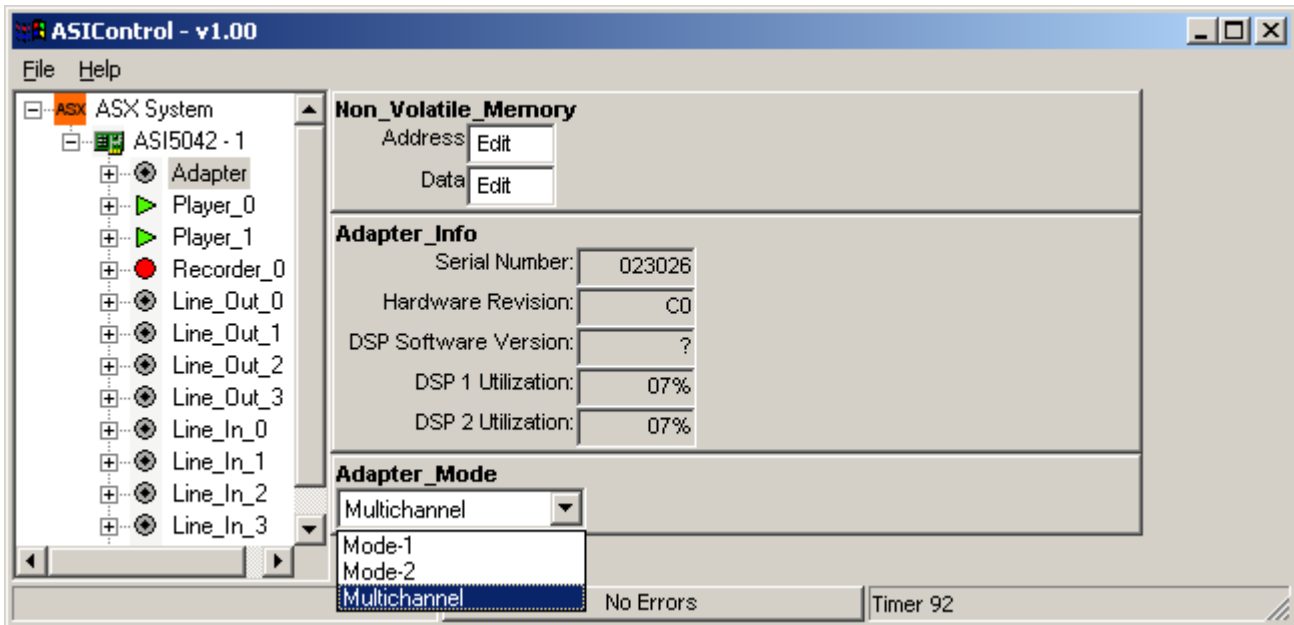

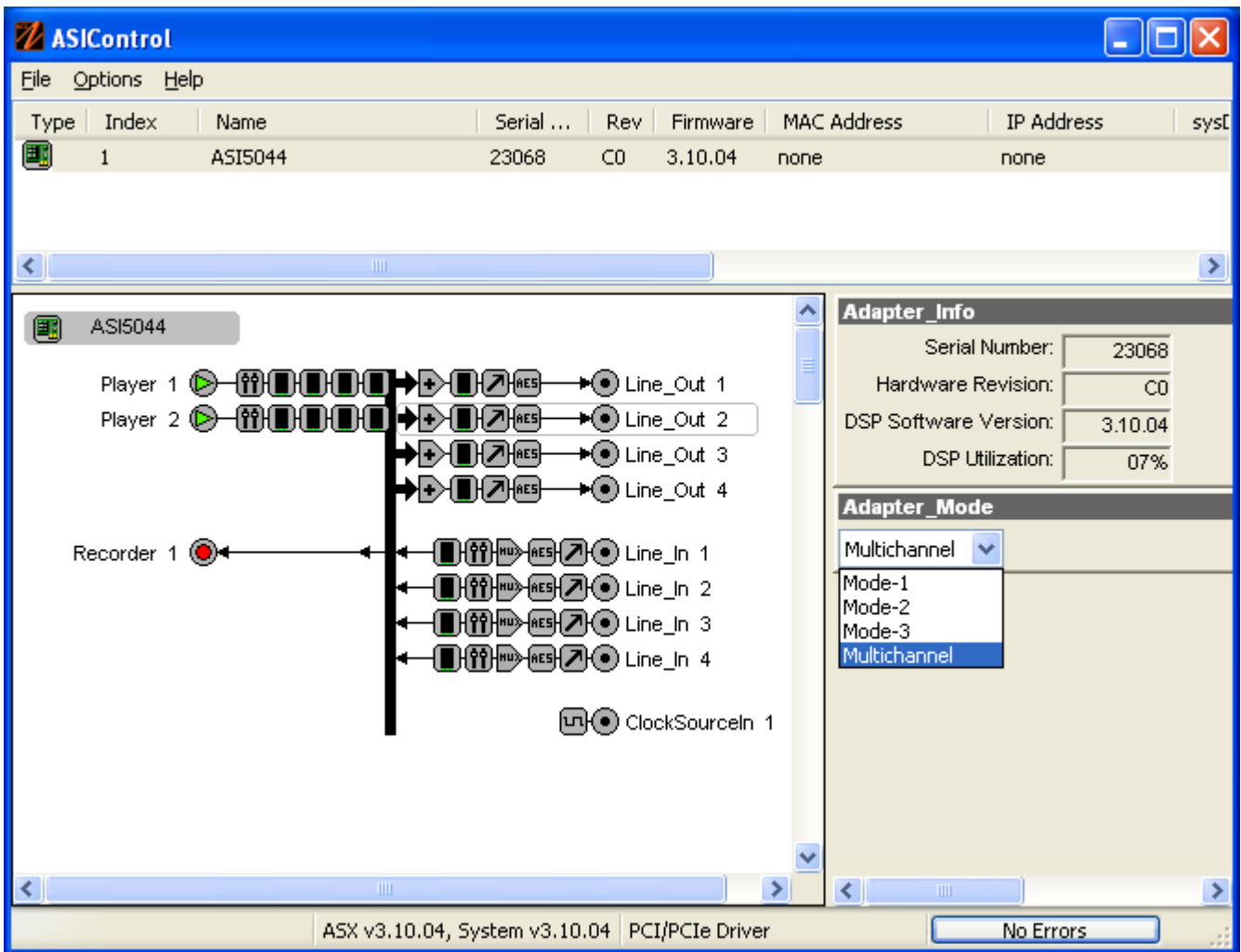

The card presents itself to SpotOn as a number of entries in the Output Devices list: -

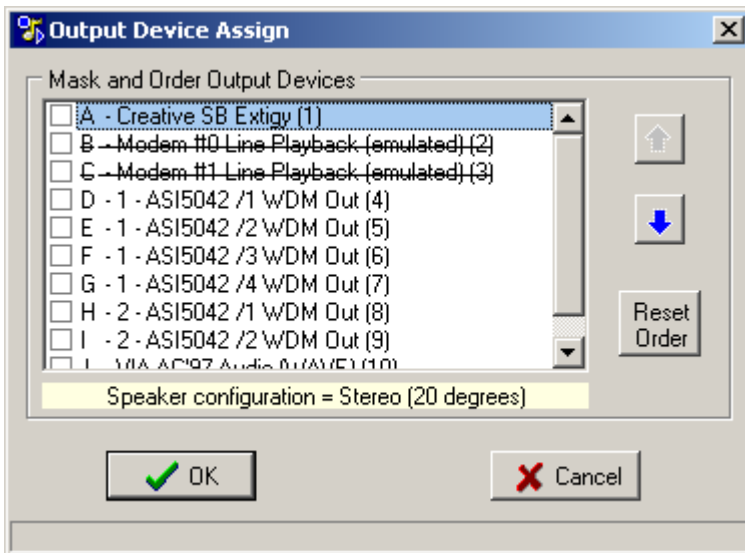

Here there are two cards in the system:-

Card 1 (4 x 2 channel) implements 4 stereo devices D, E, F, G

Card 2 (1 x 8 channel) implements 2 x 8 channel devices H, I

Both devices H and I can be used to access the multi-channel output as the two signals are mixed together by the sound card.

The reference clock source can be derived internally (Adaptor or Local), from a selected AES input (AES/EBU In x) or from the first available input with a valid AES signal (AES/EBU Auto).

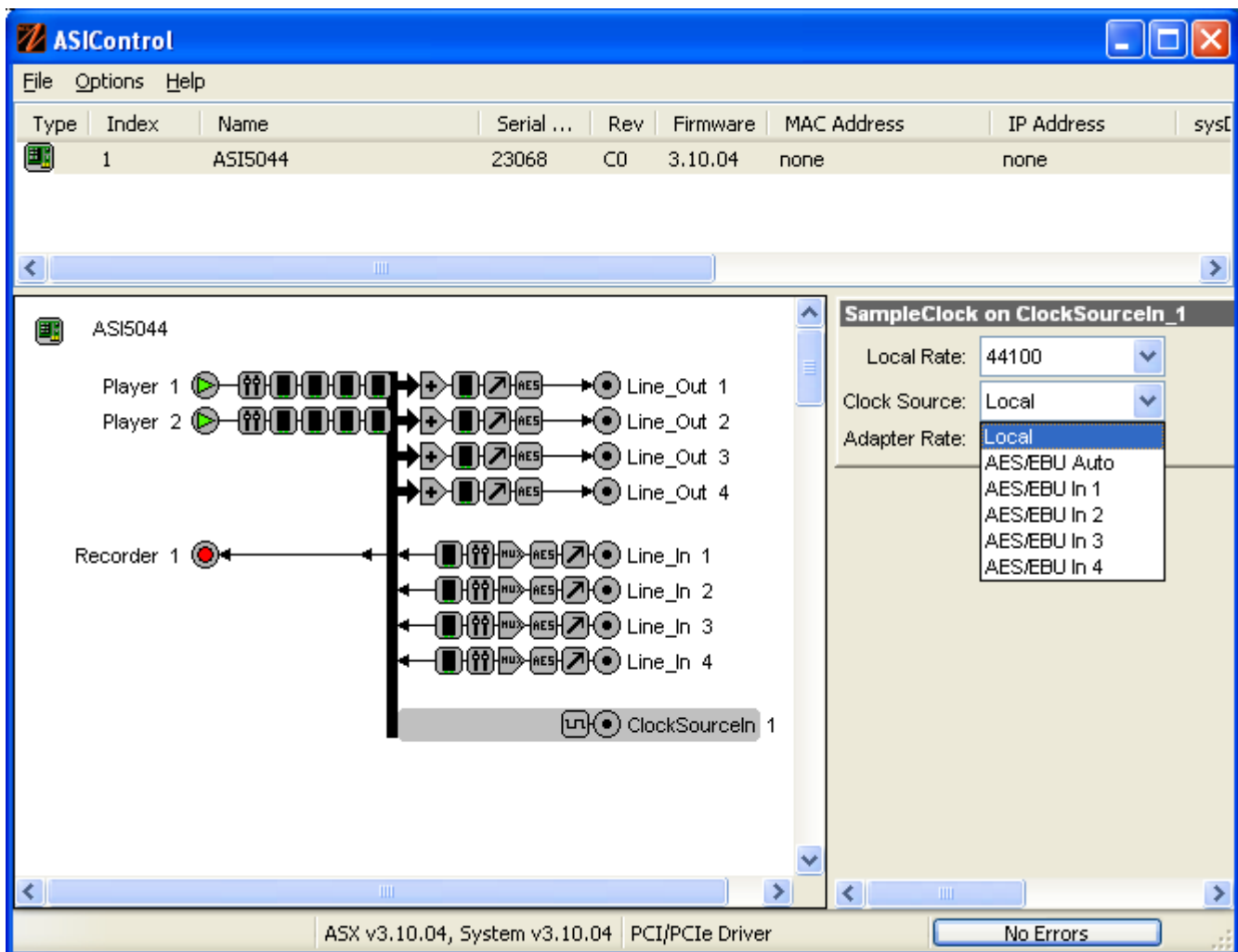
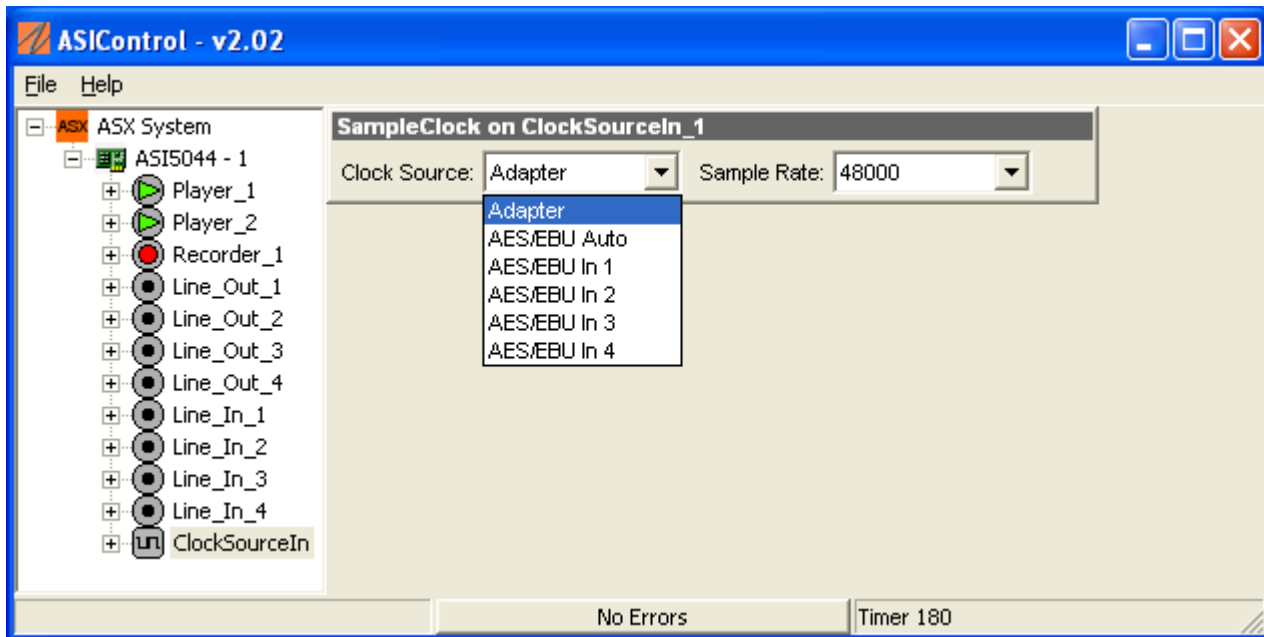

The local clock rate can be set to any of the standard values

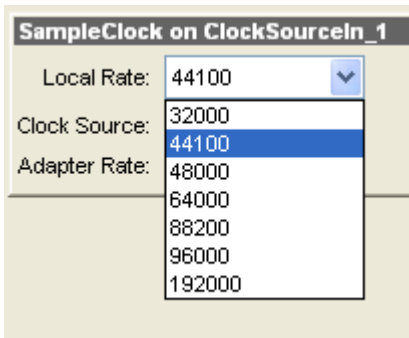

## MultiChannel

The image below shows the section controlling Player\_0 (device H), the meter bargraphs will show levels for the 8 channel audio and the volume slider setting the overall level of the contribution from Player\_0, there is a similar page for Player\_1 (device I).

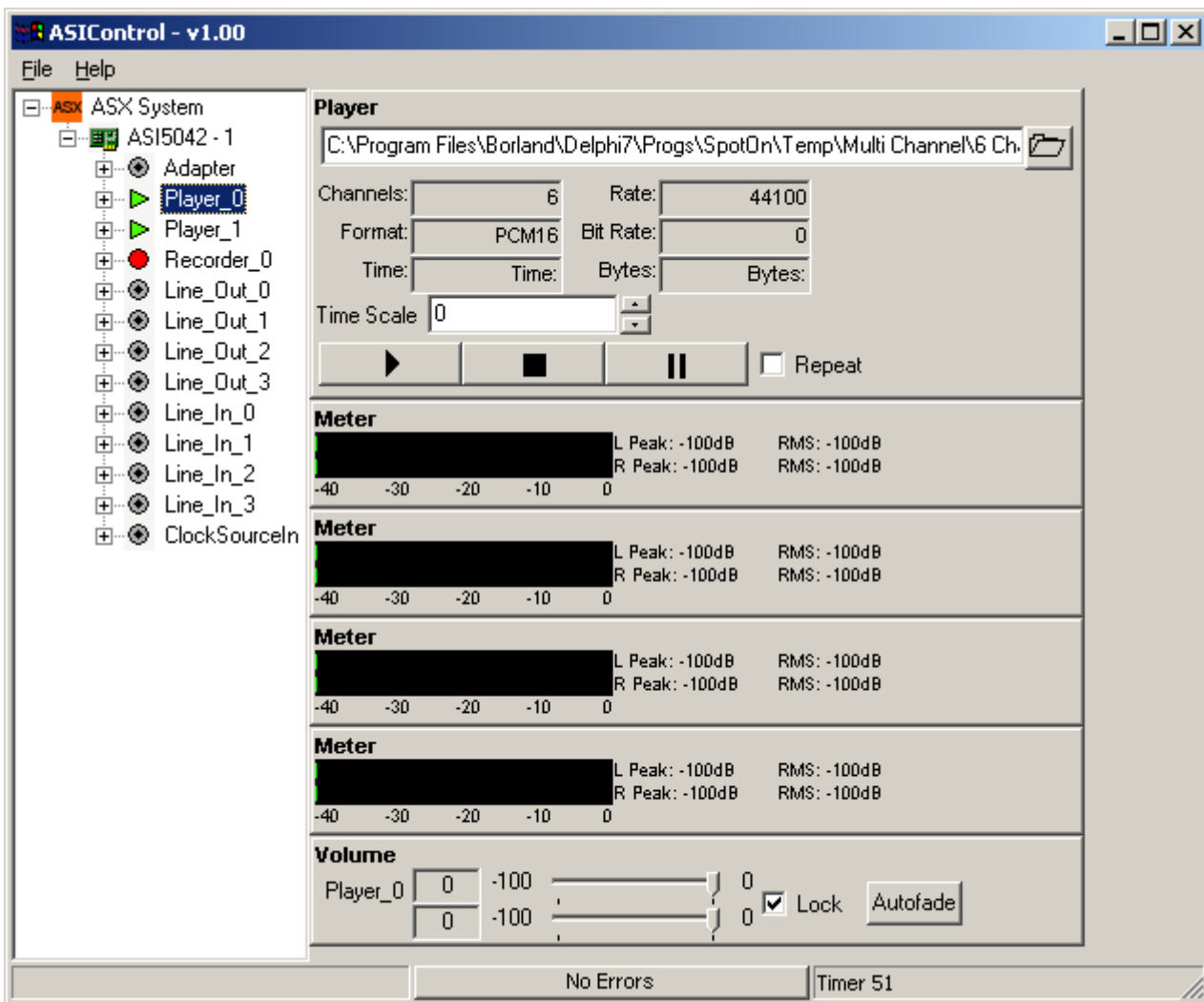

Note the later versions of the driver list the devices starting from 1 not 0



In multi-channel mode there are level controls for the four 2 channel outputs:-

Line\_Out\_0, Line\_Out\_1, Line\_Out\_2, LineOut\_3

The audio routed to these outputs is a mix of the input and the two player streams, for use with SpotOn both the volume slider for Player\_0 and Player\_1 should be set to maximum on all four outputs Line\_Out\_0..3 as shown below.

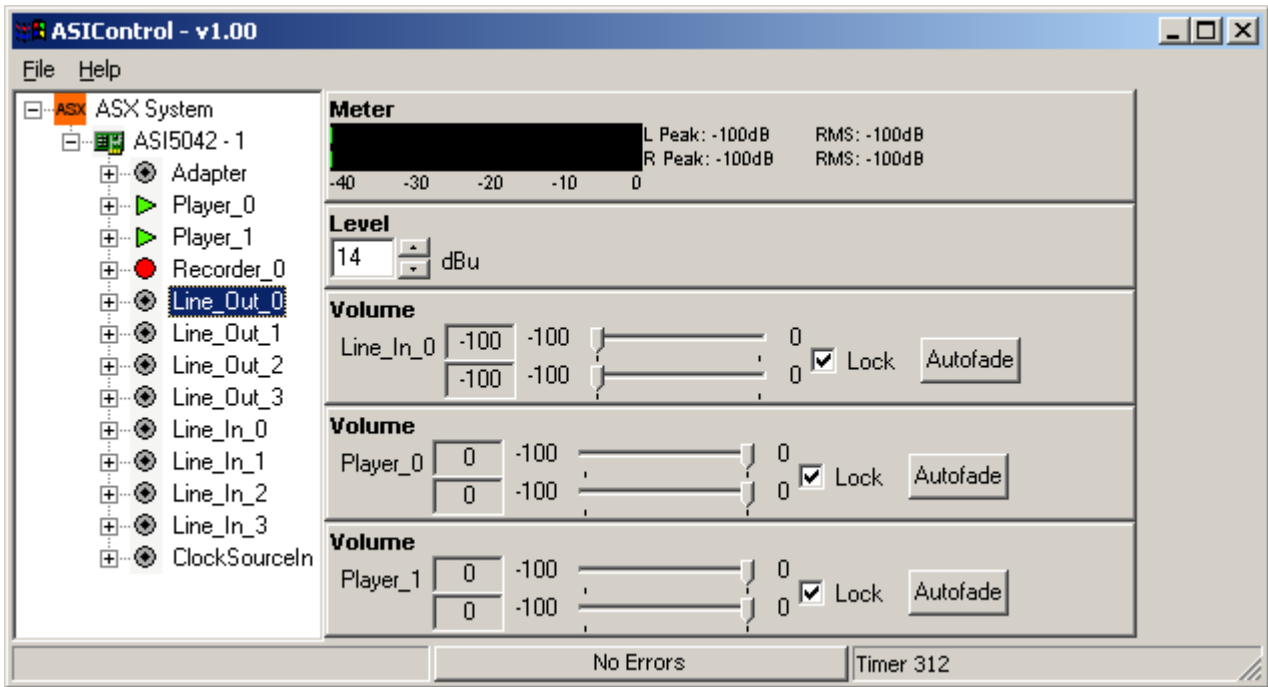

Note the later versions of the driver list the devices starting from 1 not 0

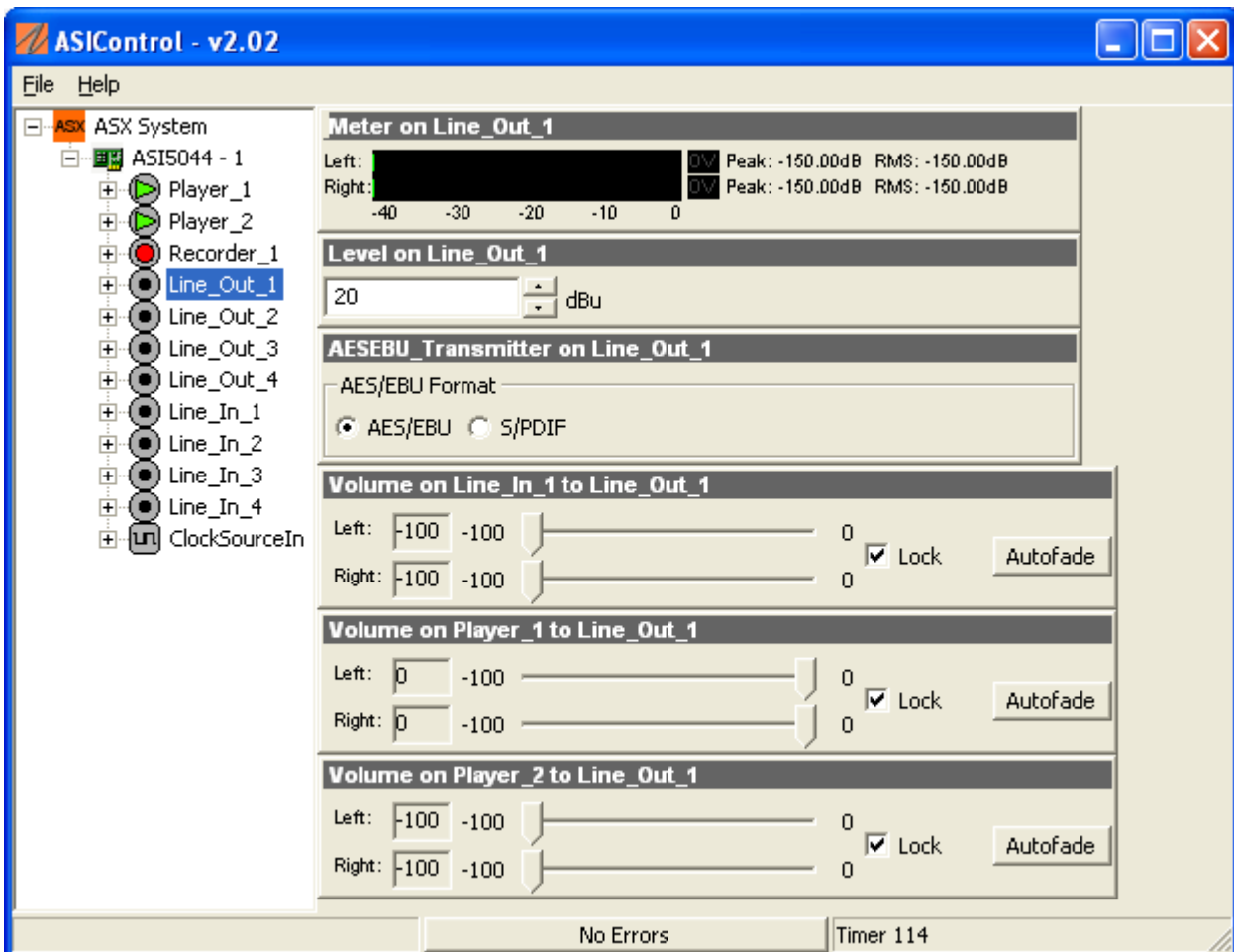

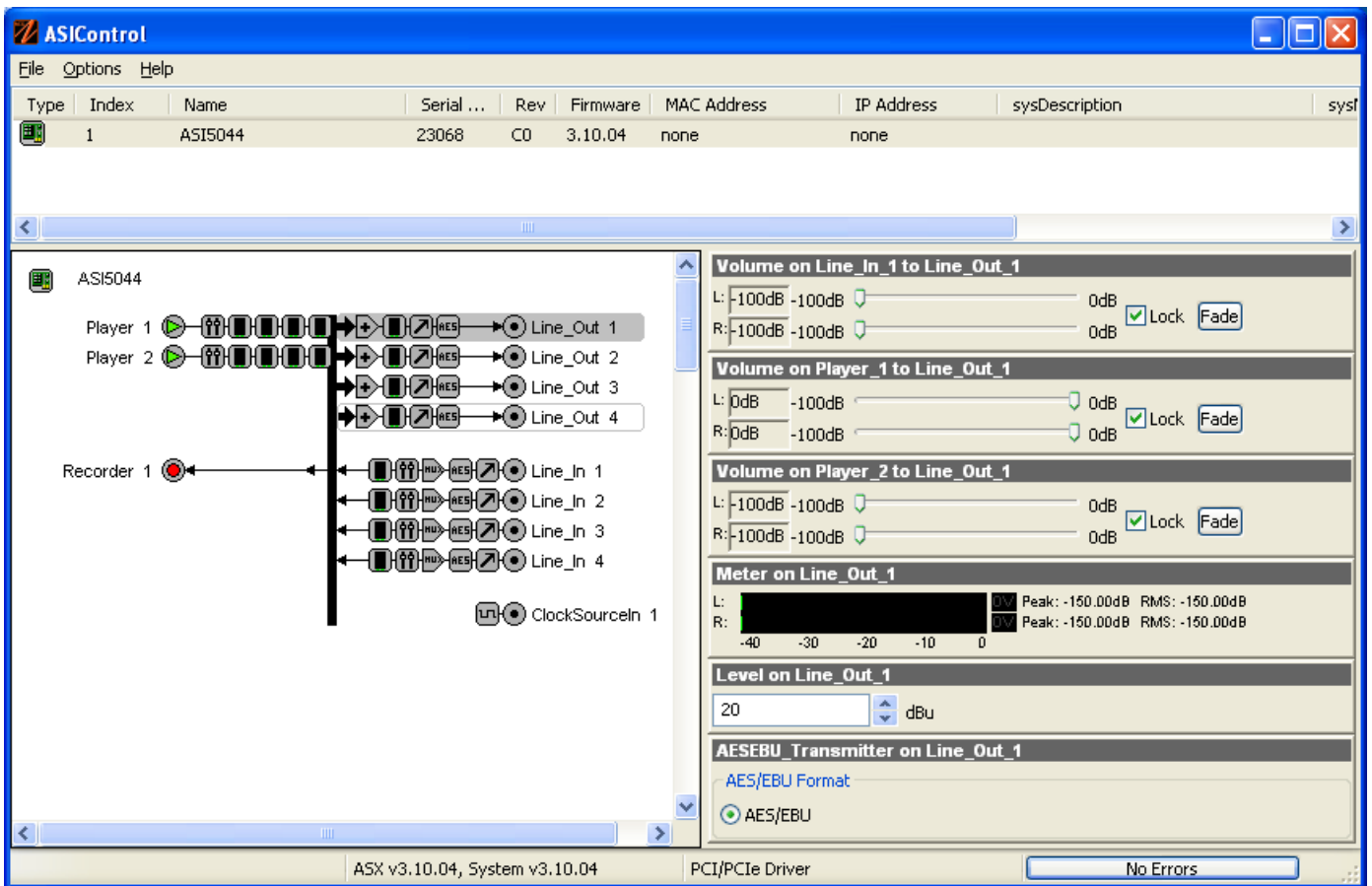

The Level control showing 14dBu in the upper window and 20 dBu in the lower windows sets the overall output level the nudge up/down buttons set the value so that a test file produces the correct level at the destination.

The Player\_0 and Player\_1 (Player 1, Player 2) volume controls above operate as live controls on the output level, however their settings are not restored after a restart of the PC - this is due to the levels being overwritten by the operating system. The levels used by the operating system are those set in the Control panel.

Select Control panel

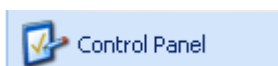

then the Sounds and Audio Devices applet



select the Audio tab

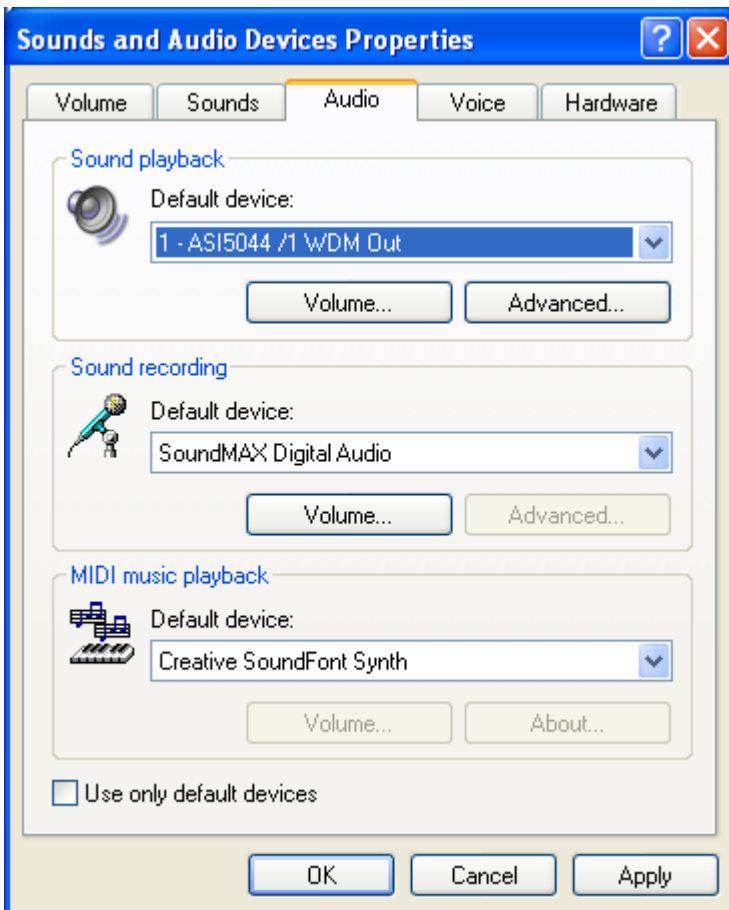

then select Volume button in the Sound Playback section.

The Windows volume controls have a different look when an AudioScience card is selected and it is set to MultiChannel mode, notice the Speaker Volume button on the left hand side.

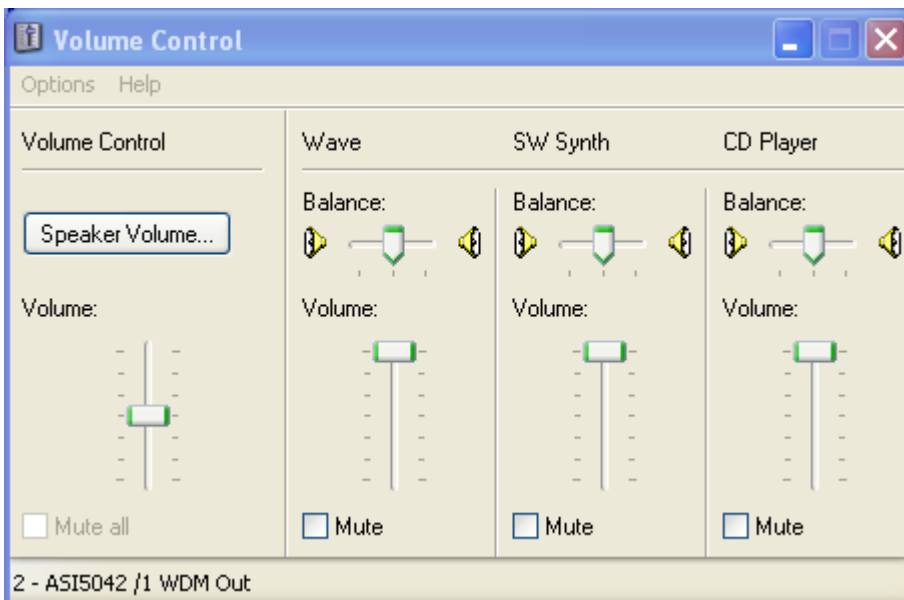

The Speaker Volume button displays a set of volume sliders for all the eight outputs of the device, these are the settings that are restored on a restart of the PC. Consequently the output levels have to be adjusted in this window, however it is usually sufficient to set all eight sliders to maximum.

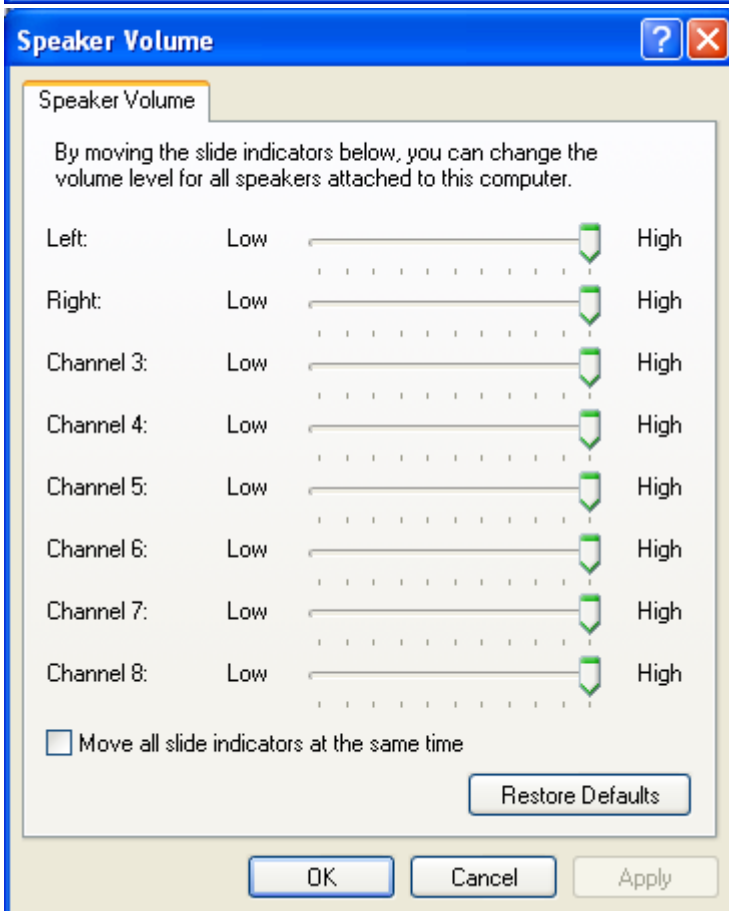
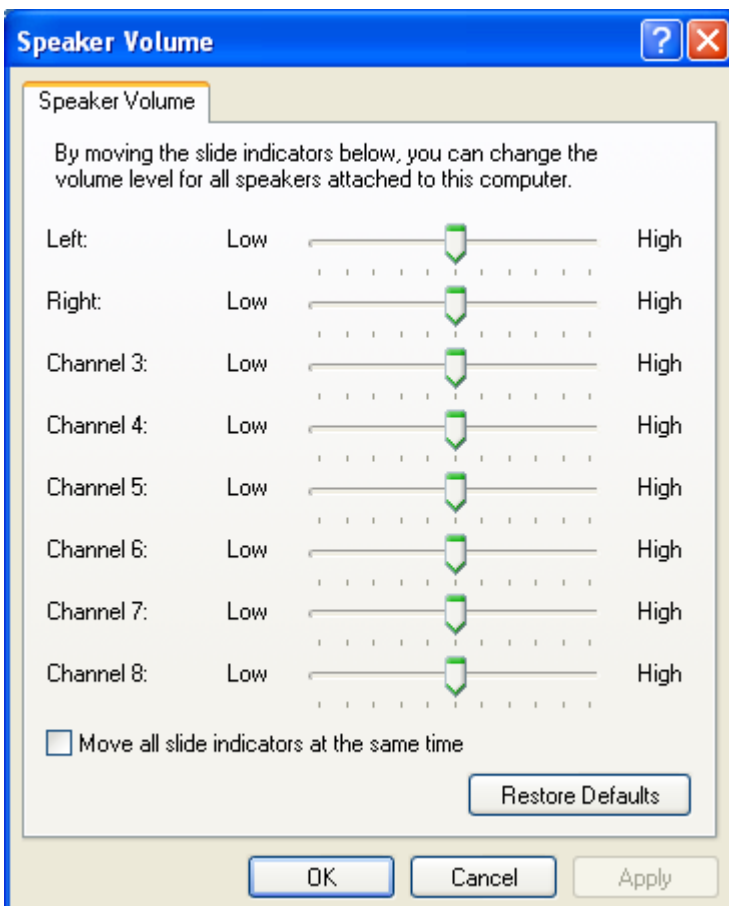

## Stereo

In Mode 2 (4 x Stereo) there are four 2 channel devices implemented, designated Player\_0, Player\_1, Player\_2, Player\_3, the image below shows the settings for Player\_0 (device D), here the volume slider should be set to maximum.

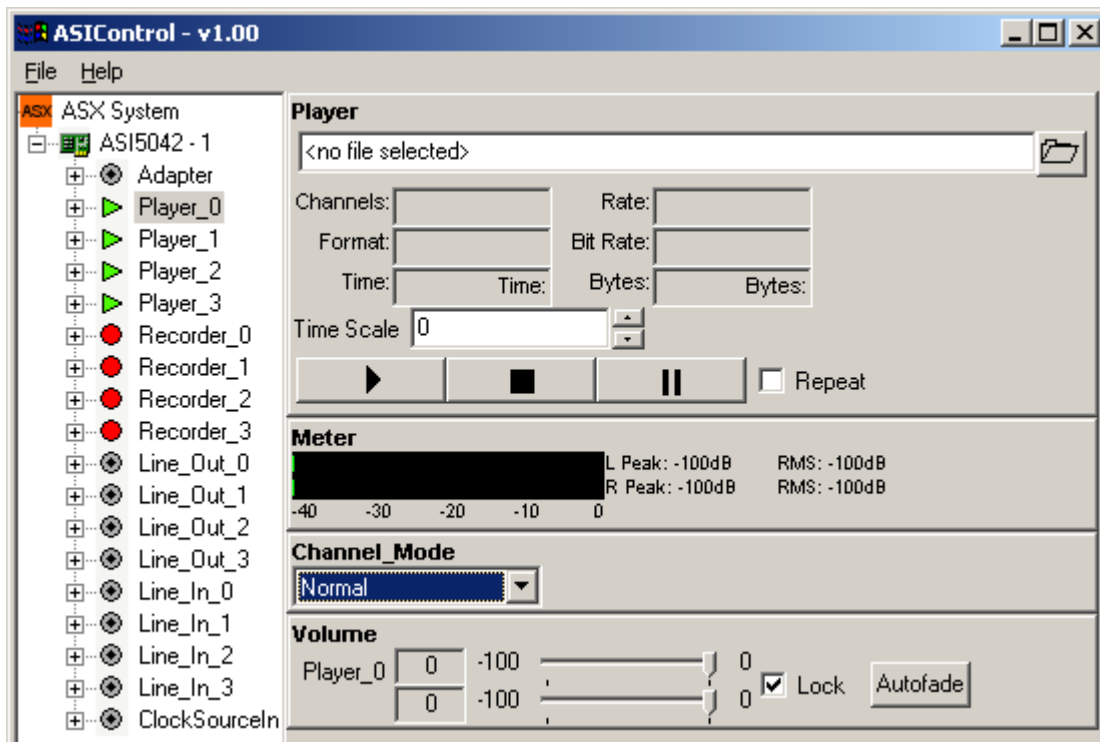

Note the later versions of the driver list the devices starting from 1 not 0

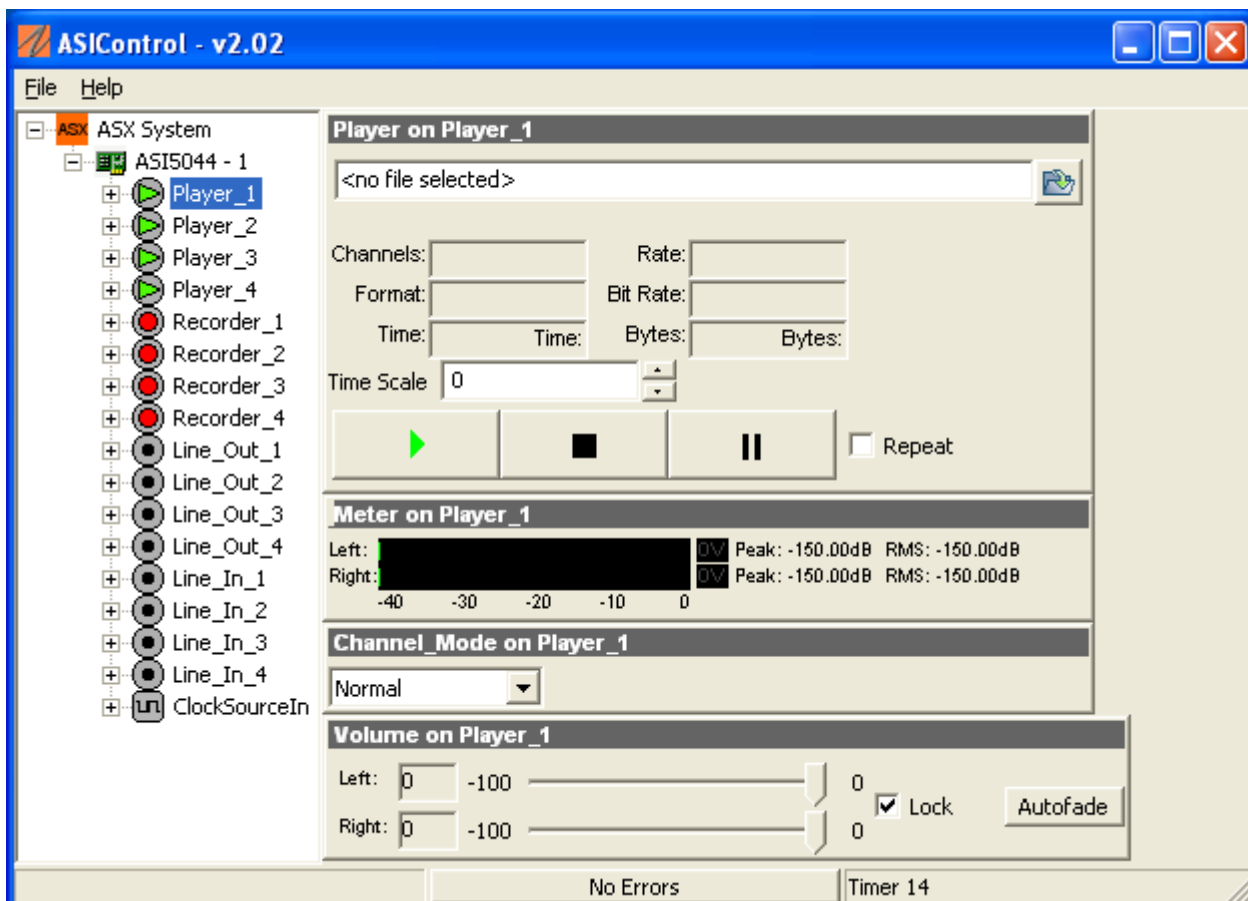

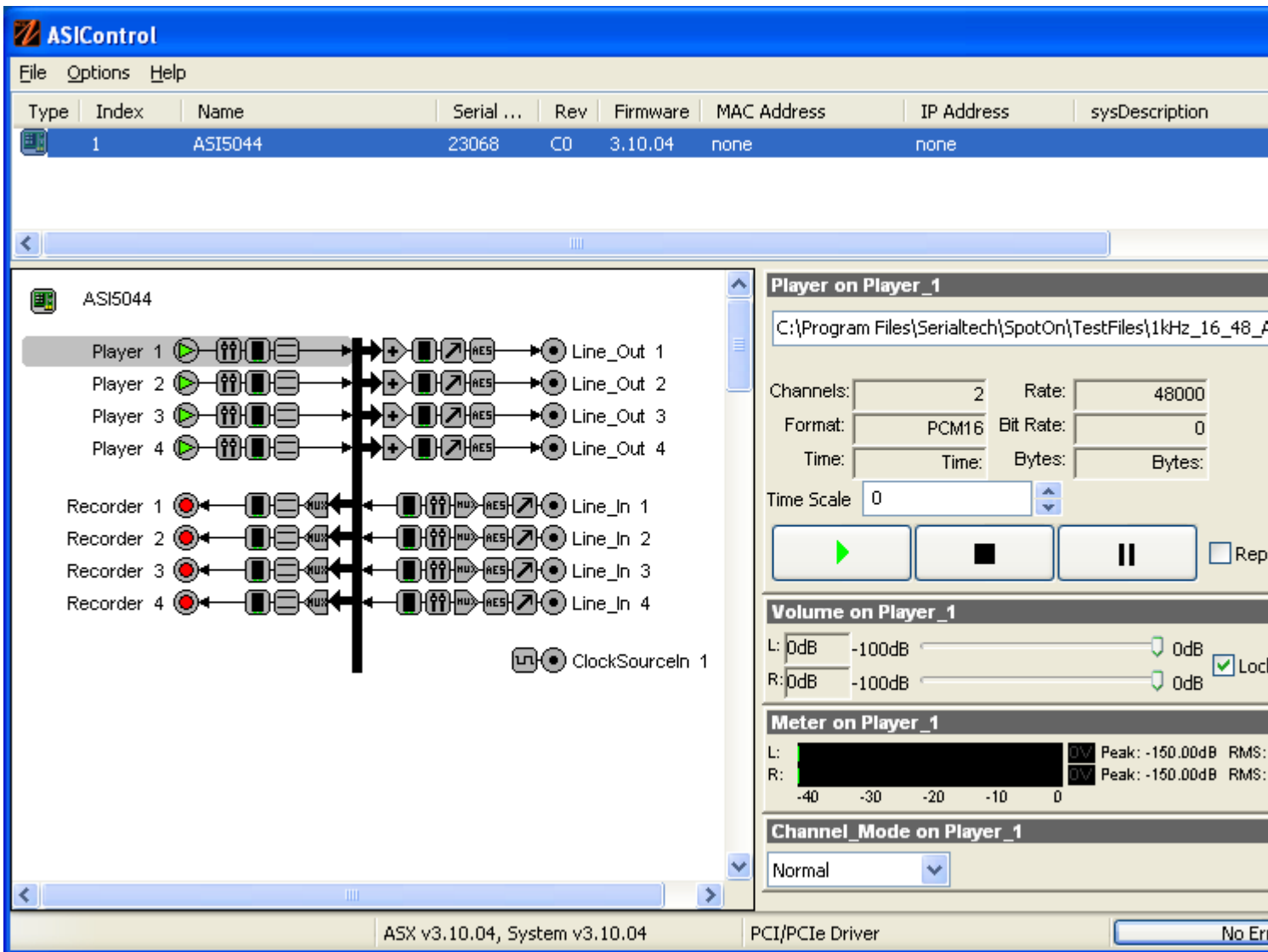

In stereo there are level controls for the four 2 channel outputs:-

Line\_Out\_0, Line\_Out\_1, Line\_Out\_2, LineOut\_3

The audio routed to these outputs is a mix of the input and the four player streams, for use with SpotOn both the volume slider for Player\_0 should be set to maximum on Line\_Out\_0 with sliders for Player\_1, Player\_2, Player\_3 set to zero.

Similarly for:-

Line\_Out\_1 ... Player\_1 slider should be at maximum and sliders for Player\_0, Player\_2, Player\_3 at zero

Line\_Out\_2 ... Player\_2 slider should be at maximum and sliders for Player\_0, Player\_1, Player\_3 at zero

Line\_Out\_3 ... Player\_3 slider should be at maximum and sliders for Player\_0, Player\_1, Player\_2 at zero

The settings for Line\_Out\_0 are shown below.

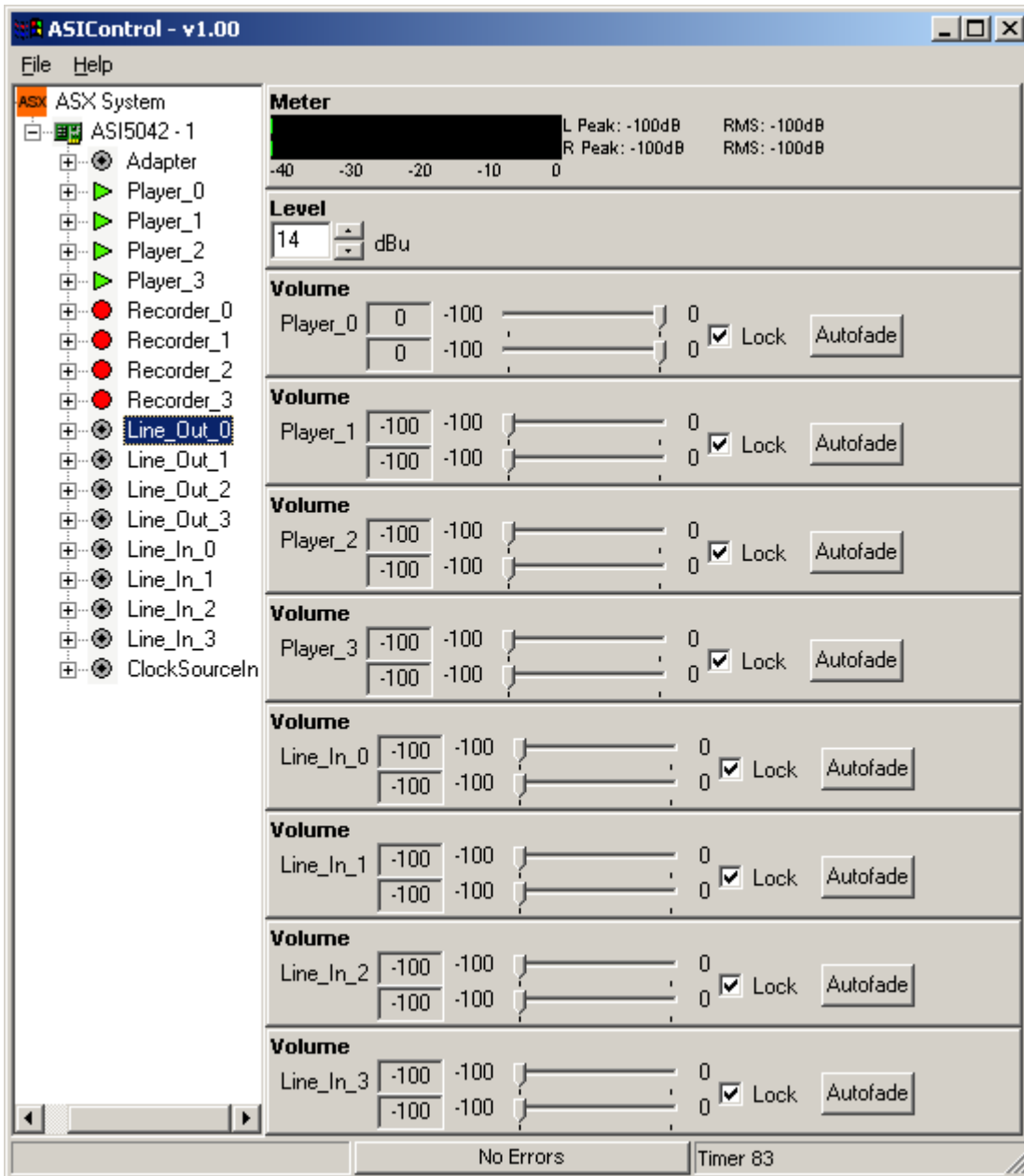

Note the later versions of the driver list the devices starting from 1 not 0

**ASXControl - v2.02** [Min] [Max] [Close]

File Help

ASX System

- ASIS044 - 1
  - Player\_1
  - Player\_2
  - Player\_3
  - Player\_4
  - Recorder\_1
  - Recorder\_2
  - Recorder\_3
  - Recorder\_4
  - Line\_Out\_1**
  - Line\_Out\_2
  - Line\_Out\_3
  - Line\_Out\_4
  - Line\_In\_1
  - Line\_In\_2
  - Line\_In\_3
  - Line\_In\_4
  - ClockSourceIn

**Meter on Line\_Out\_1**

Left: 0V Peak: -150.00dB RMS: -150.00dB  
Right: 0V Peak: -150.00dB RMS: -150.00dB

-40 -30 -20 -10 0

**Level on Line\_Out\_1**

20 dBu

**AESEBU Transmitter on Line\_Out\_1**

AES/EBU Format

AES/EBU  S/PDIF

**Volume on Player\_1 to Line\_Out\_1**

Left: 0 -100 0  Lock Autofade  
Right: 0 -100 0

**Volume on Player\_2 to Line\_Out\_1**

Left: -100 -100 0  Lock Autofade  
Right: -100 -100 0

**Volume on Player\_3 to Line\_Out\_1**

Left: -100 -100 0  Lock Autofade  
Right: -100 -100 0

**Volume on Player\_4 to Line\_Out\_1**

Left: -100 -100 0  Lock Autofade  
Right: -100 -100 0

**Volume on Line\_In\_1 to Line\_Out\_1**

Left: -100 -100 0  Lock Autofade  
Right: -100 -100 0

**Volume on Line\_In\_2 to Line\_Out\_1**

Left: -100 -100 0  Lock Autofade  
Right: -100 -100 0

No Errors | Timer 94

**ASISControl** [Window Title]

File Options Help

Type	Index	Name	Serial ...	Rev	Firmware	MAC Address	IP Address	sysDescription	sysName
	1	ASIS044	23068	C0	3.10.04	none	none		

ASIS044

Player 1 → Line\_Out 1  
 Player 2 → Line\_Out 2  
 Player 3 → Line\_Out 3  
 Player 4 → Line\_Out 4

Recorder 1 ← Line\_In 1  
 Recorder 2 ← Line\_In 2  
 Recorder 3 ← Line\_In 3  
 Recorder 4 ← Line\_In 4

ClockSourceIn 1

**Volume on Player\_1 to Line\_Out\_1**

L: 0dB -100dB [Slider] 0dB  Lock Fade  
 R: 0dB -100dB [Slider] 0dB  Lock Fade

**Volume on Player\_2 to Line\_Out\_1**

L: -100dB -100dB [Slider] 0dB  Lock Fade  
 R: -100dB -100dB [Slider] 0dB  Lock Fade

**Volume on Player\_3 to Line\_Out\_1**

L: -100dB -100dB [Slider] 0dB  Lock Fade  
 R: -100dB -100dB [Slider] 0dB  Lock Fade

**Volume on Player\_4 to Line\_Out\_1**

L: -100dB -100dB [Slider] 0dB  Lock Fade  
 R: -100dB -100dB [Slider] 0dB  Lock Fade

**Volume on Line\_In\_1 to Line\_Out\_1**

L: -100dB -100dB [Slider] 0dB  Lock Fade  
 R: -100dB -100dB [Slider] 0dB  Lock Fade

**Volume on Line\_In\_2 to Line\_Out\_1**

L: -100dB -100dB [Slider] 0dB  Lock Fade  
 R: -100dB -100dB [Slider] 0dB  Lock Fade

ASX v3.10.04, System v3.10.04      PCI/PCIe Driver      No Errors

## DigiGram VX422



The DigiGram VX422 sound card is a 6 output card and is configured with 3 x 2 channel o/ps, these outputs are referred to as WavOut 1/2, WavOut 3/4 and WavOut AES.

The card is setup via a utility provided by the manufacturers and comprises a main window with five tabbed pages as shown below.

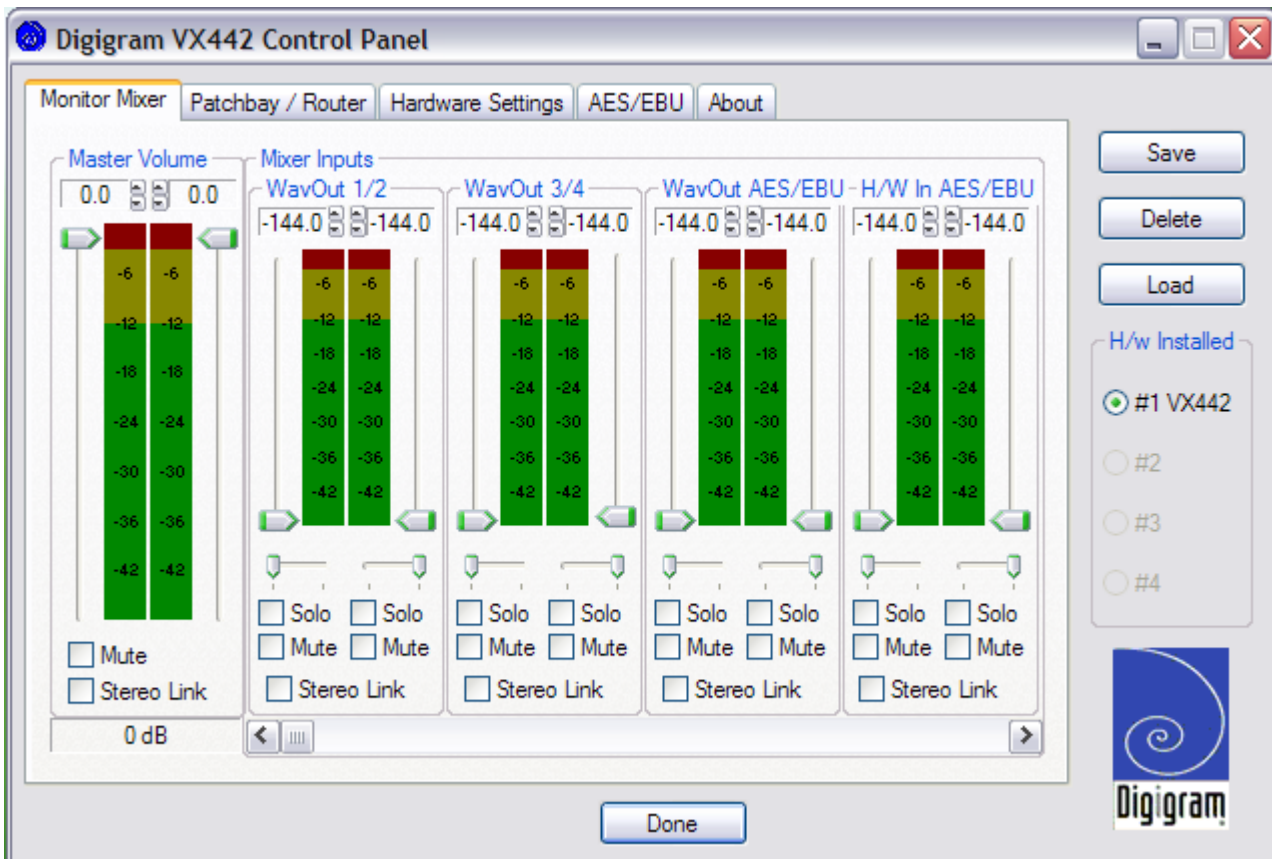

The first tab - Monitor Mixer - sets the contributions of the various output signals into a separate monitor mix, initially it is suggested that this is not used until the system is up and fully working, therefore the settings should be as shown above.

The second tab - Patchbay/Router - allows each hardware output pair to be itself a combination of various inputs, for simplicity the patching should be simple where only WavOut 1/2 is patched to H/W out 1/2 and WavOut 3/4 is patched to H/W out 3/4 etc.

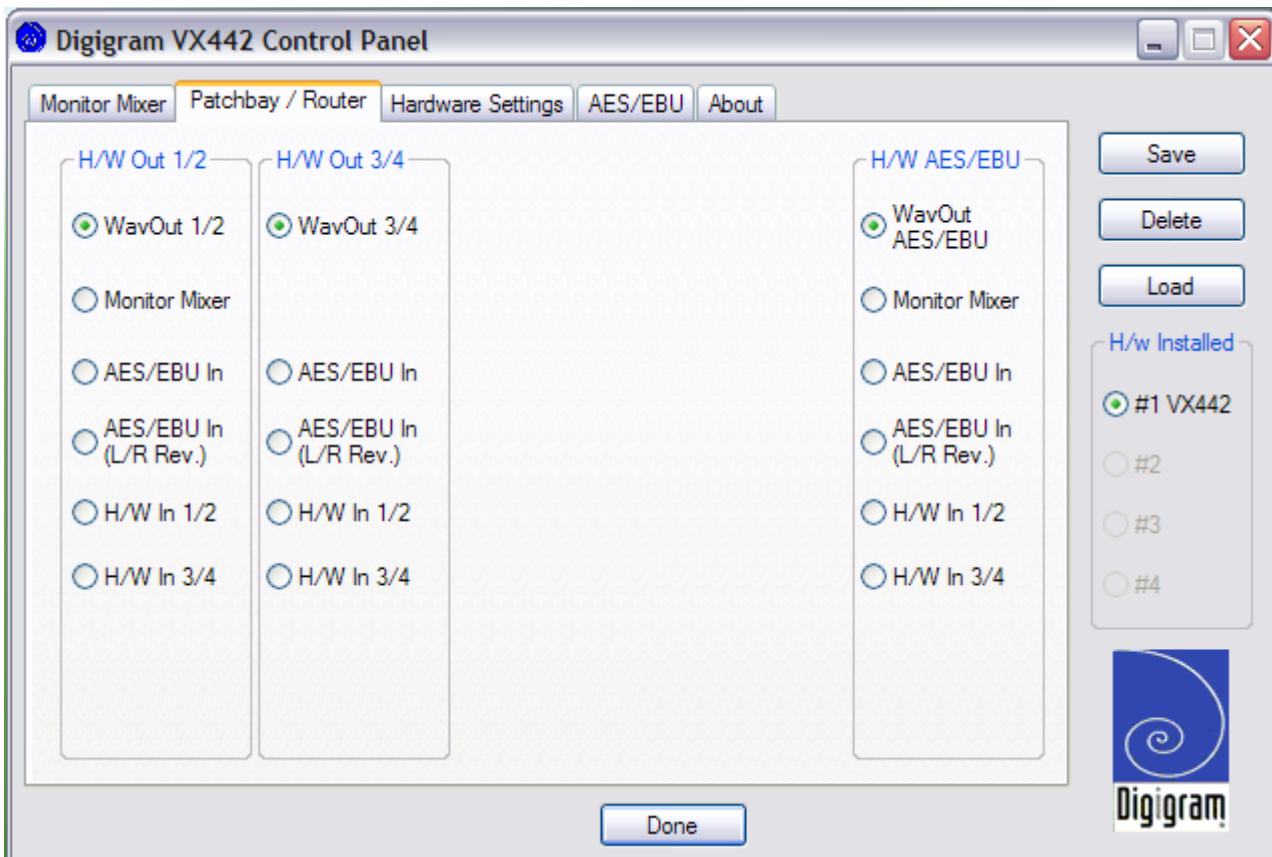

The sample rate and reference settings are made in the third tab, this is the tab where most mistakes are made so it is important to check the following items:-

Master Clock = Internal Xtal

Codec Sample Rate = 44,100 or 48,000 as suits the installation with the 'Rate Locked' option checked

MultiTrack Driver Devices = Independent

DMA Buffer Size (latency) = 1024

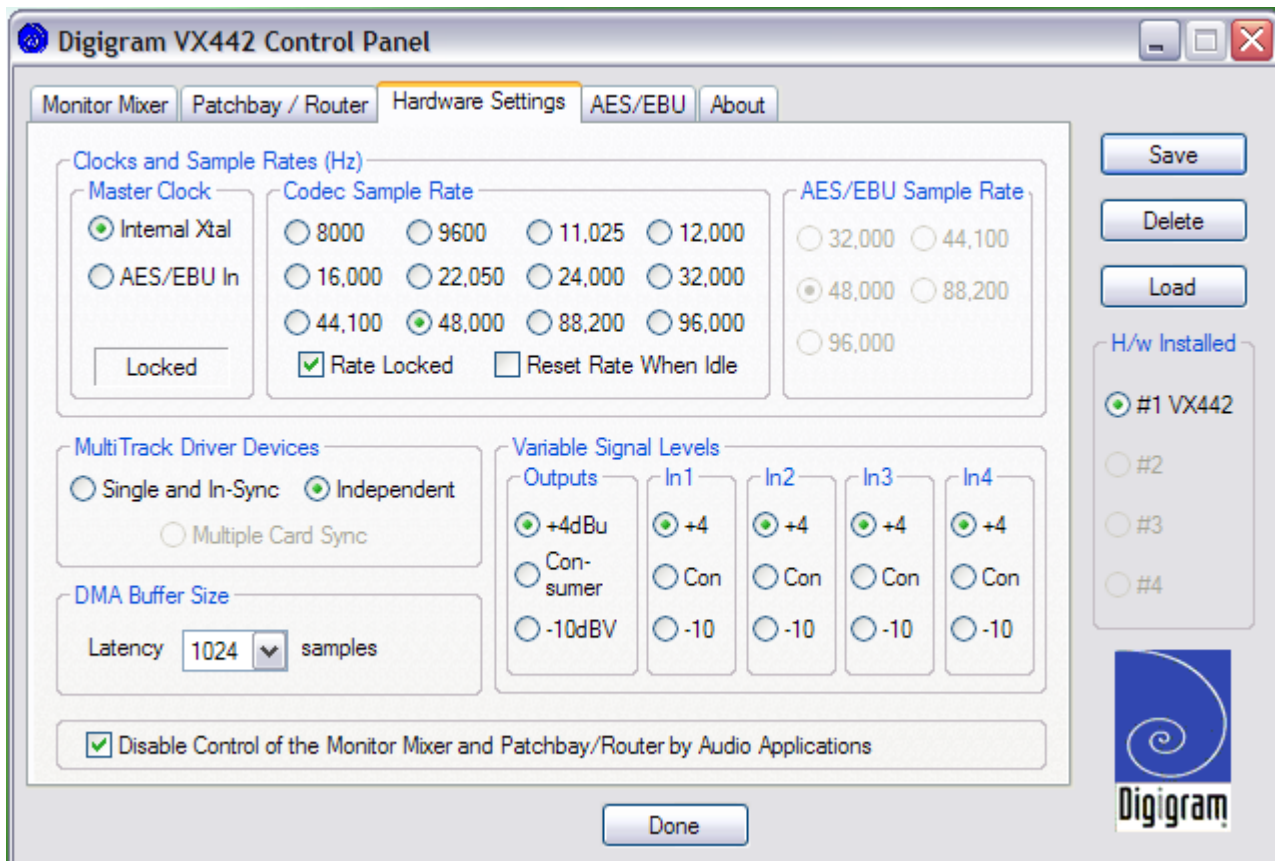

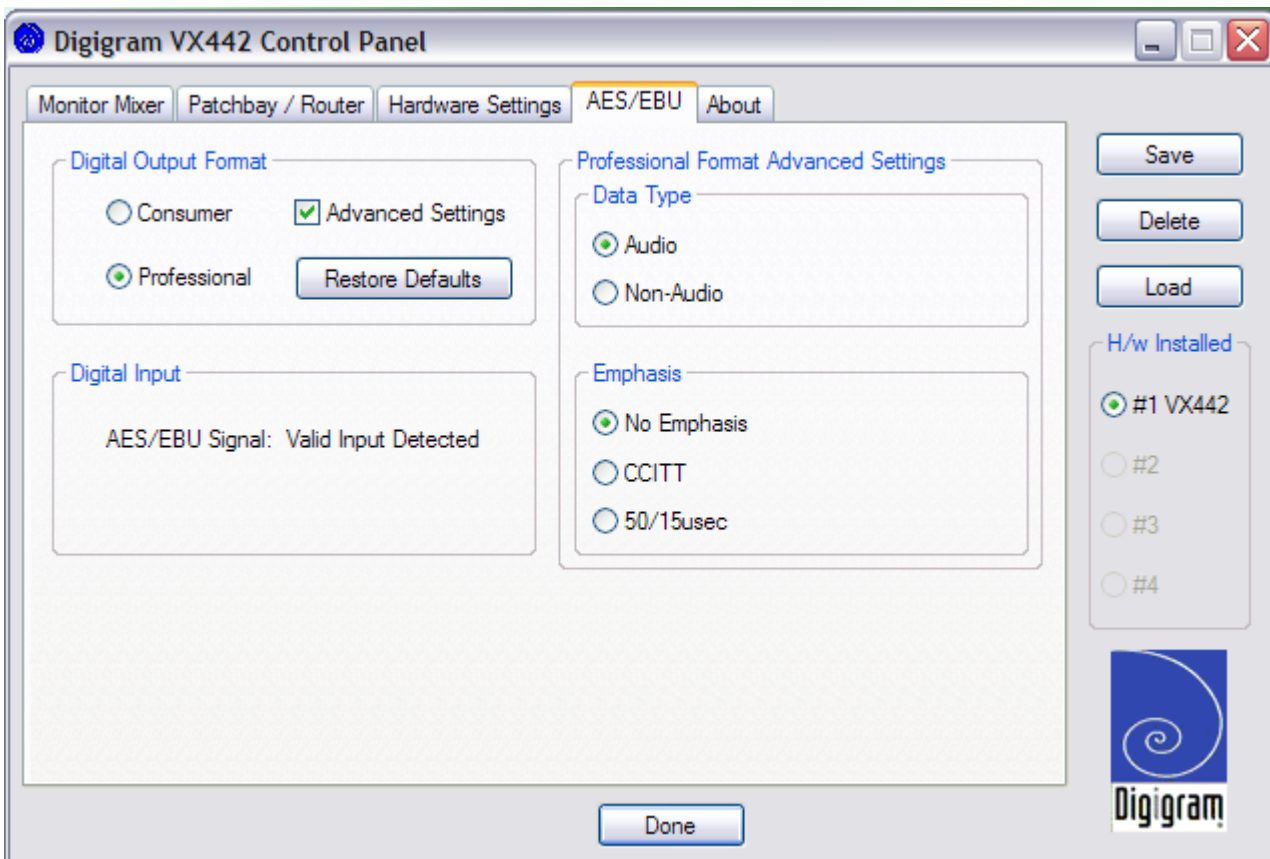

The final tab is the DigiGram About screen

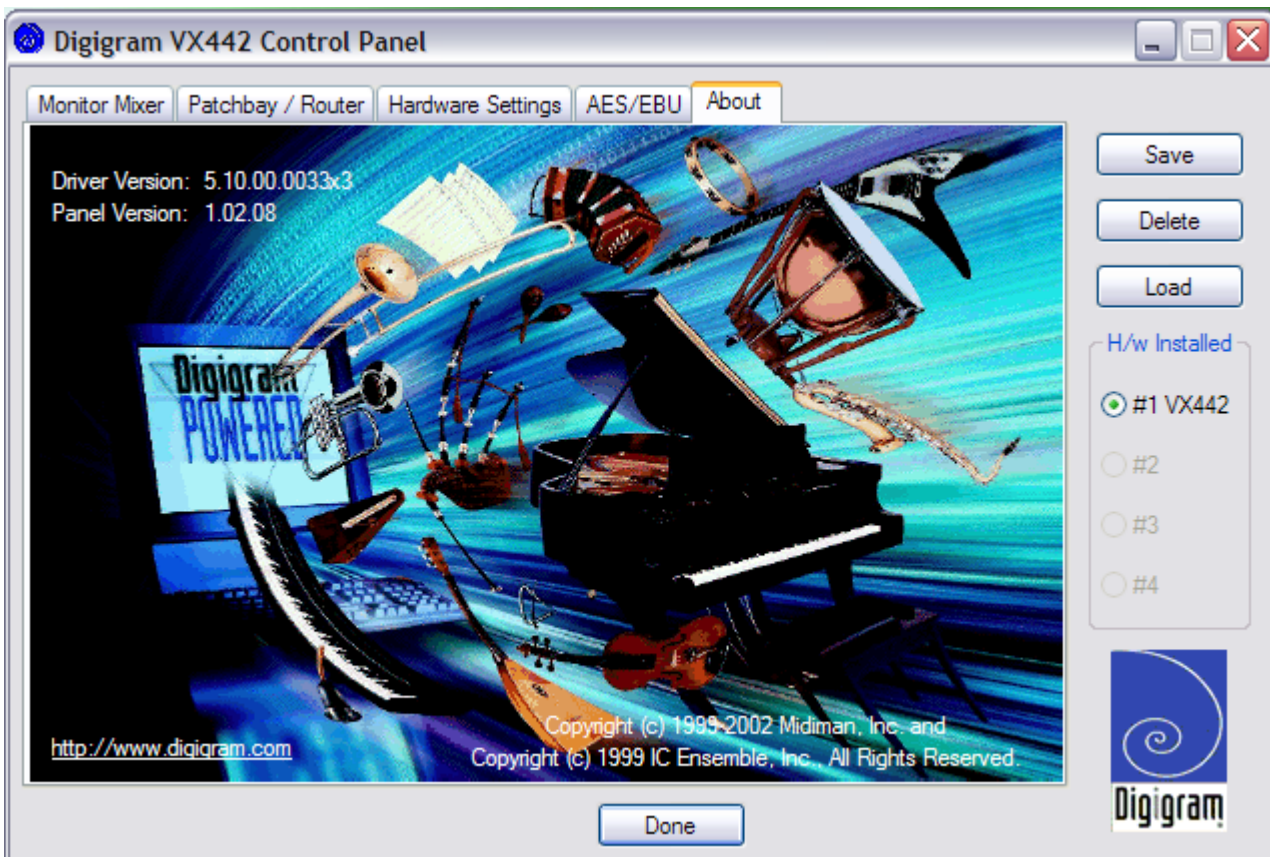

The card presents itself to SpotOn as 4 entries in the Output Devices list in the case below appearing as o/p/s A..D:-

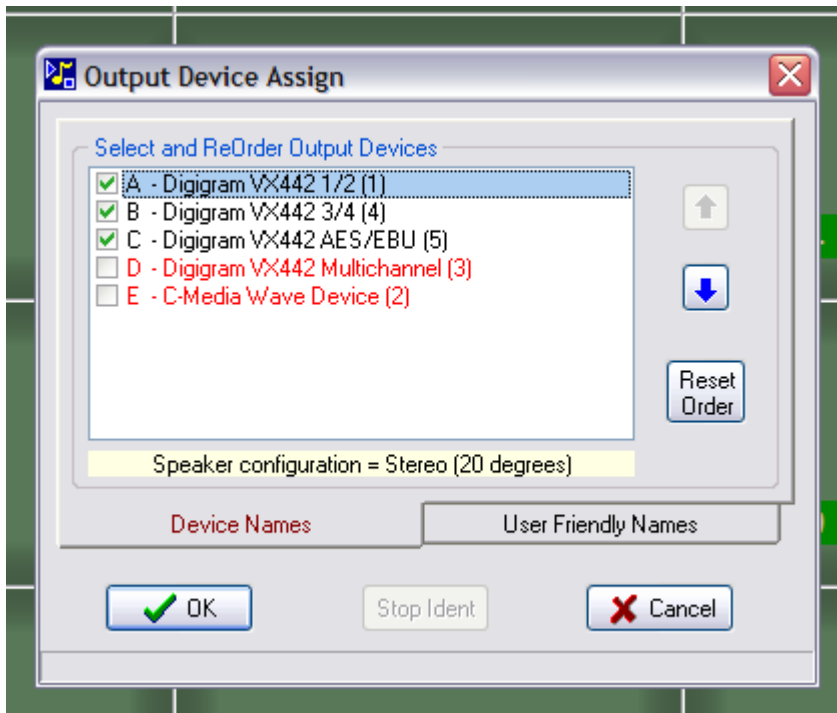

Only the first three outputs are required so o/p/s D and E have been masked out and are shown in red text.

## Gina 3G



The Echo Gina 3G sound card is an 6 output card and is configured with 3 x 2 channel o/ps, these outputs are referred to as Analog out 1-2, Analog out 3-4 and Analog out 5-6

The card is setup via a utility provided by the manufacturers and comprises a main window as shown below.

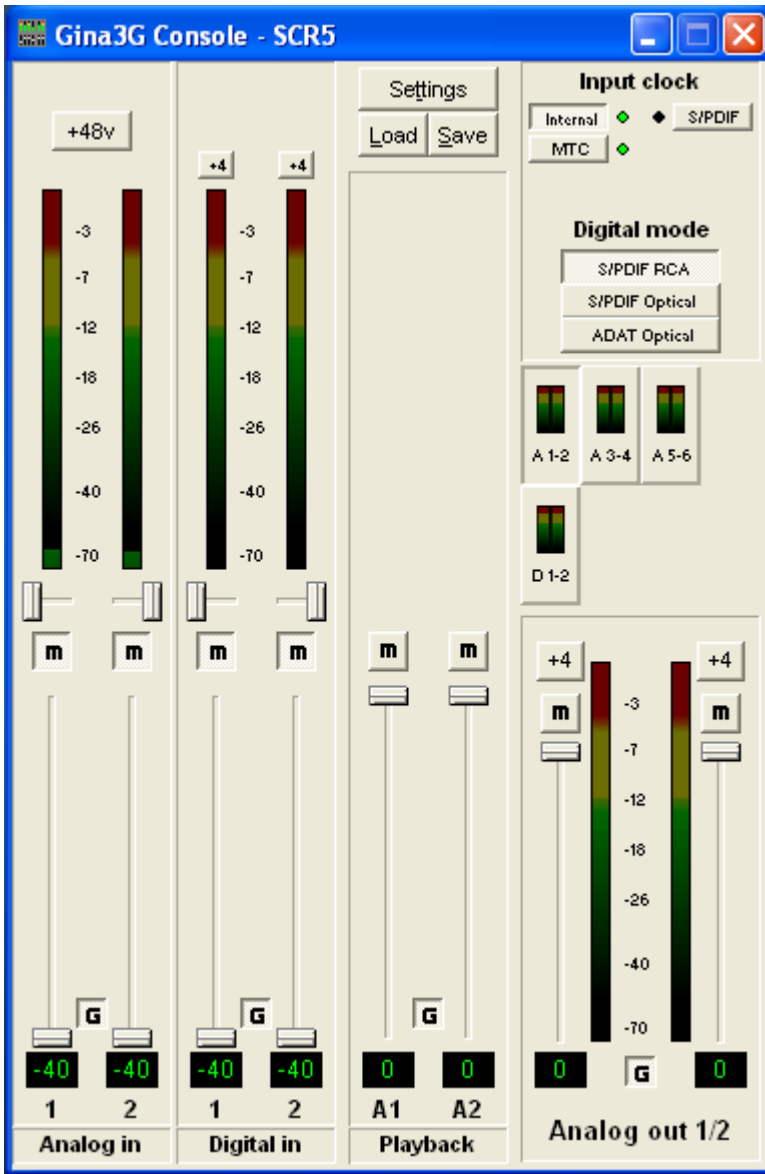

For normal use the faders and options should be as indicated above.

More detailed configuration options are available via the "Settings" button, this brings up a dialog box with 6 tabs.

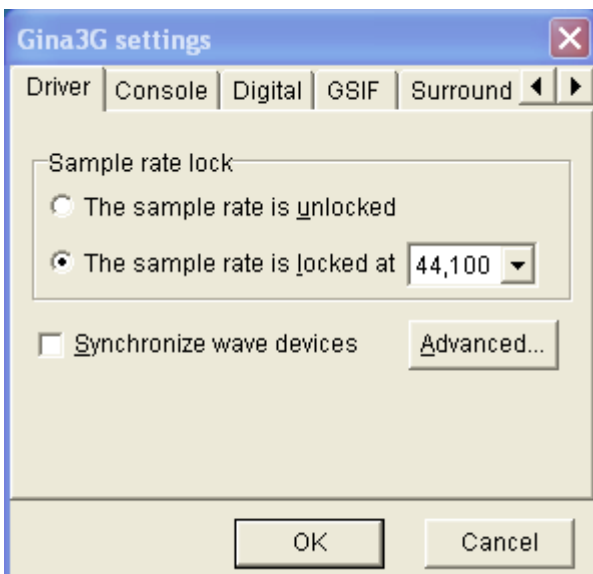

Clicking on Advanced shows the output device mapping dialog, with the default of 3 stereo outputs.

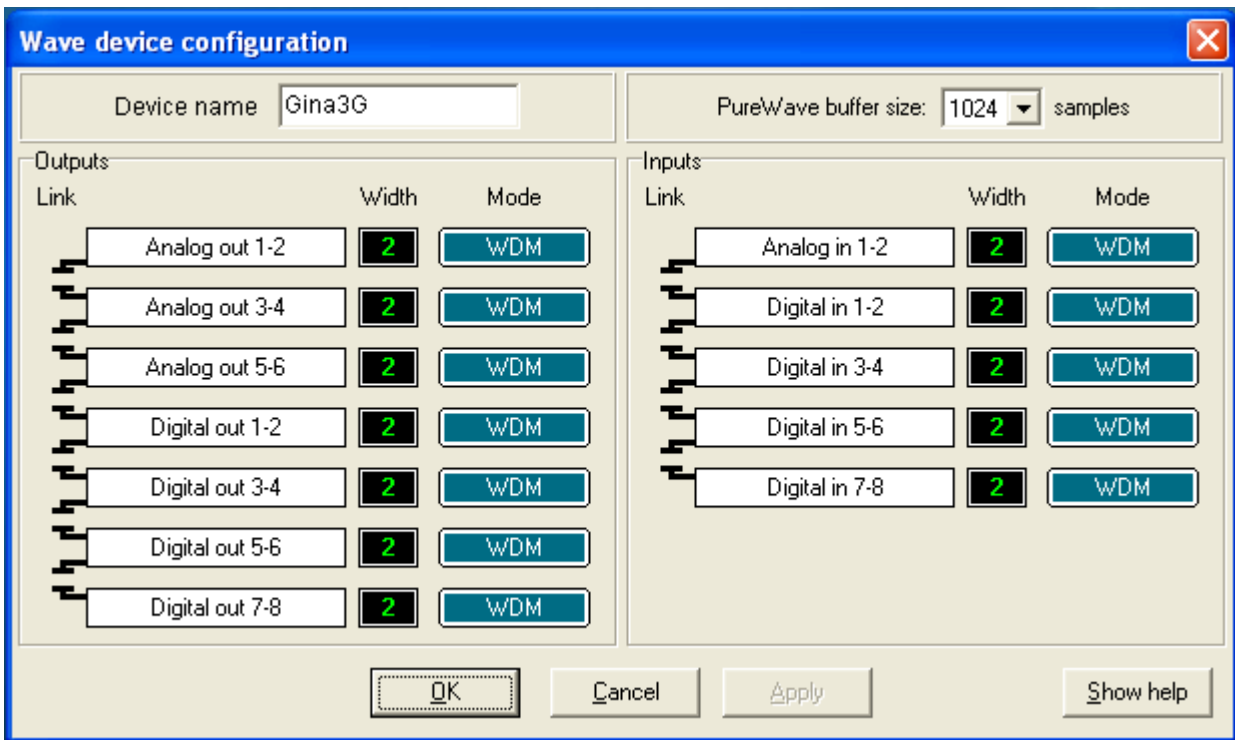

For multichannel work the card can be used as 1 x 6 channel (5.1) as shown below, the channels are combined by clicking between the two horizontal bars to the left of the white boxes

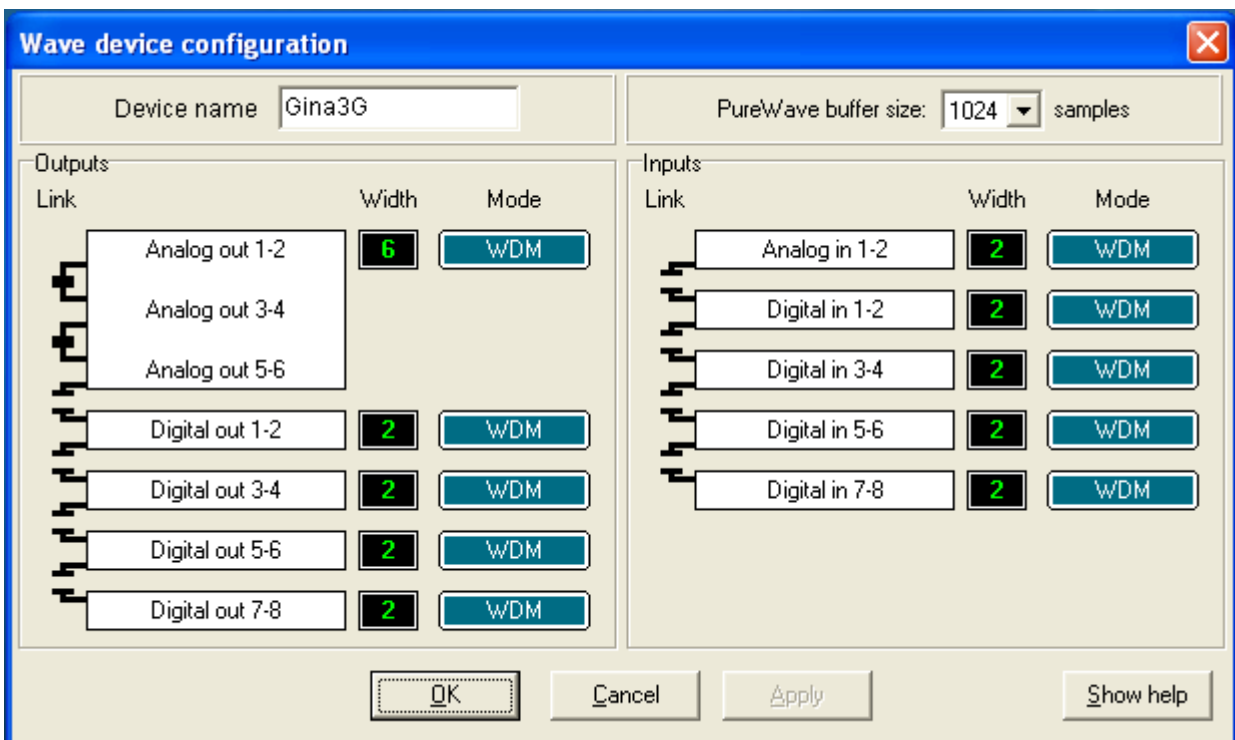

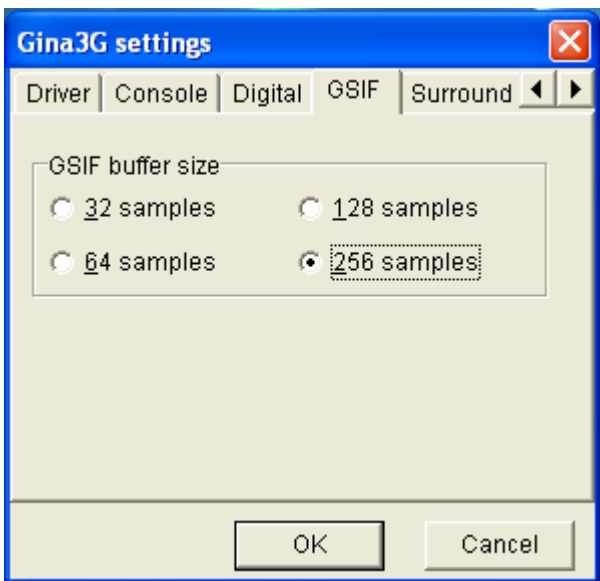
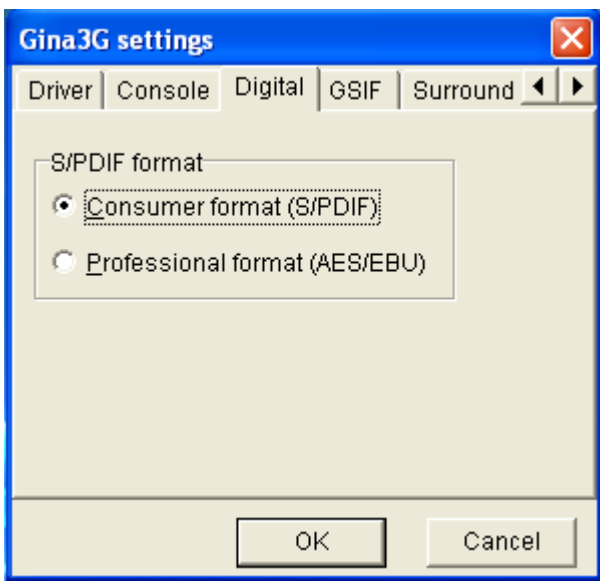
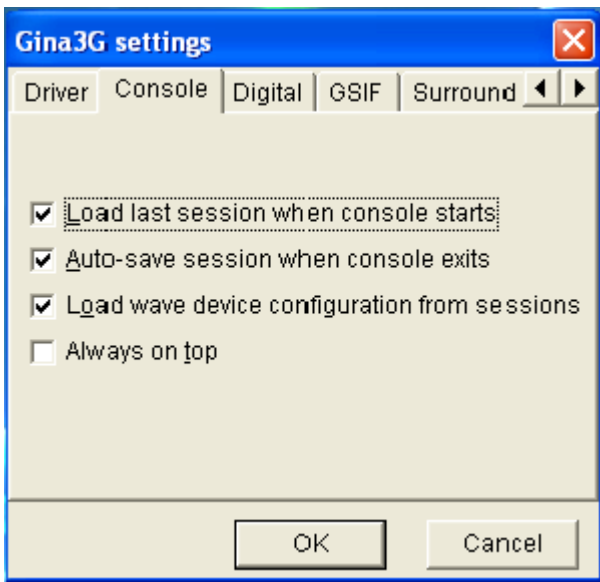

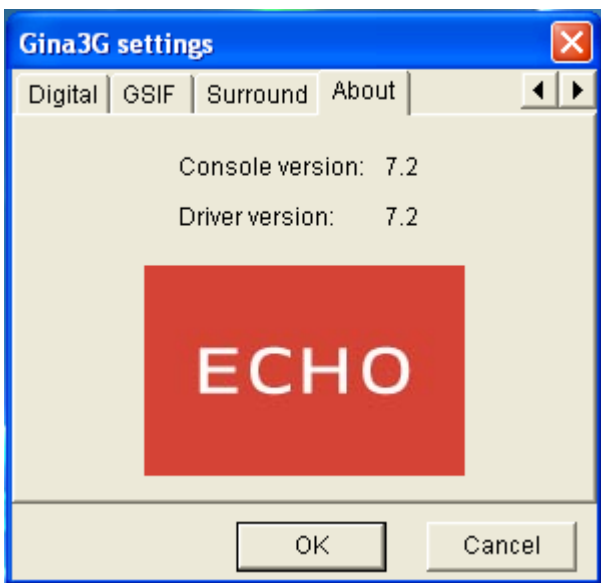
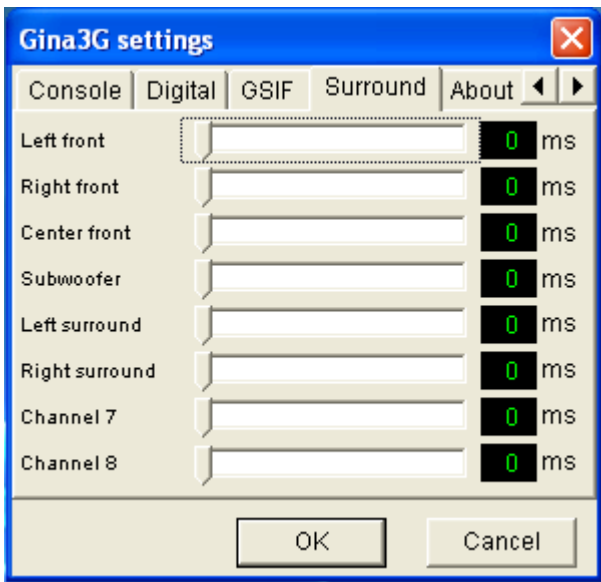

The card presents itself to SpotOn as 6 analogue entries in the Output Devices list in the case below appearing as o/p/s A, B and C:-

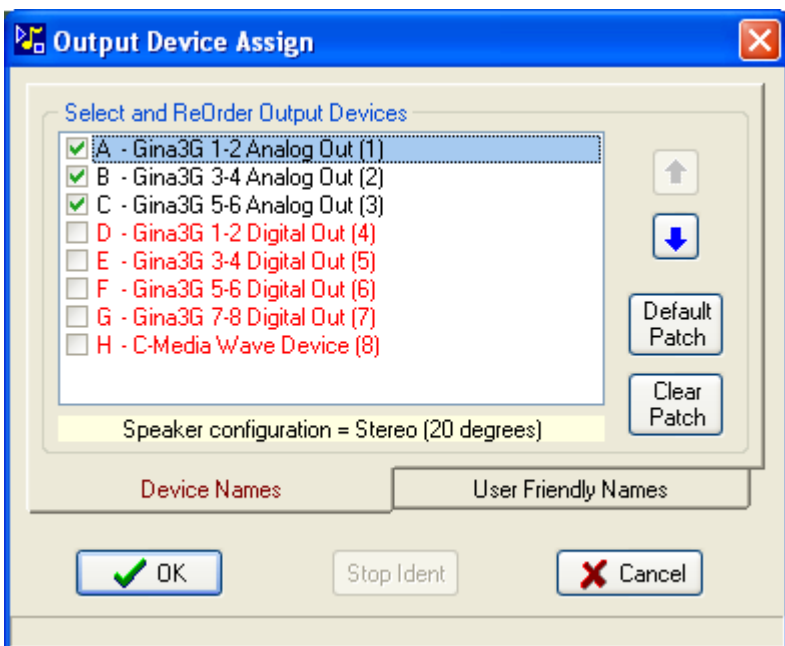

# Layla3G



The Echo Layla 3G sound card is an 8 output card and is configured with 4 x 2 channel o/ps, these outputs are referred to as Analog out 1-2, Analog out 3-4, Analog out 5-6 and Analog out 7-8.

The card is setup via a utility provided by the manufacturers and comprises a main window as shown below.



For normal use the faders and options should be as indicated above.

More detailed configuration options are available via the "Settings" button, this brings up a dialog box with 5 tabs.

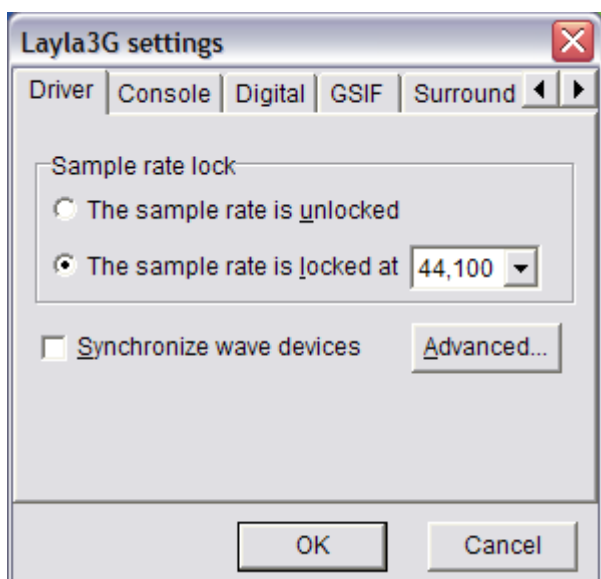

Clicking on Advanced shows the output device mapping dialog, with the default of 4 x stereo outputs.

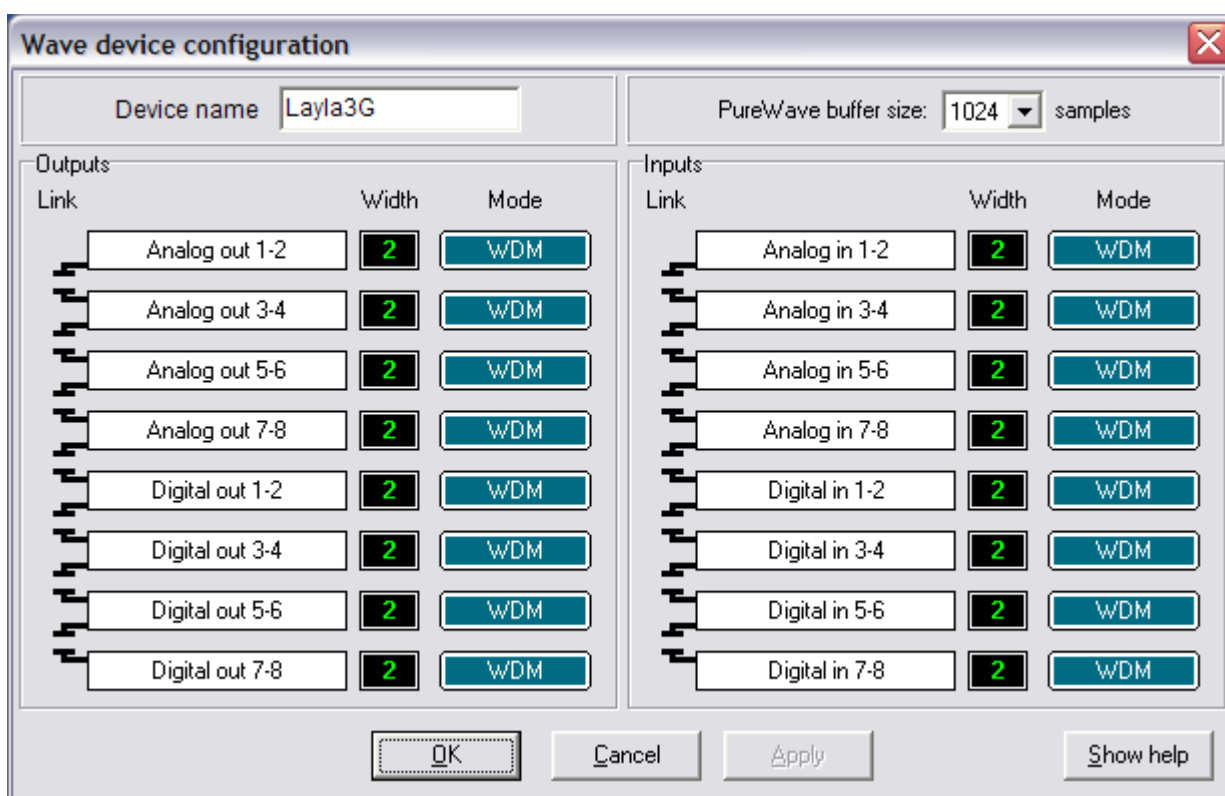

For multichannel work the card can be used as 1 x 6 channel (5.1) + 1 x stereo channel as shown below, the channels are combined by clicking between the two horizontal bars to the left of the white boxes

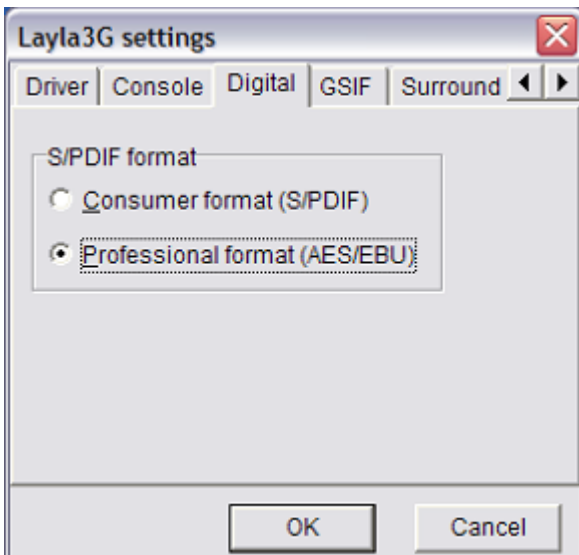
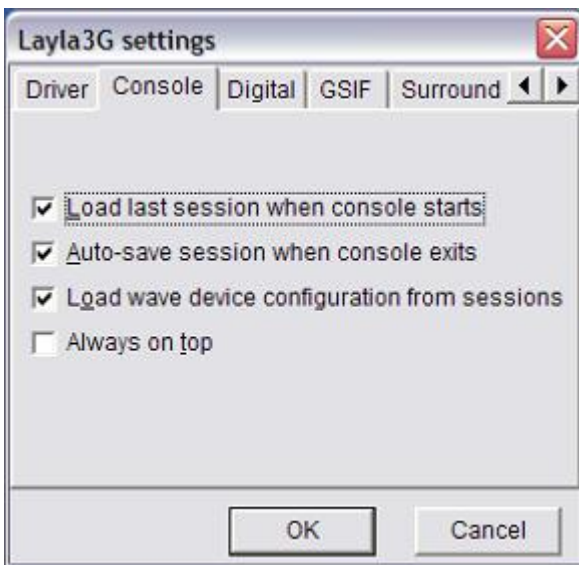
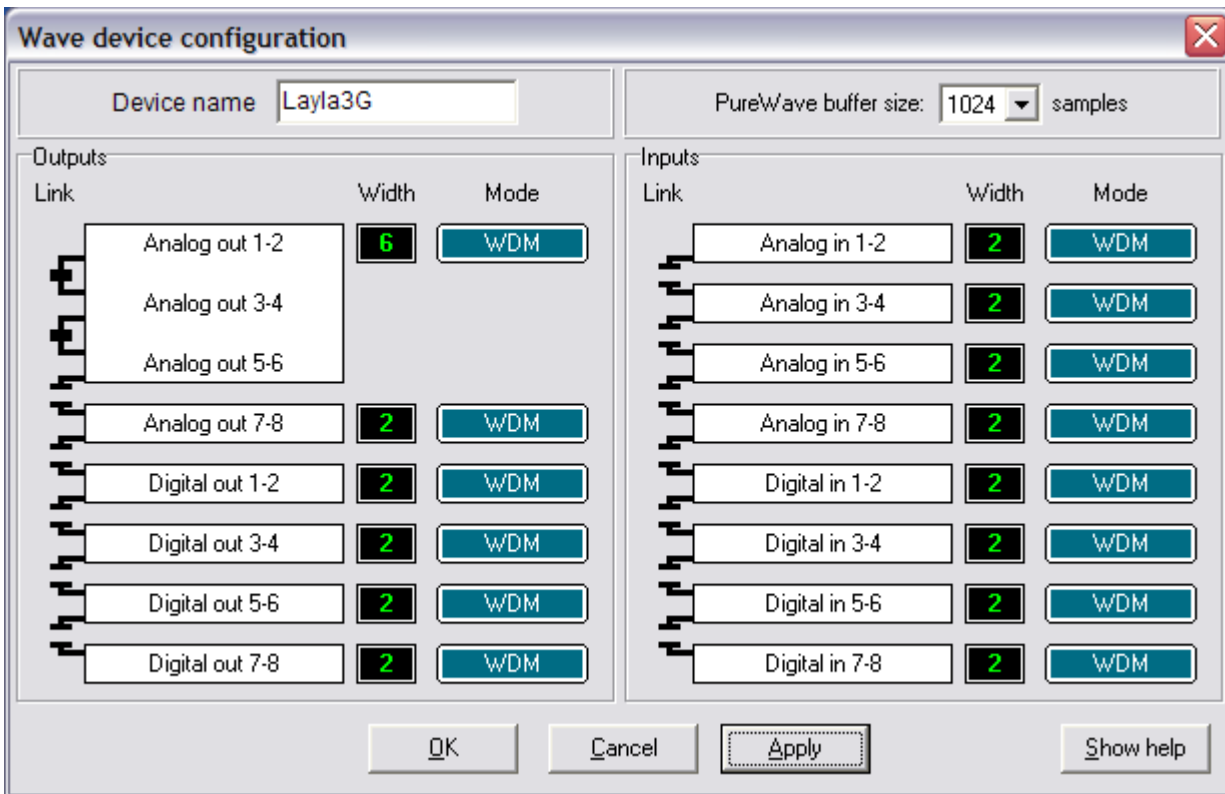

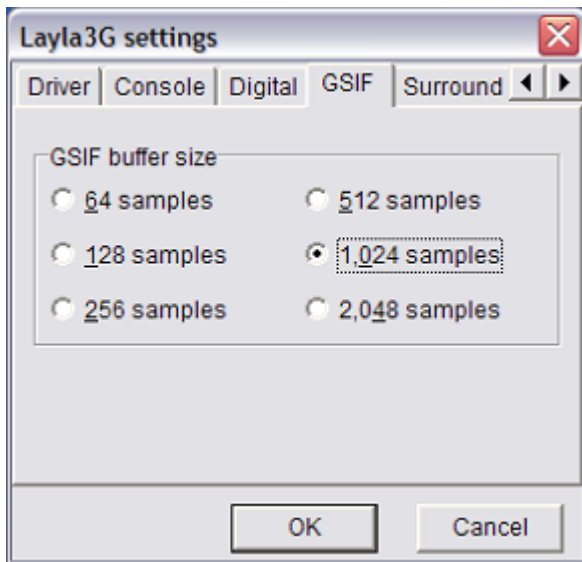

The card presents itself to SpotOn as 8 entries in the Output Devices list in the case below appearing as o/ps A..H:-

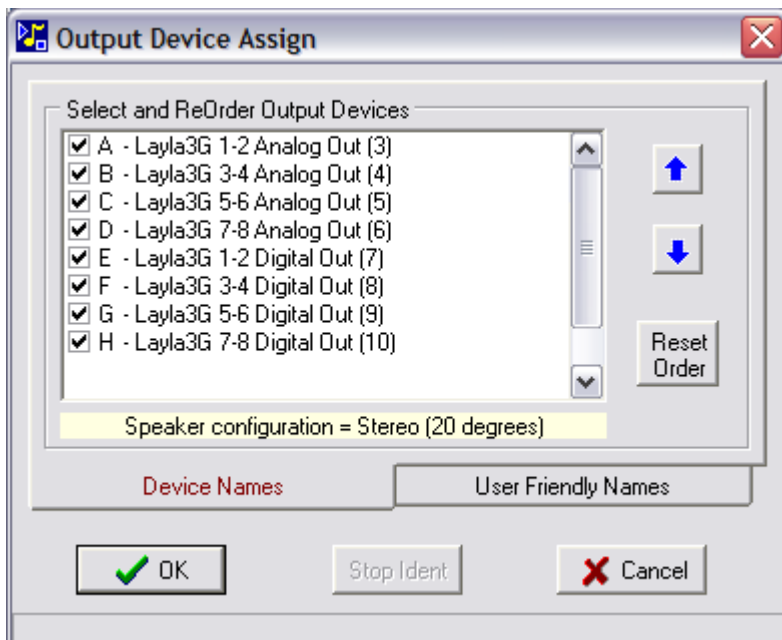

# Edirol UA-101/UA-25

## UA-101



The Edirol UA-101 is a USB 2.0 soundcard with four analogue stereo outputs and a Midi In/Out interface.

Once the driver for the soundcard has been loaded and the computer restarted you can access the UA-101 settings from the icon in Windows Control Panel.



To setup the card first select Driver|Driver Settings.



In the Driver Settings dialog box the only item that should be checked is 'Use Separated Ports', all other items should be left unchecked. This allows Windows to access each individual output, however, this feature is only available when using a USB 2.0 compatible port on your computer.

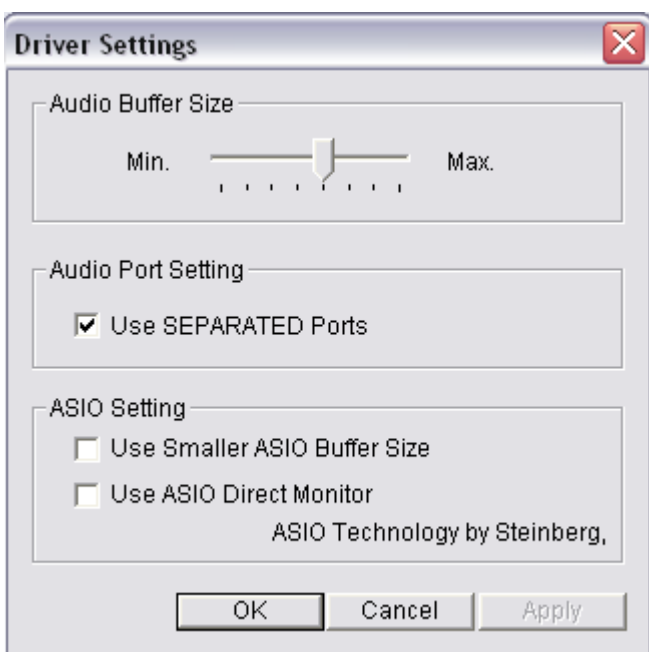

Next go to Device|Set Patch Bay menu



Ensure output patch is set as shown in the picture below, once changes have been made exit out of the UA-101 Control Panel and restart your computer.

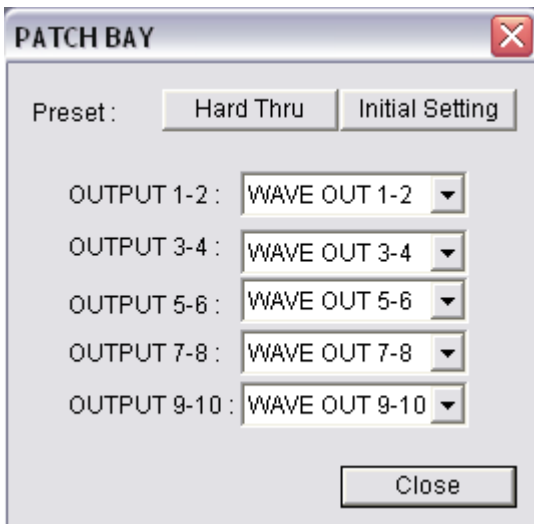

After restarting the computer access the Sounds and Audio Devices Properties icon in the Windows Control Panel.

Set the Sound Playback default device to be 'UA-101 1-2 Separated' .

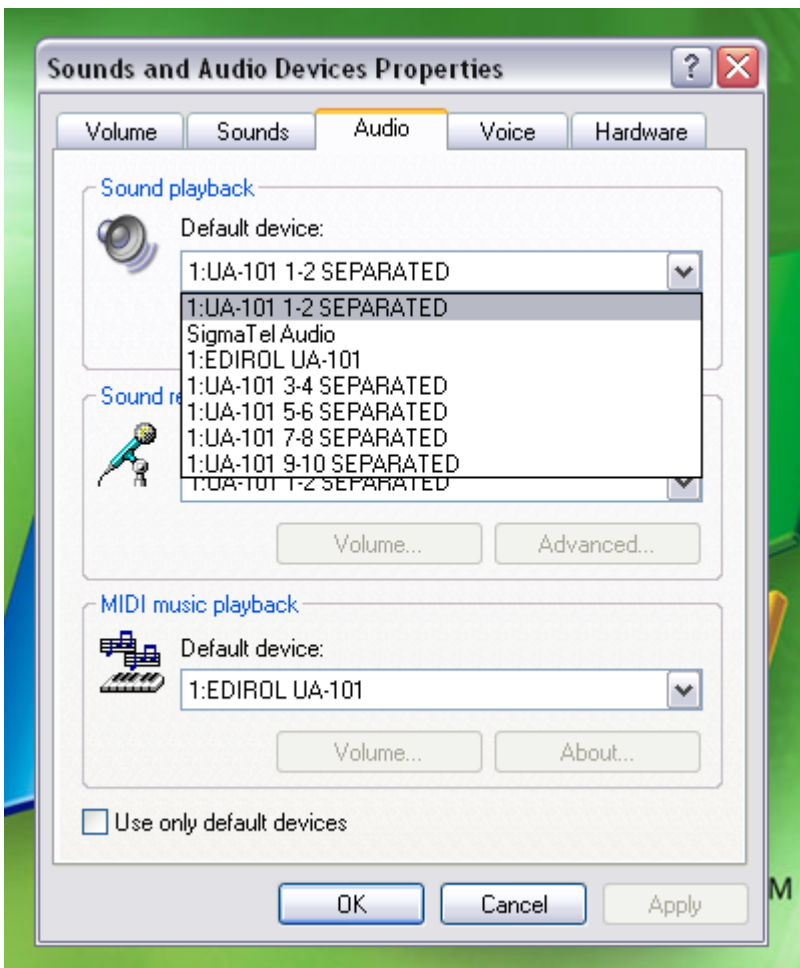

Next run up SpotOn and go to the Admin menu, select the Output Device Assign item where the audio outputs from the UA-101 soundcard can be reordered.

Typical initial order is shown below

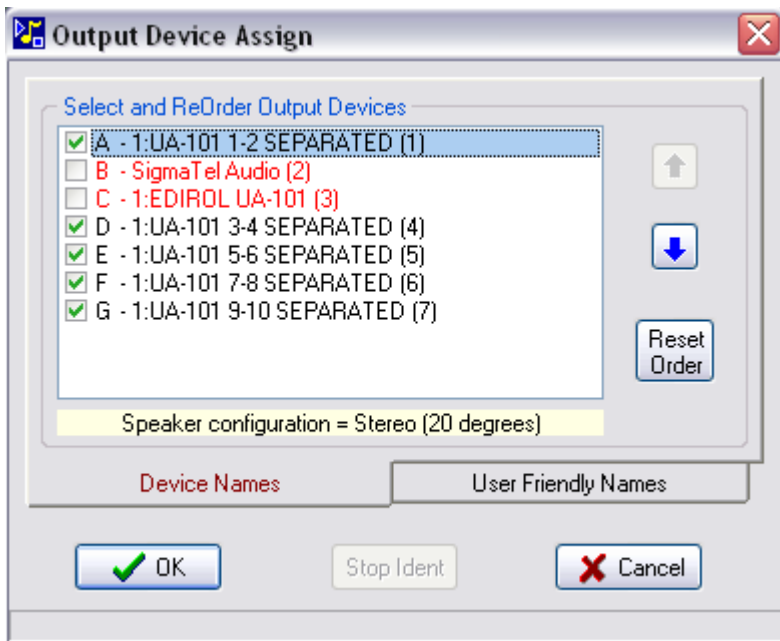

After reordering outputs

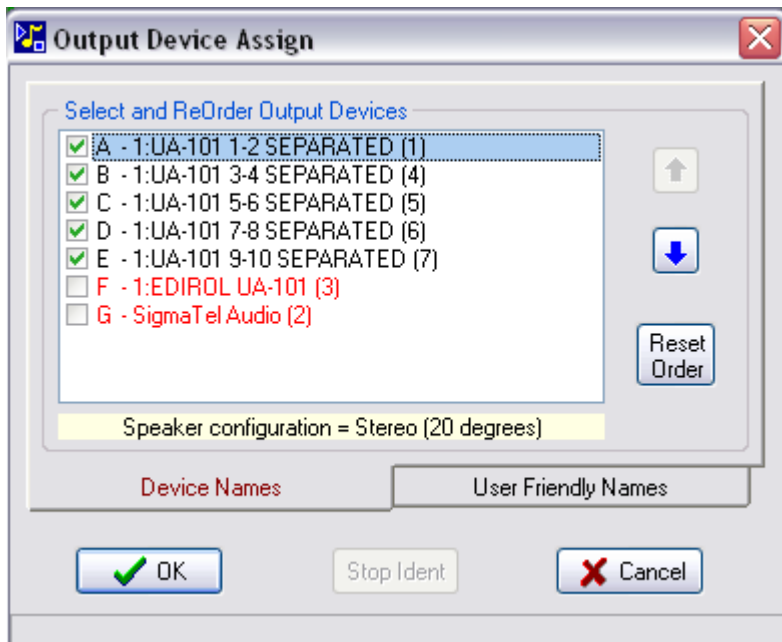

Note that after reordering the outputs, SpotOn will need to be restarted before the changes take effect.

It is recommended that the UA-101 soundcard is always plugged into the same USB 2.0 socket each time it is used, otherwise Windows will treat it as a new device and the output order assignment in SpotOn may well change.

Similarly, if the computer is started up without the UA-101 connected it may be necessary to re-assign the audio output device order next time SpotOn is used.

# UA-25

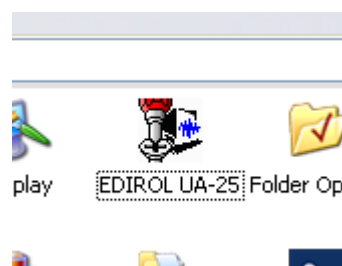

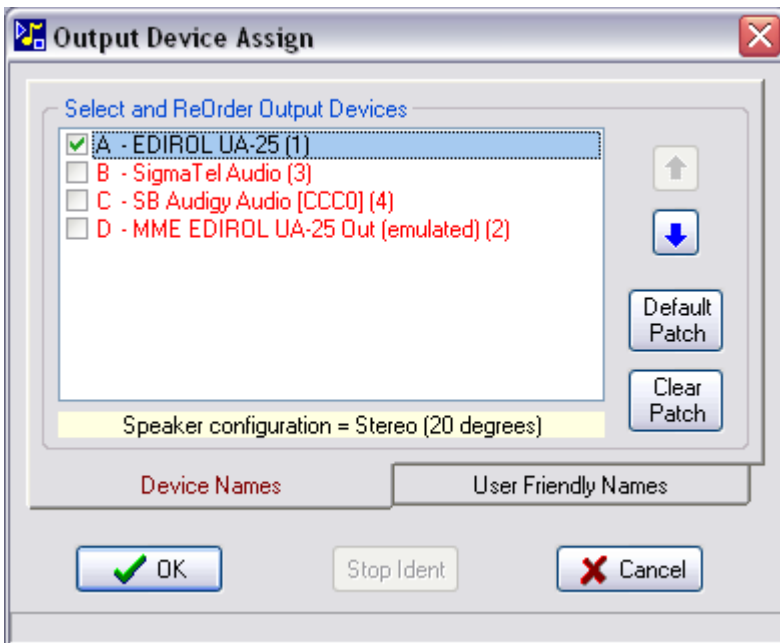

# M-Audio Delta 1010



The M-Audio 1010 sound card is an 8 output card and is configured with 4 x 2 channel o/p/s, these outputs are referred to as WavOut 1/2, WavOut 3/4, WavOut 5/6 and WavOut 7/8.

The card is setup via a utility provided by the manufacturers and comprises a main window with five tabbed pages as shown below.

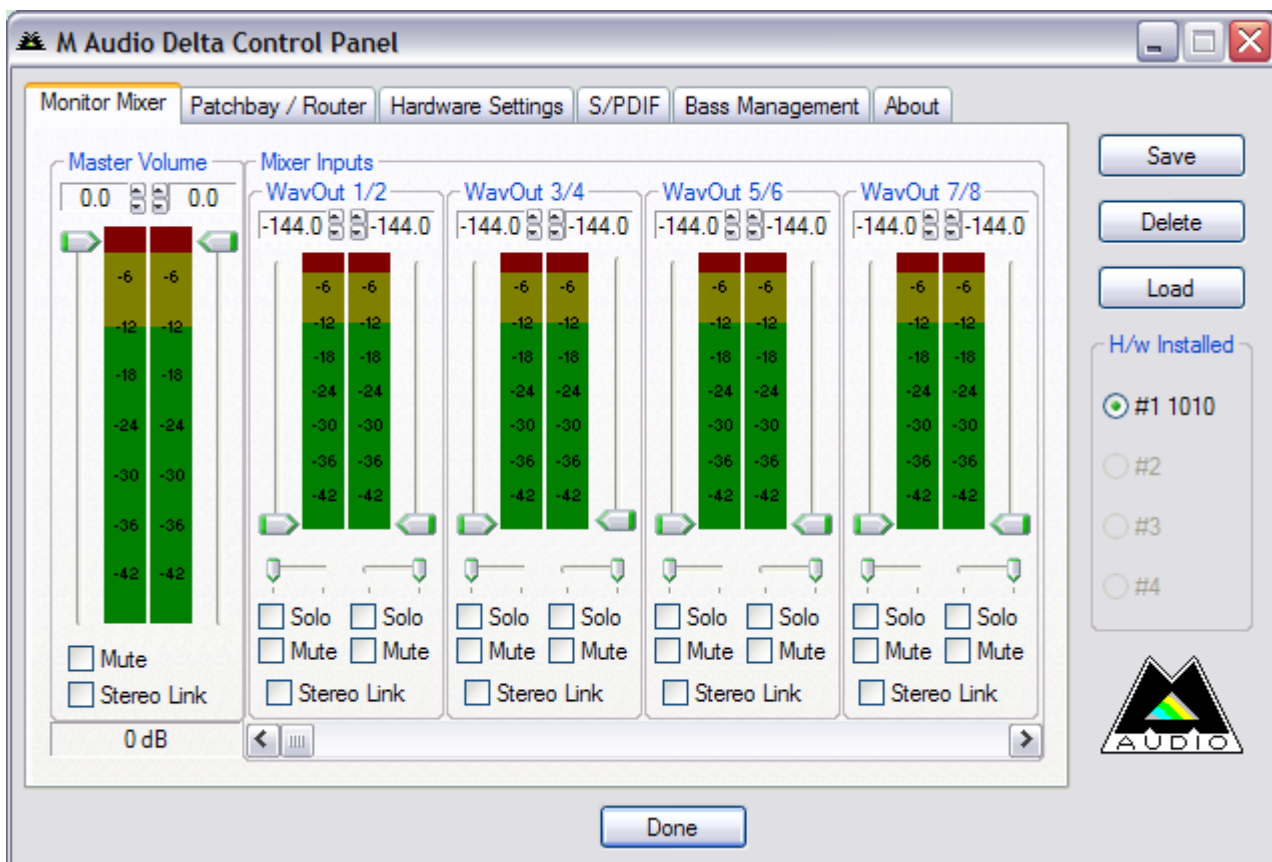

The first tab - Monitor Mixer - sets the contributions of the various output signals into a separate monitor mix, initially it is suggested that this is not used until the system is up and fully working, therefore the settings should be as shown above.

The second tab - Patchbay/Router - allows each hardware output pair to be itself a combination of various inputs, for simplicity the patching should be simple where only WavOut 1/2 is patched to H/W out 1/2 and WavOut 3/4 is patched to H/W out 3/4 etc.

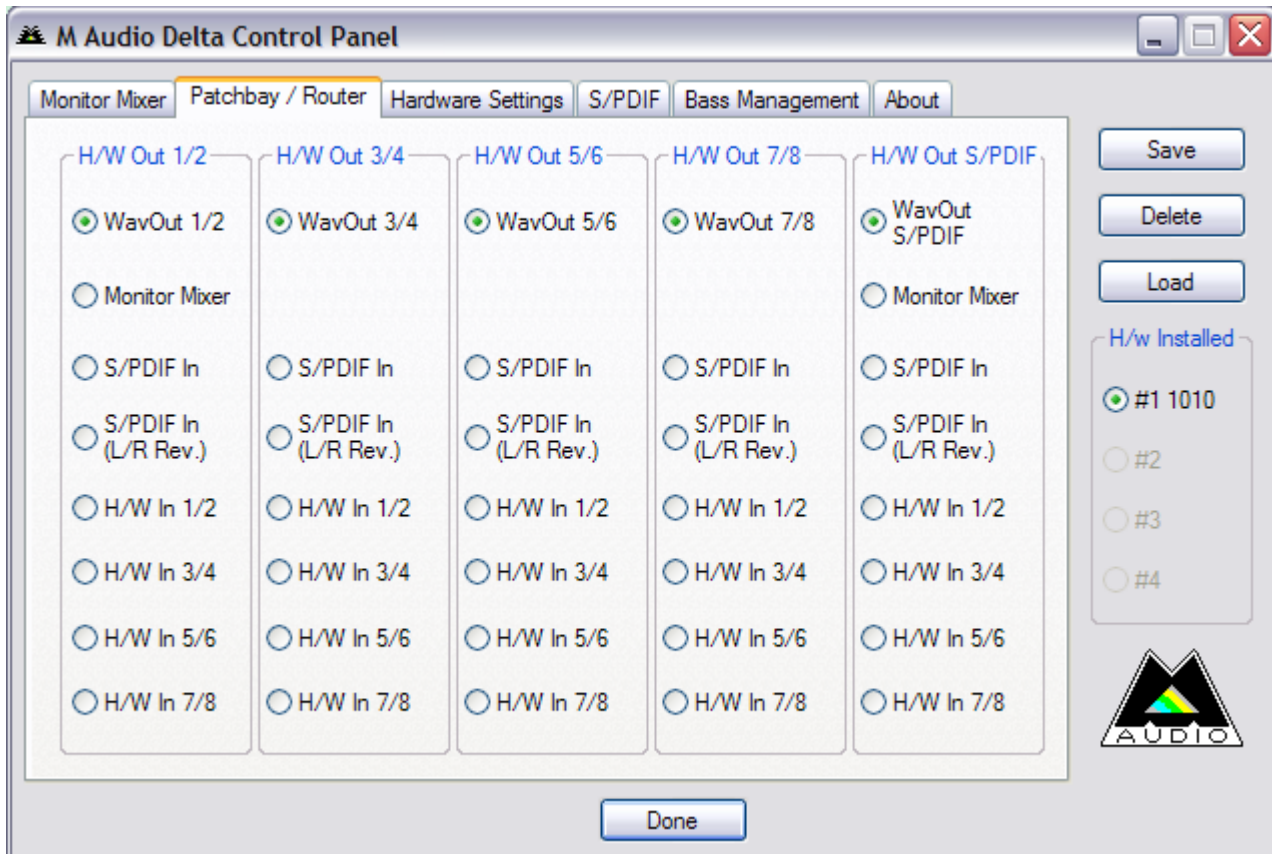

The sample rate and reference settings are made in the third tab, this is the tab where most mistakes are made so it is important to check the following items:-

Master Clock = Internal Xtal

Codec Sample Rate = 44,100 or 48,000 as suits the installation

MultiTrack Driver Devices = Independent

DMA Buffer Size (latency) = 1024

Asio/Easi Options = Disabled

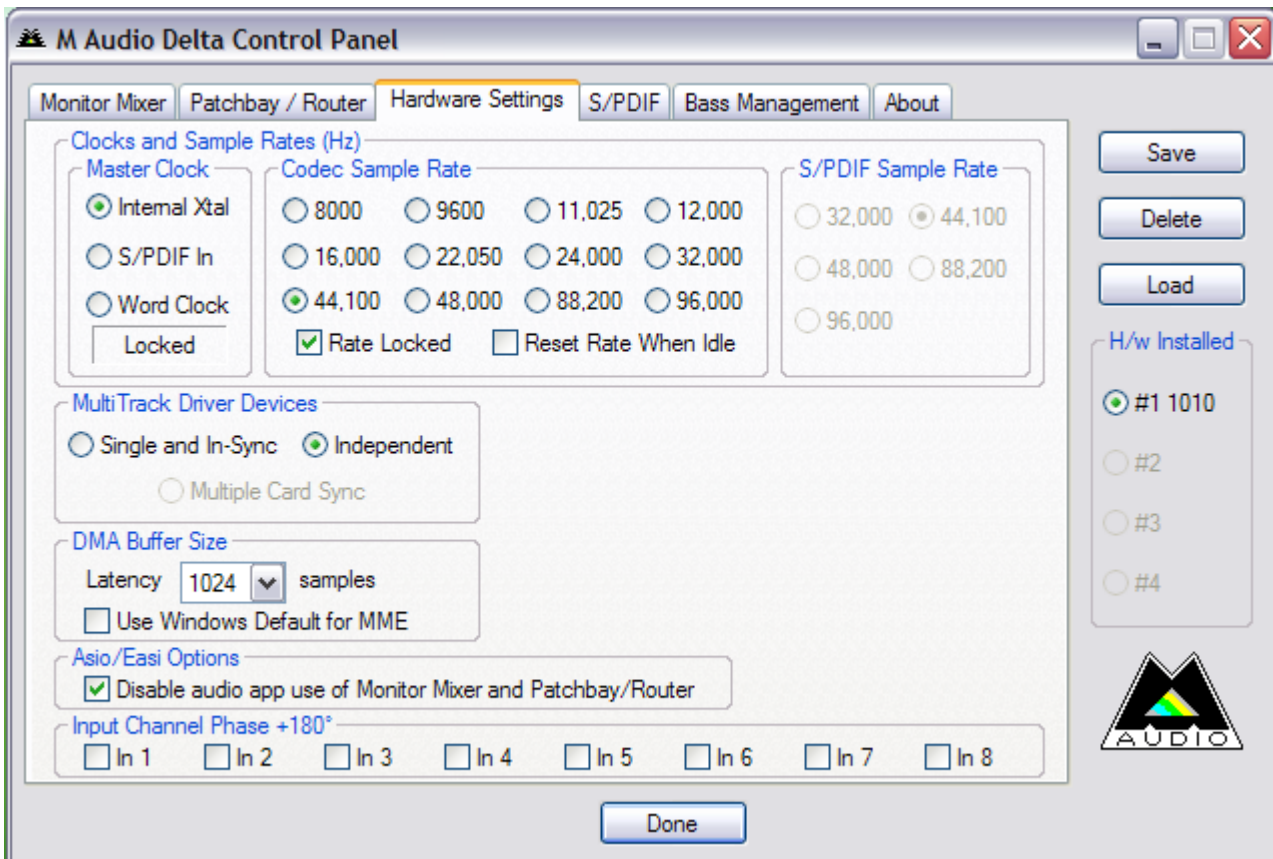

The S/PDIF page has no direct relevance to SpotOn performance and can be set as required

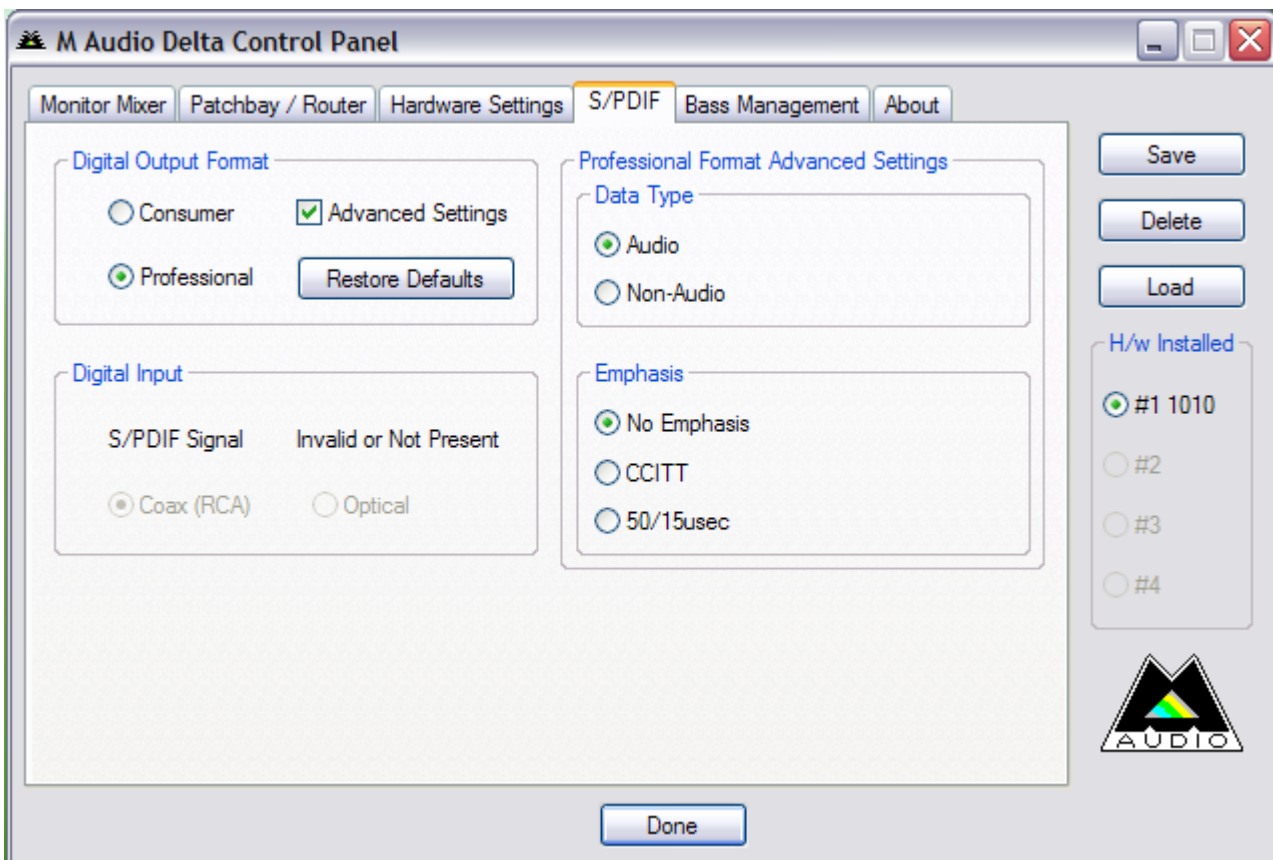

The Bass Management tab refers to surround sound effects, the M-Audio 1010 card does not directly support multichannel tracks played out from SpotOn so this tab has no effect and therefore the General Setting should be set to Off.

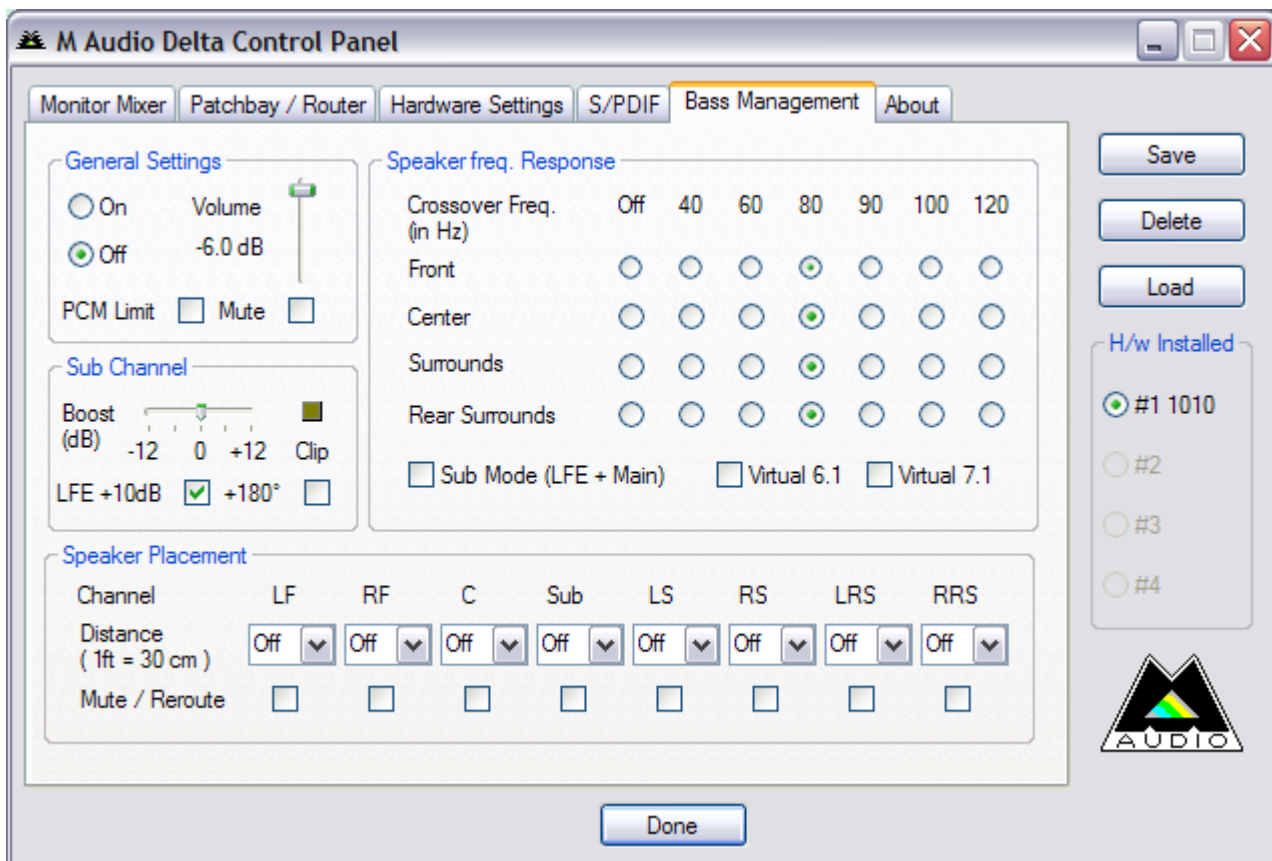

The final tab is the M-Audio About screen



The card presents itself to SpotOn as 6 entries in the Output Devices list in the case below appearing as o/p/s A..F:-

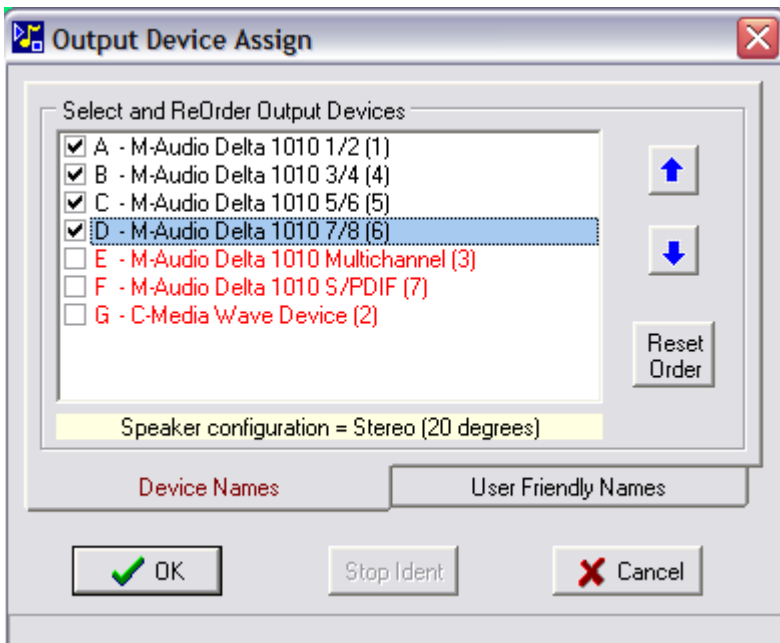

Only the first four outputs are required so o/p's E and F have been masked out and are shown in red text.

The manufacturers default device names can be replaced with something slightly more meaningful as below:-

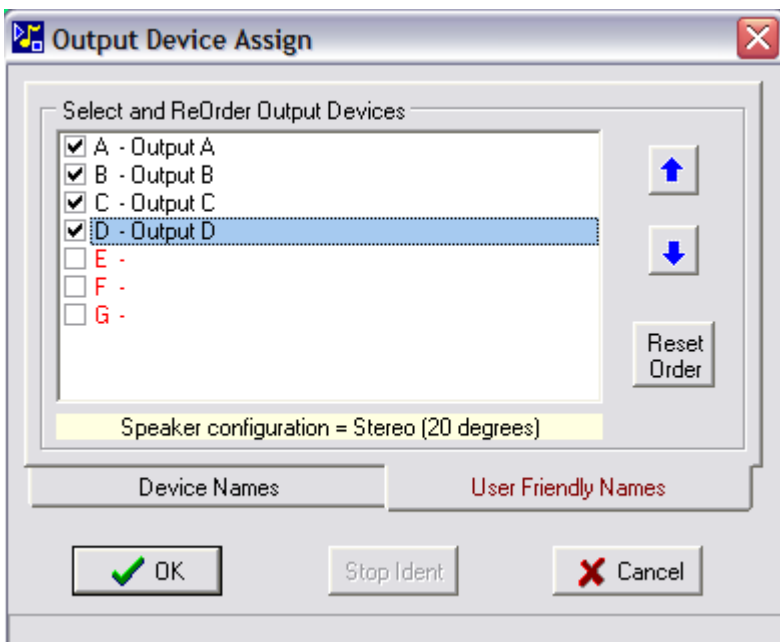

Screen shots of the later version of the MAudio control panel are shown below

**M-Audio Delta Control Panel** [min] [max] [close]

mixer | **output** | hardware | about

master	1/2 in	3/4 in	5/6 in	7/8 in	spdif in
bal <C>	bal <C>	bal <C>	bal <C>	bal <C>	bal <C>
0 2 5 10 20 30 50 100	0 2 5 10 20 30 50 100	0 2 5 10 20 30 50 100	0 2 5 10 20 30 50 100	0 2 5 10 20 30 50 100	0 2 5 10 20 30 50 100
mute   mute link	pan L pan R L127 R127 solo   solo mute   mute link	pan L pan R L127 R127 solo   solo mute   mute link	pan L pan R L127 R127 solo   solo mute   mute link	pan L pan R L127 R127 solo   solo mute   mute link	pan L pan R L127 R127 solo   solo mute   mute link

settings  
load | save  
reset | delete

-- select PCI card --

Delta 1010

M-AUDIO

**M-Audio Delta Control Panel** [min] [max] [close]

mixer | **output** | hardware | about

spdif in	sw 1/2 rtn	sw 3/4 rtn	sw 5/6 rtn	sw 7/8 rtn	spdif rtn
bal <C>	bal <C>	bal <C>	bal <C>	bal <C>	bal <C>
0 2 5 10 20 30 50 100	0 2 5 10 20 30 50 100	0 2 5 10 20 30 50 100	0 2 5 10 20 30 50 100	0 2 5 10 20 30 50 100	0 2 5 10 20 30 50 100
pan L pan R L127 R127 solo   solo mute   mute link	pan L pan R L127 R127 solo   solo mute   mute link	pan L pan R L127 R127 solo   solo mute   mute link	pan L pan R L127 R127 solo   solo mute   mute link	pan L pan R L127 R127 solo   solo mute   mute link	pan L pan R L127 R127 solo   solo mute   mute link

settings  
load | save  
reset | delete

-- select PCI card --

Delta 1010

M-AUDIO

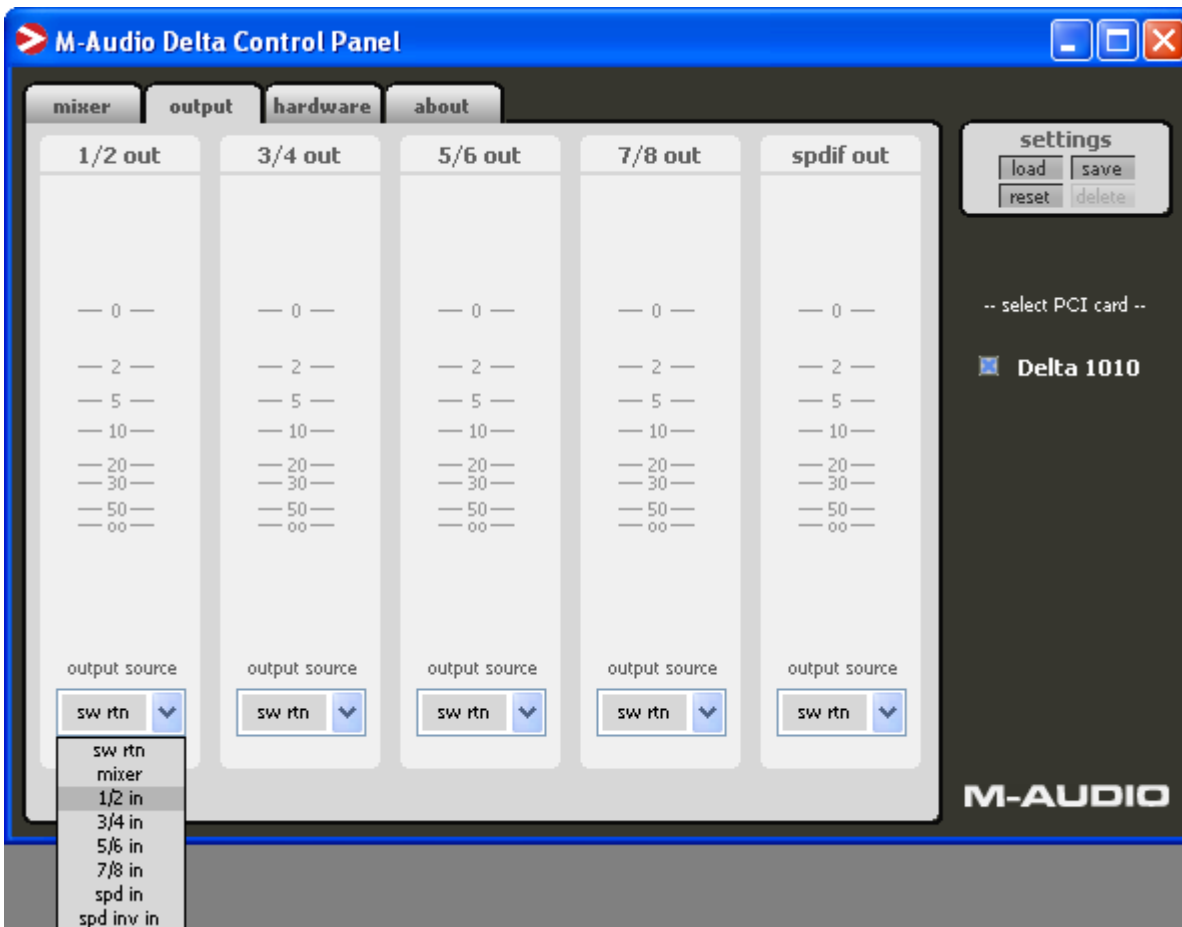
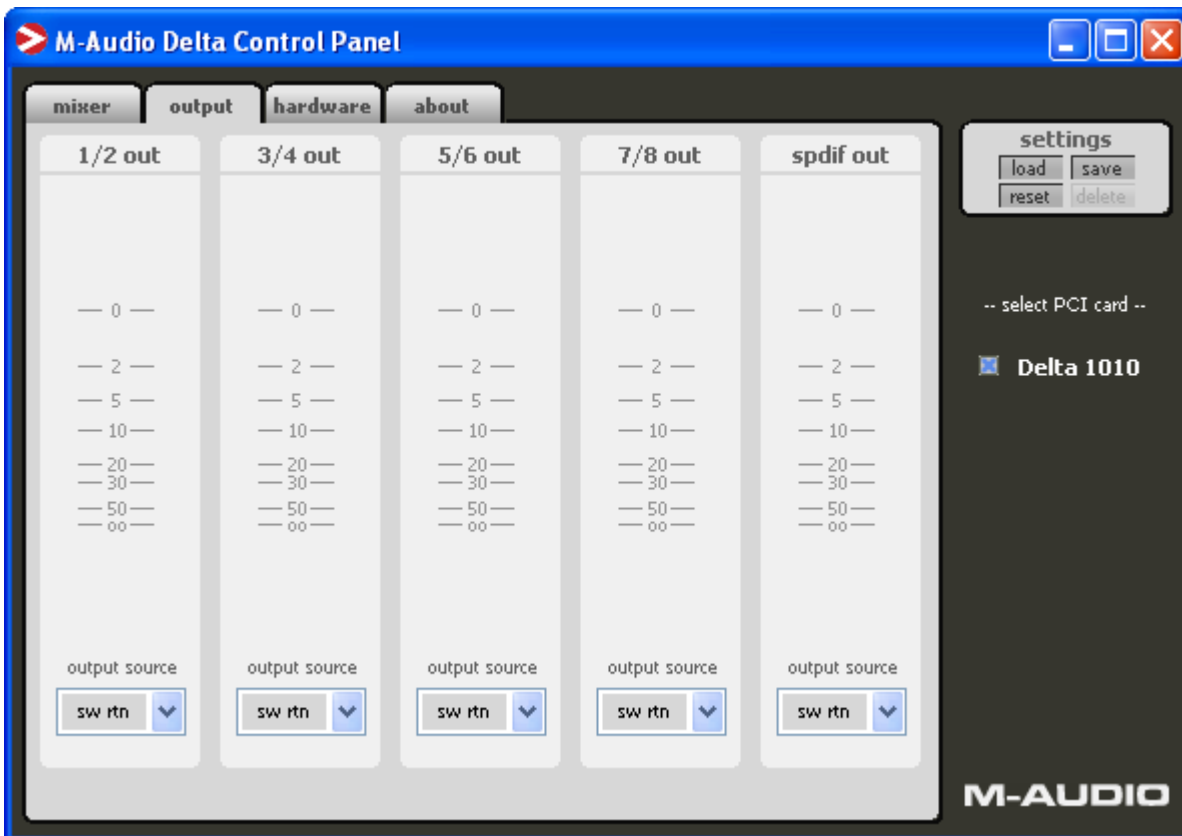

**M-Audio Delta Control Panel**

mixer output hardware about

**sample settings**

sample rate  
 Hz

ASIO/WDM buffer size  
 samples

**sync source**

locked

internal  
 external - spdif  
 external - word clock

**settings**

-- select PCI card --

**Delta 1010**

**spdif settings**

mode:   
emphasis:   
data type:   
smcs:

**other settings**

disable asio direct monitoring

invert analog ins

1 2 3 4 5 6 7 8

**M-AUDIO**

**M-Audio Delta Control Panel**

mixer output hardware about



**DELTA SERIES**

**settings**

-- select PCI card --

**Delta 1010**

**web links**

**panel:** 5.10.0.5065  
**driver:** 5.10.0.5065

**M-AUDIO**

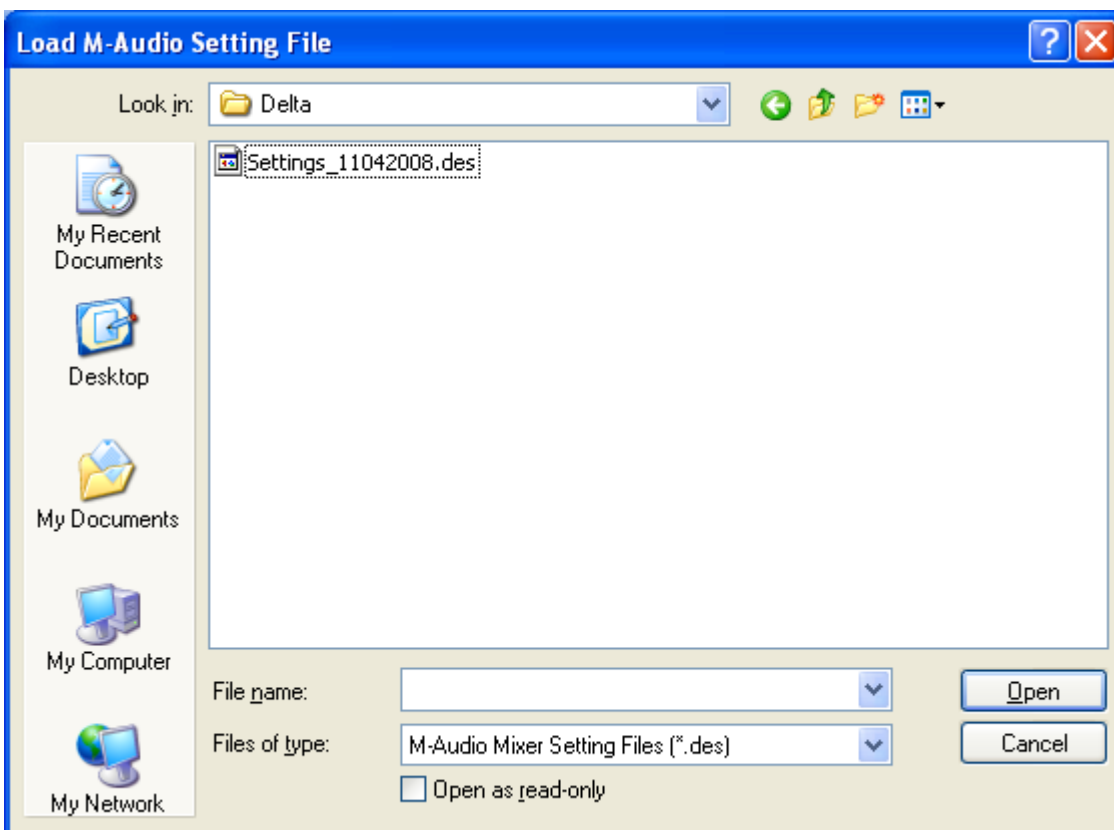
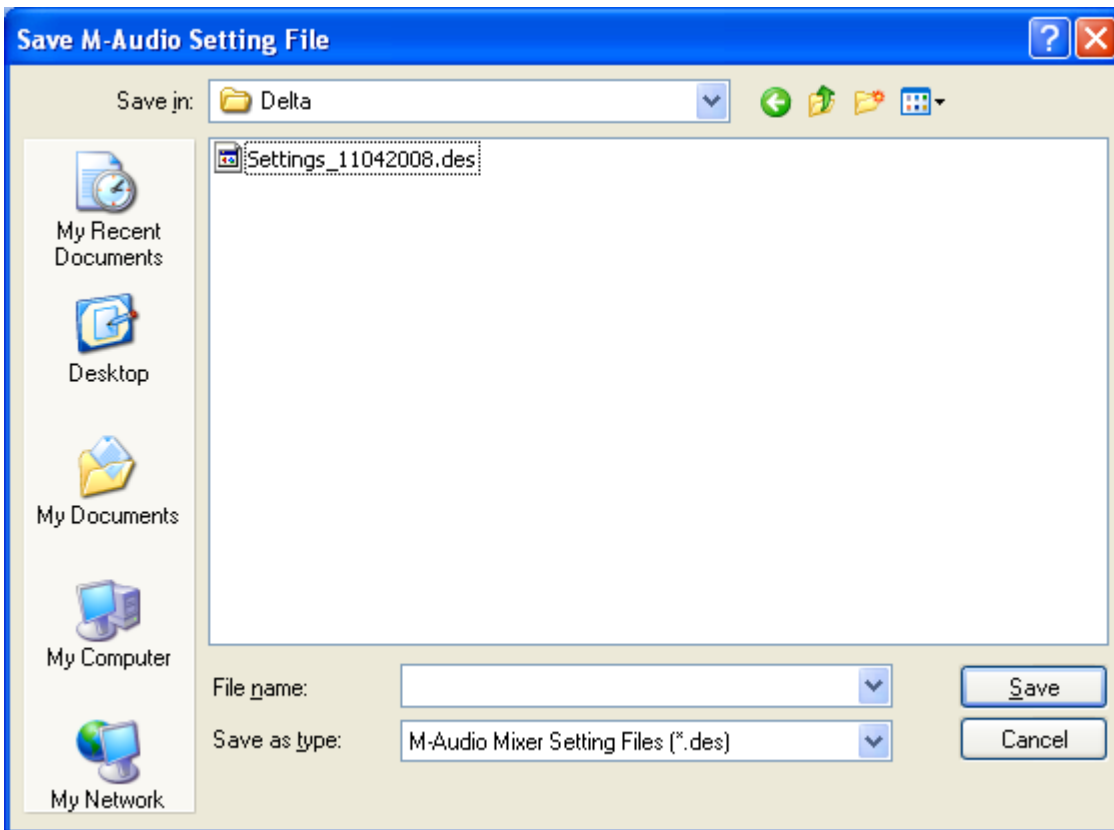

## RME HDSP AES-32



The setup of the RME cards involves two utilities Settings and Matrix/Mixer which will normally be available directly from the taskbar system tray.



The description on this page refers to the HDSP AES-32 card, for other RME cards see [HDSP MADI](#), [Fireface 800](#) or [Multiface II](#)

The Settings utility has three tabs, on the first tab it is important to uncheck the SyncAlign option as if left checked will prevent SpotOn from playing out tracks.

The AES output can be locked (Clock Mode) by one of two methods AutoSync and Master .

In AutoSync mode the preferred locking reference for the AES output is selected on the right hand side of the 'Input Status/Pref. Sync Ref' section, if the preferred reference is not present then the inputs will be scanned until a valid locking signal is found. If no valid locking signal is present then the card will revert to an internal reference.

In Master mode the card locks to the internal reference.

The System Clock section shows the current lock method and frequency.

The Output Format section should have the 'Professional' option checked as some broadcast equipment will reject AES data that does not have this flag set.

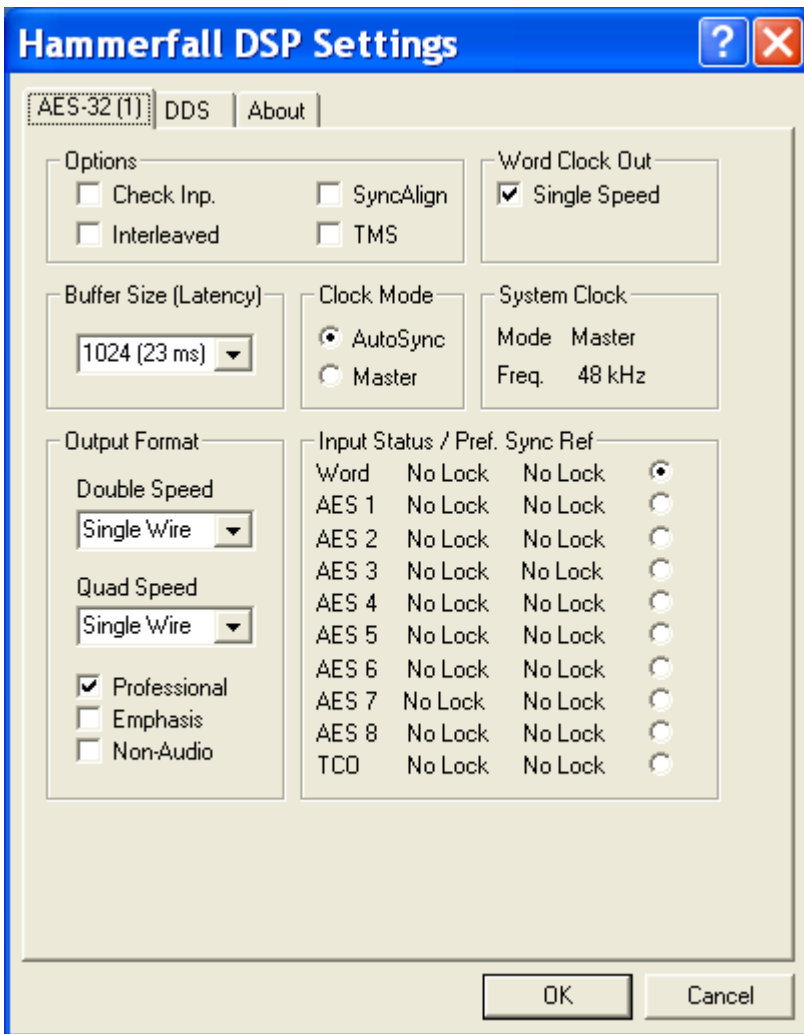

The second tab titled DDS (Direct Digital Synthesiser) should be set Active by checking the DDS Active option and the Frequency (kHz) set to 48.000. The card uses these settings when set to internal Master reference.

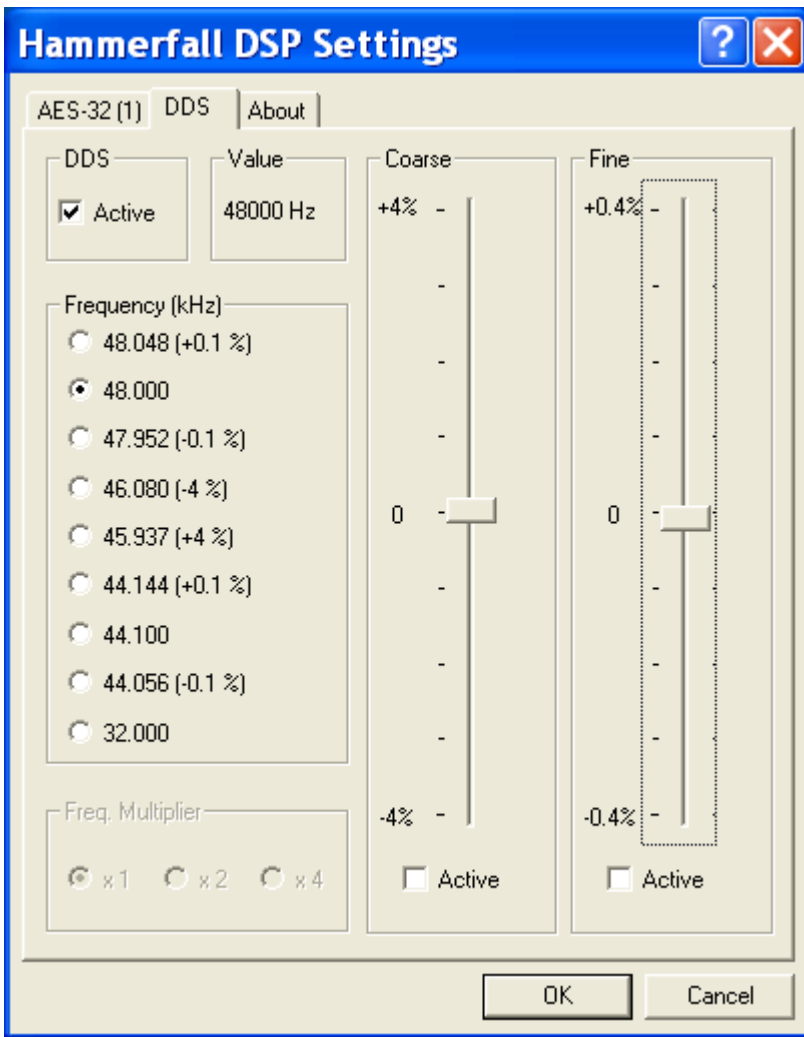

The last tab shows the About information, the tests were conducted using the Beta v17 WDM drivers

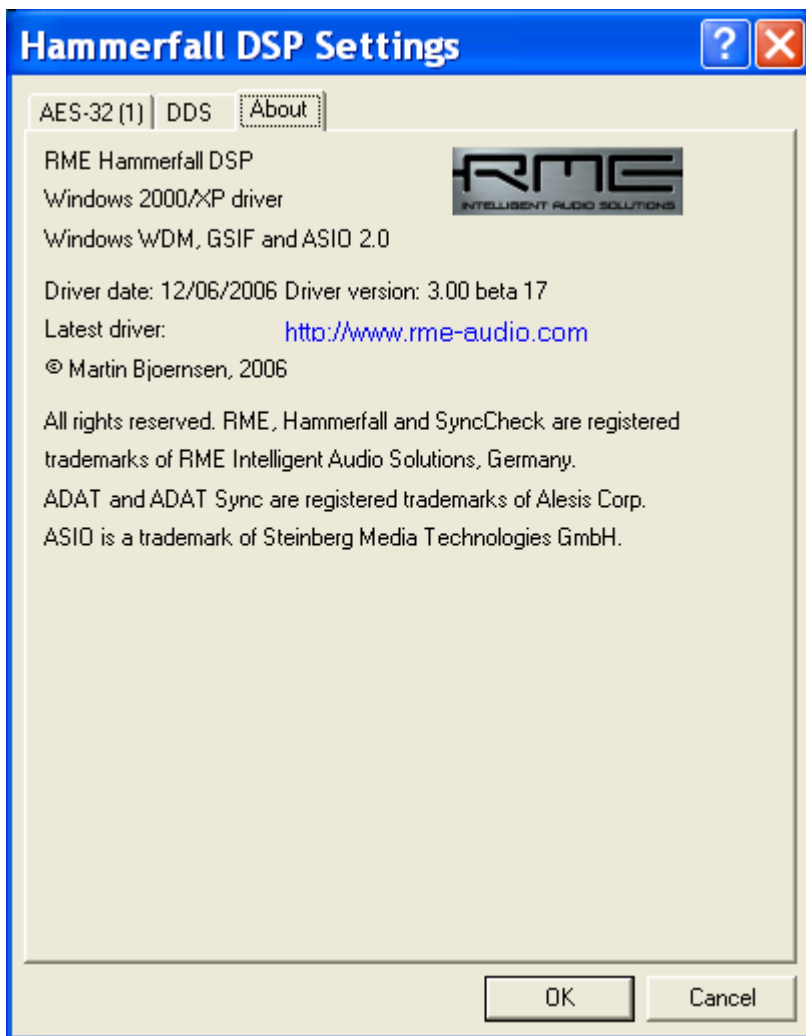

The Matrix utility allows the software output channels of the card to be routed to hardware outputs, the patch is normally 1:1 so that software output 1/2 is routed to hardware output 1/2 etc.

The card has 8 stereo outputs and the 16 individual channels are paired 1+2, 3+4, 5+6, 7+8, 9+10, 11+12, 13+14, 15+16.

HDSP Matrix (1)																	X
	1	2	3	4	5	6	7	8	9	10	11	12	13	14	15	16	
In 1																	In 1
In 2																	In 2
In 3																	In 3
In 4																	In 4
In 5																	In 5
In 6																	In 6
In 7																	In 7
In 8																	In 8
In 9																	In 9
In 10																	In 10
In 11																	In 11
In 12																	In 12
In 13																	In 13
In 14																	In 14
In 15																	In 15
In 16																	In 16
Out 1	0.0																Out 1
Out 2		0.0															Out 2
Out 3			0.0														Out 3
Out 4				0.0													Out 4
Out 5					0.0												Out 5
Out 6						0.0											Out 6
Out 7							0.0										Out 7
Out 8								0.0									Out 8
Out 9									0.0								Out 9
Out 10										0.0							Out 10
Out 11											0.0						Out 11
Out 12												0.0					Out 12
Out 13													0.0				Out 13
Out 14														0.0			Out 14
Out 15															0.0		Out 15
Out 16																0.0	Out 16
1	2	3	4	5	6	7	8	9	10	11	12	13	14	15	16		

If the software outputs 3+4 are required to appear on hardware outputs 1+2, and software outputs 1+2 are to appear on hardware outputs 3+4 the following patch should be made

HDSP Matrix (1)																	X
	1	2	3	4	5	6	7	8	9	10	11	12	13	14	15	16	
In 1																	In 1
In 2																	In 2
In 3																	In 3
In 4																	In 4
In 5																	In 5
In 6																	In 6
In 7																	In 7
In 8																	In 8
In 9																	In 9
In 10																	In 10
In 11																	In 11
In 12																	In 12
In 13																	In 13
In 14																	In 14
In 15																	In 15
In 16																	In 16
Out 1			0.0														Out 1
Out 2				0.0													Out 2
Out 3	0.0																Out 3
Out 4		0.0															Out 4
Out 5					0.0												Out 5
Out 6						0.0											Out 6
Out 7							0.0										Out 7
Out 8								0.0									Out 8
Out 9									0.0								Out 9
Out 10										0.0							Out 10
Out 11											0.0						Out 11
Out 12												0.0					Out 12
Out 13													0.0				Out 13
Out 14														0.0			Out 14
Out 15															0.0		Out 15
Out 16																0.0	Out 16
1	2	3	4	5	6	7	8	9	10	11	12	13	14	15	16		

Consult the sound card manual for operation of the Mixer utility.

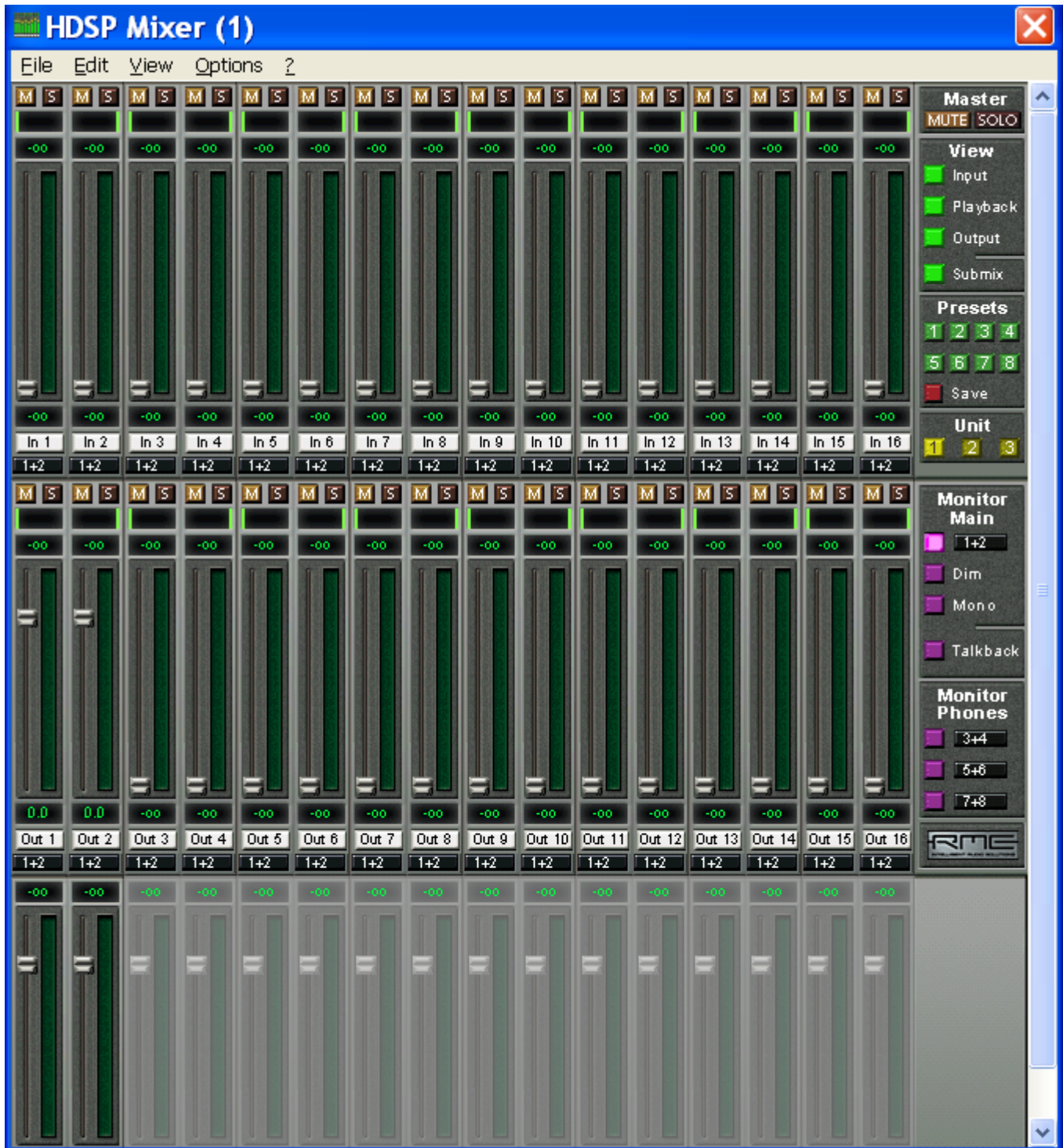

Sound card software outputs are listed as 8 stereo pairs, here shown as F..M

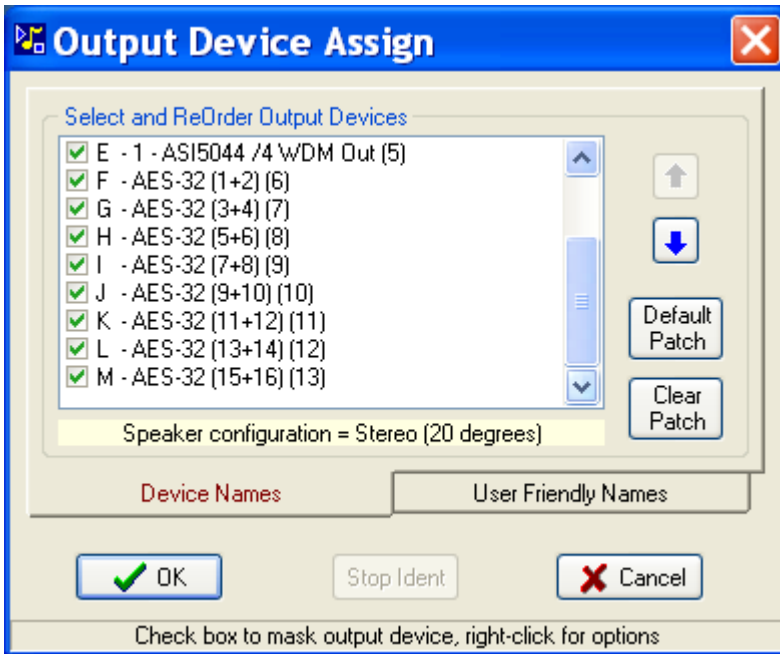

To use the RME card in multi-channel mode the 'interleaved' option must be checked on the first tab of the settings dialog

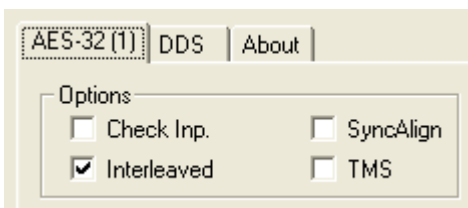

SpotOn must be restarted for this configuration change to be registered

With SpotOn in MultiChannel mode playing a multi-channel interleaved WAV file to outputs "1+2" will result in the individual channels appearing on outputs 1..8, similarly playing an interleaved WAV file on outputs "9+10" will result in the individual channels appearing on outputs 9..16.

Note that the remaining stereo output pairs 3+4, 5+6, 7+8, 11+12, 13+14 and 15+16 should not be used when in 'interleaved' mode as the results are unpredictable. Therefore these outputs must be masked in the Output Device Assign window as shown below.

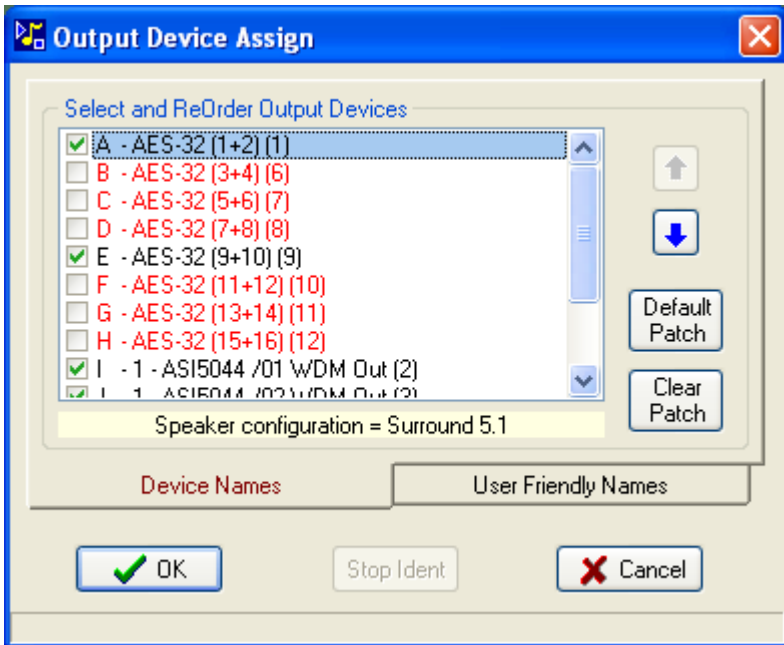

The image below shows a 5.1 interleaved WAV test file playing with tone on all 6 channels.



The configuration of this card can be more than a little confusing, the default operation with all software outputs routed to hardware outputs and all hardware inputs not contributing to hardware outputs can be recalled by using Preset 1



Make sure that this preset is not overwritten with the Save button

With some of the versions of the RME AES-32 sound card drivers prior to v3.0.66 the multichannel outputs appear in the incorrect order of 1,2,3,4,7,8 instead of 1,2,3,4,5,6 this can be corrected by either externally repatching the output cables or internally using the RME Matrix utility - see [RME SetUp](#)

The card has 2 MIDI input and 2 MIDI output channels, these will be shown in the SpotOn SetUp | Midi Devices menu.

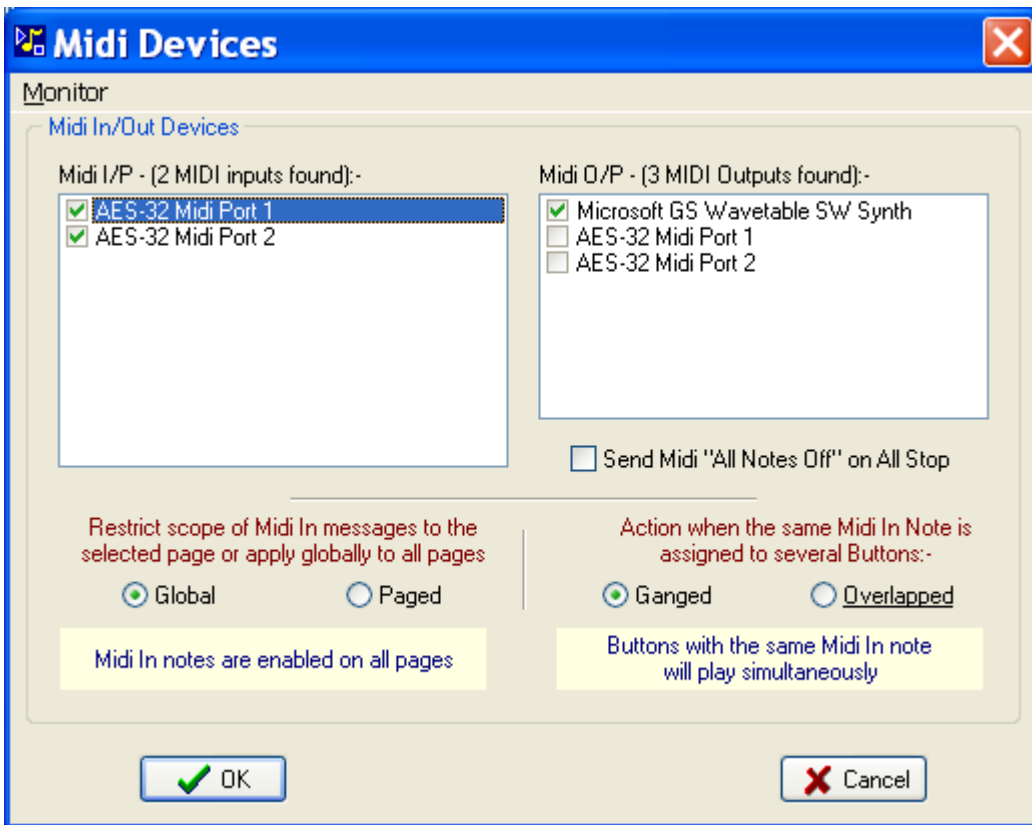

Windows Control Panel 'Sounds and Audio Devices' applet lists the 8 stereo outputs and inputs

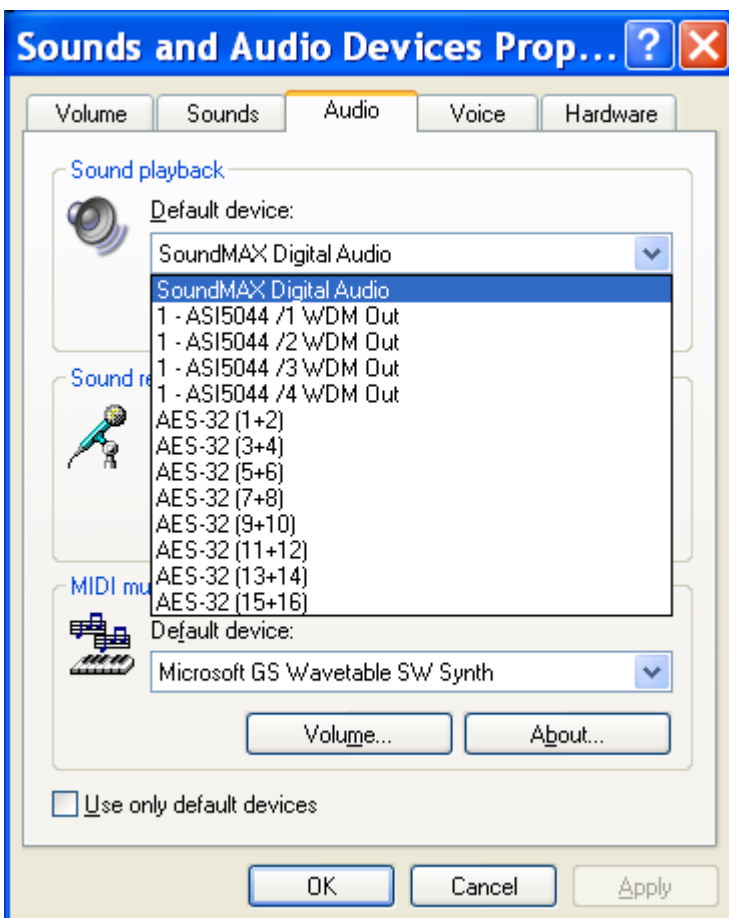

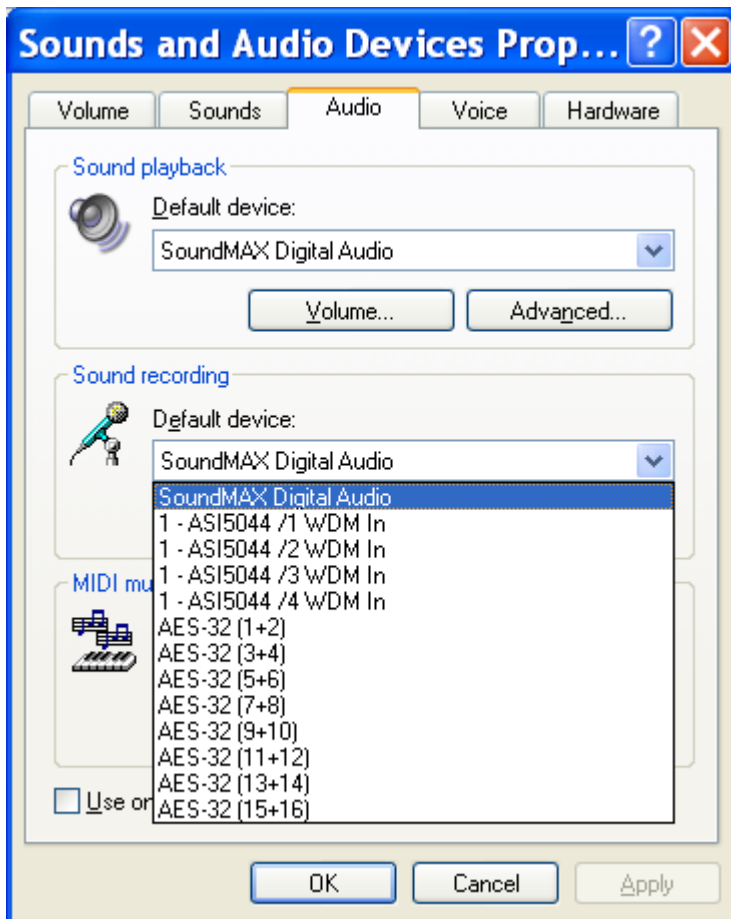

The 2 channels of MIDI are also listed.

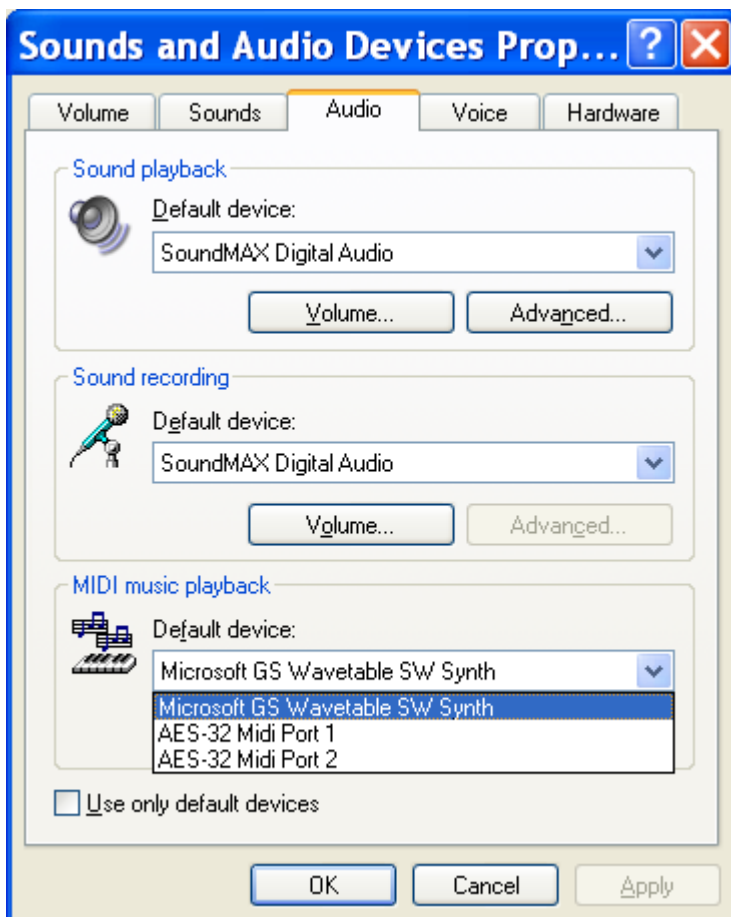

# RME SetUp

With some of the versions of the RME AES-32 sound card drivers prior to v3.0.66 the multichannel outputs appear in the incorrect order of 1,2,3,4,7,8 instead of 1,2,3,4,5,6 this can be corrected by either externally repatching the output cables or internally using the RME Matrix utility.

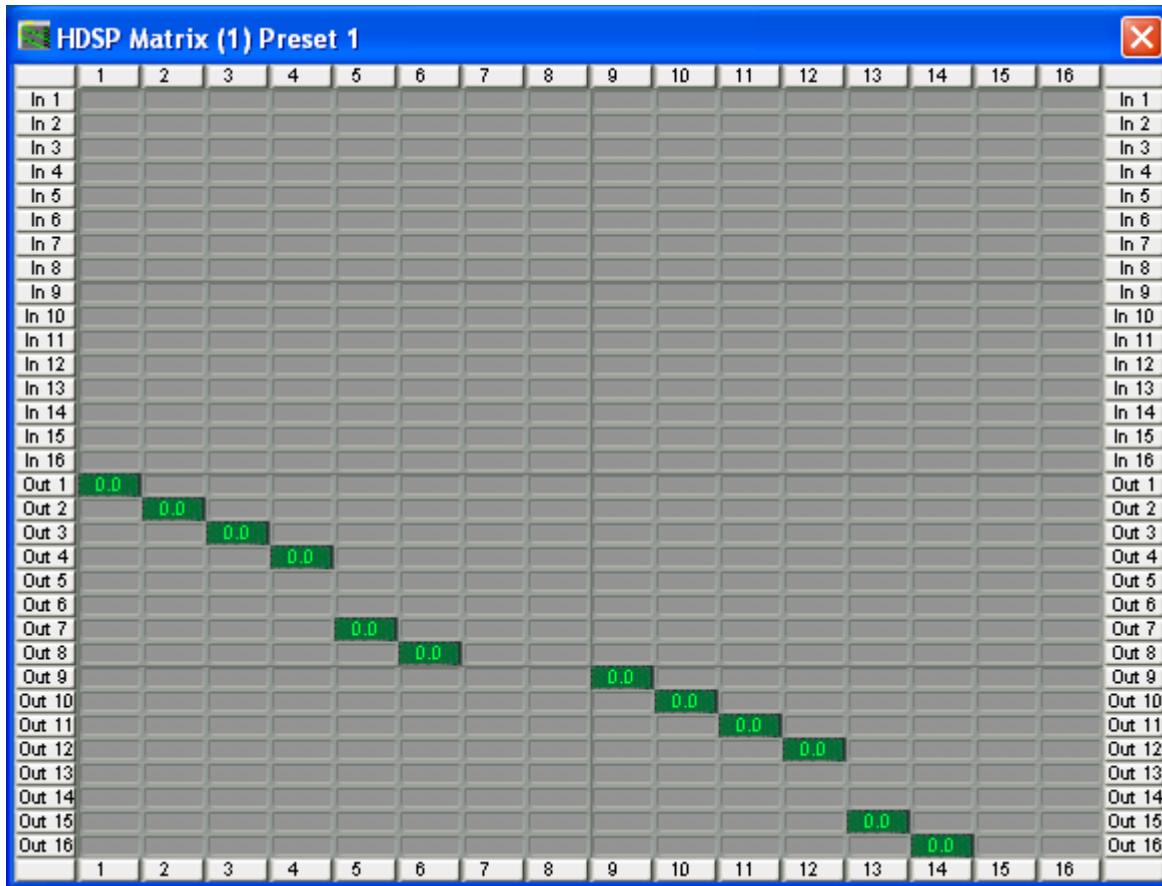

The screenshot shows the 'HDSP Matrix (1) Preset 1' window. It features a 16x16 grid of input and output channels. The columns are labeled 'In 1' through 'In 16' and the rows are labeled 'Out 1' through 'Out 16'. The matrix is currently set to a diagonal configuration, with green cells containing '0.0' indicating a 1:1 connection between each input and output channel. The connections are as follows:

Output	In 1	In 2	In 3	In 4	In 5	In 6	In 7	In 8	In 9	In 10	In 11	In 12	In 13	In 14	In 15	In 16
Out 1	0.0															
Out 2		0.0														
Out 3			0.0													
Out 4				0.0												
Out 5					0.0											
Out 6						0.0										
Out 7							0.0									
Out 8								0.0								
Out 9									0.0							
Out 10										0.0						
Out 11											0.0					
Out 12												0.0				
Out 13													0.0			
Out 14														0.0		
Out 15															0.0	
Out 16																0.0

Alternatively the same result can be obtained using the AES-32 Mixer:-

First route SpotOn o/p 1 to physical output 1



Next route SpotOn o/p 2 to physical output 2

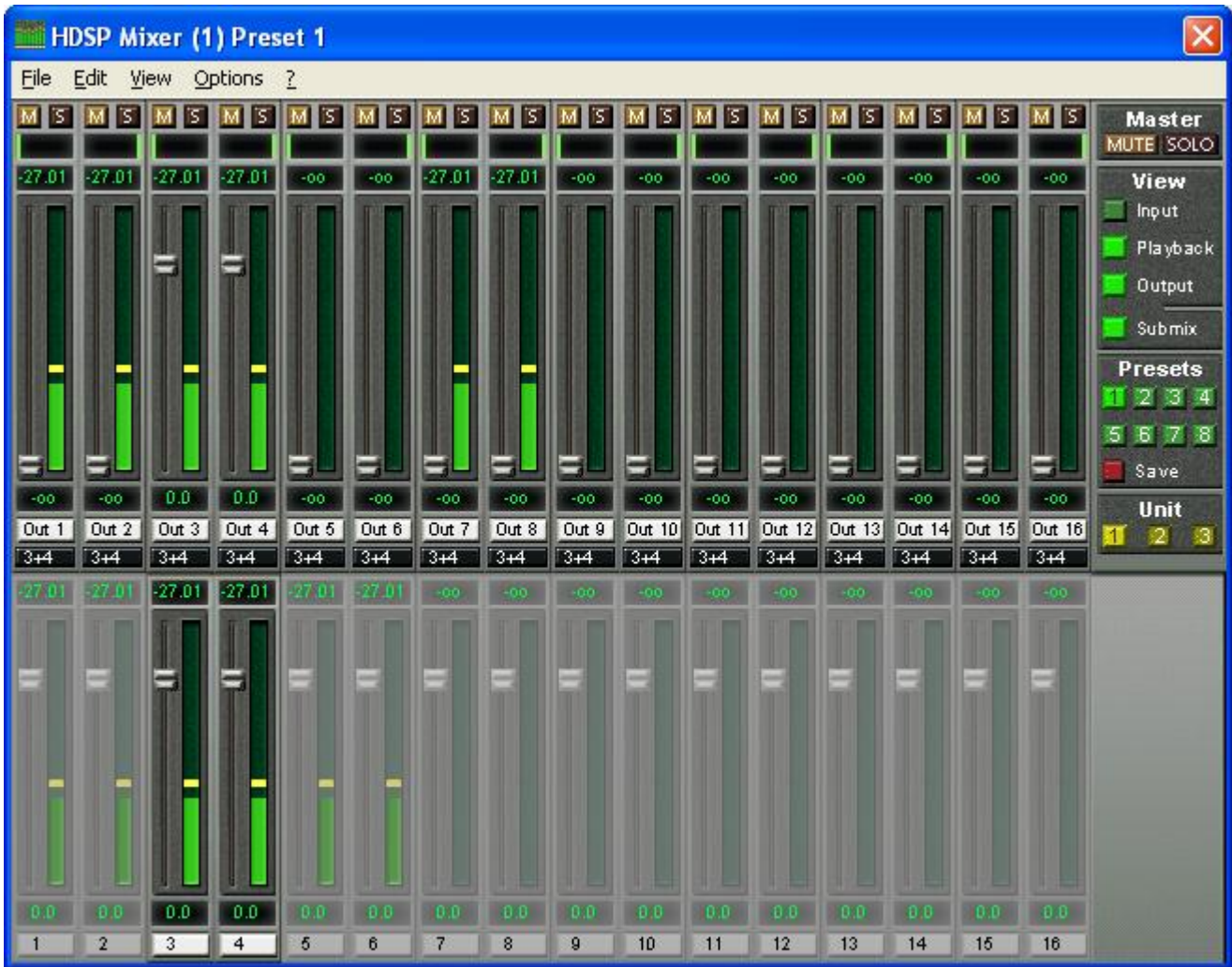

This time set the physical outputs 5+6 to take the audio from SpotOn 7+8

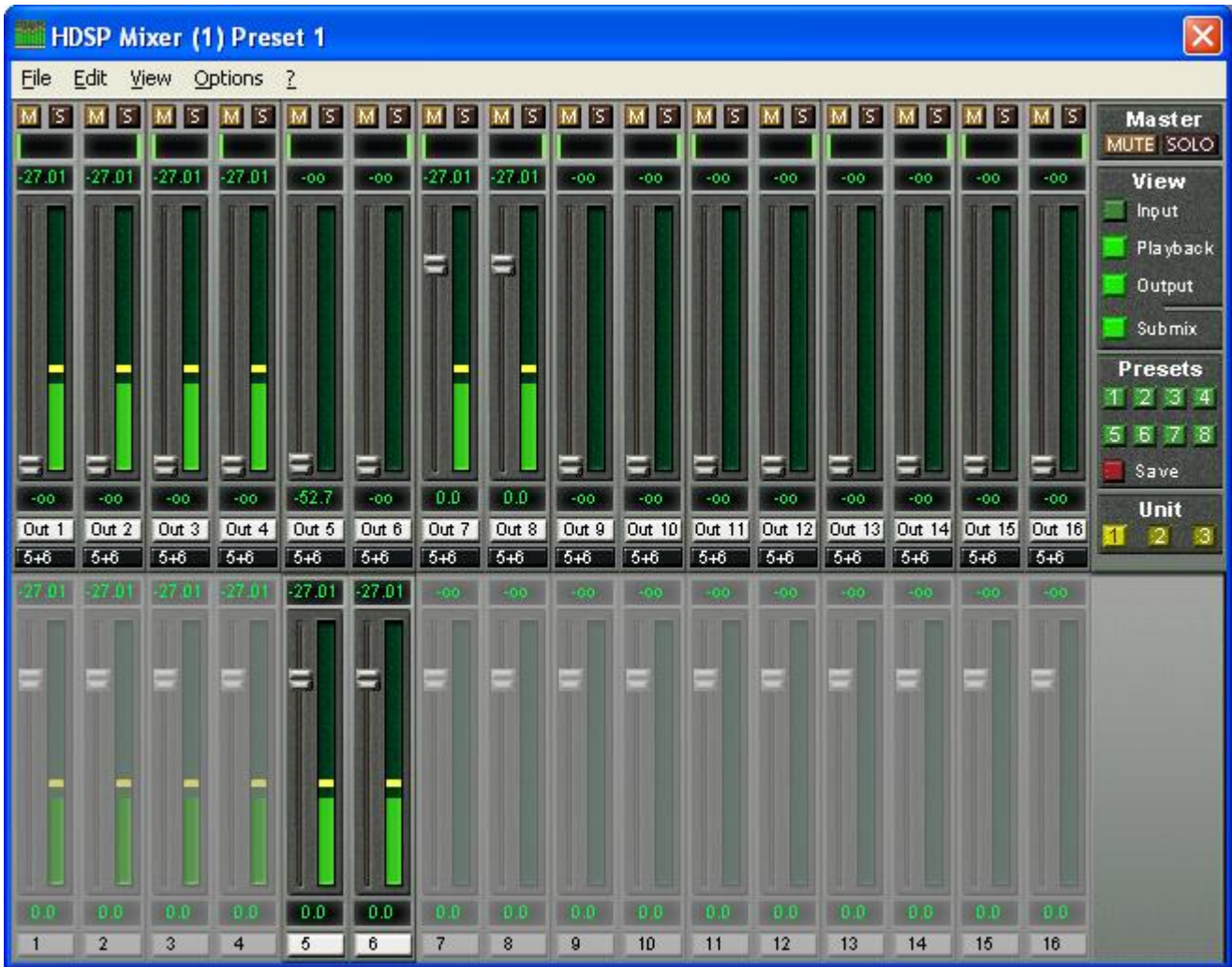

Finally mute the contribution of SpotOn o/ps 7+8 to physical outputs 7+8



Save this configuration by pressing the Red Save button and then Preset 2, note Preset 1 contains the default settings.

# RME HDSP MADI



The RME HDSP MADI card is unusual in that it has 64 output channels, these are presented to SpotOn either as 32x stereo devices or when running in 6/8 channel surround sound mode 8x 5.1 devices.

The RME settings page is similar to their other cards.

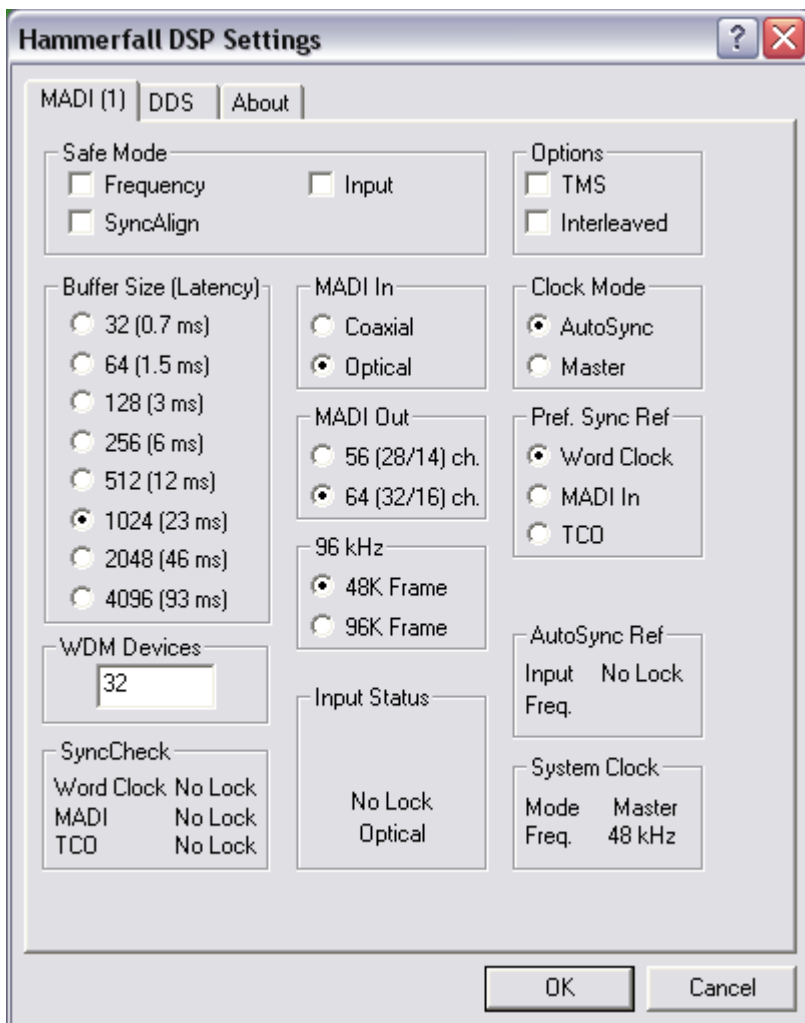

In SpotOn the outputs will be assigned as shown below as 32 stereo pairs.

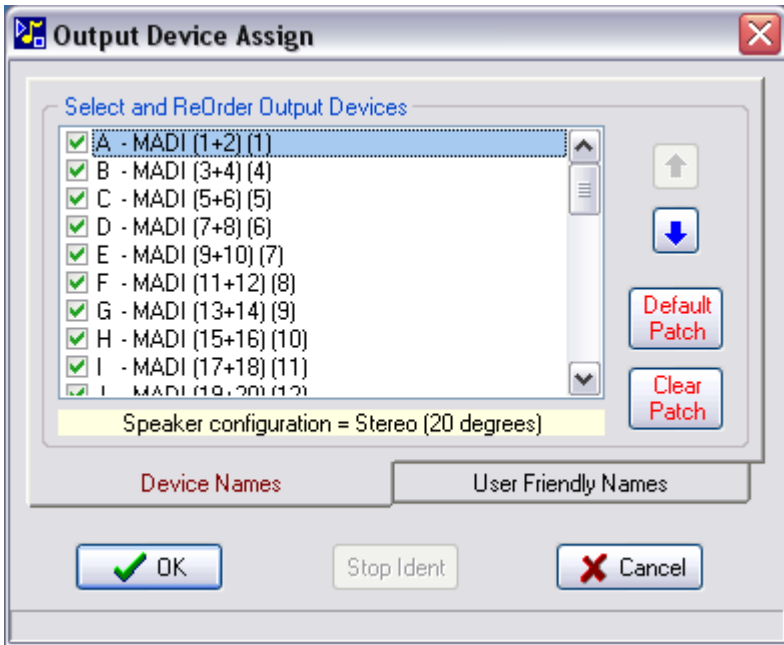

Checking the RME settings Interleaved option will convert the card to offer 8 x 7.1 output devices



In this case the SpotOn outputs have to be reconfigured to bring the surround sound channels to the top of the list, output A is on channels 1+2 and output B on channels 9+10 and so on.

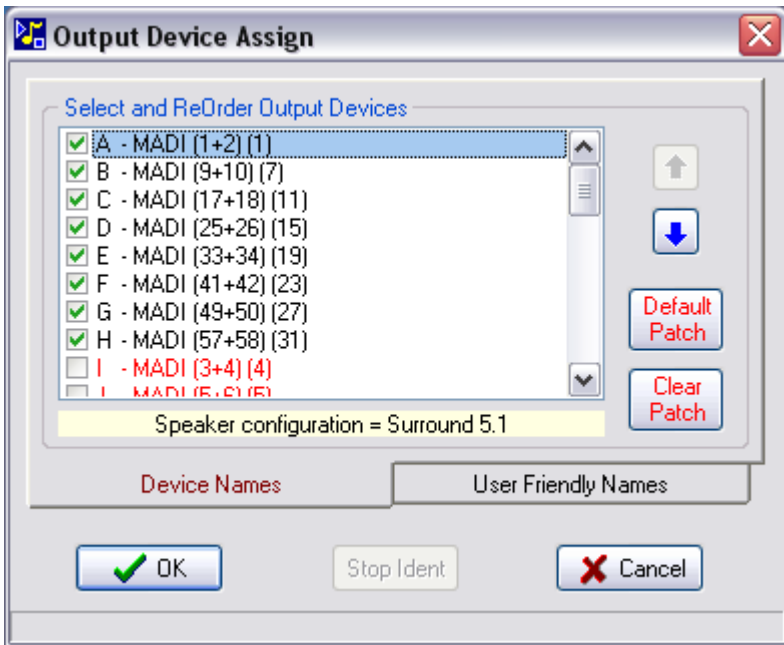

To complete the SpotOn setup the unused outputs 3..8, 11..16, >> 51..64 will have to be masked.

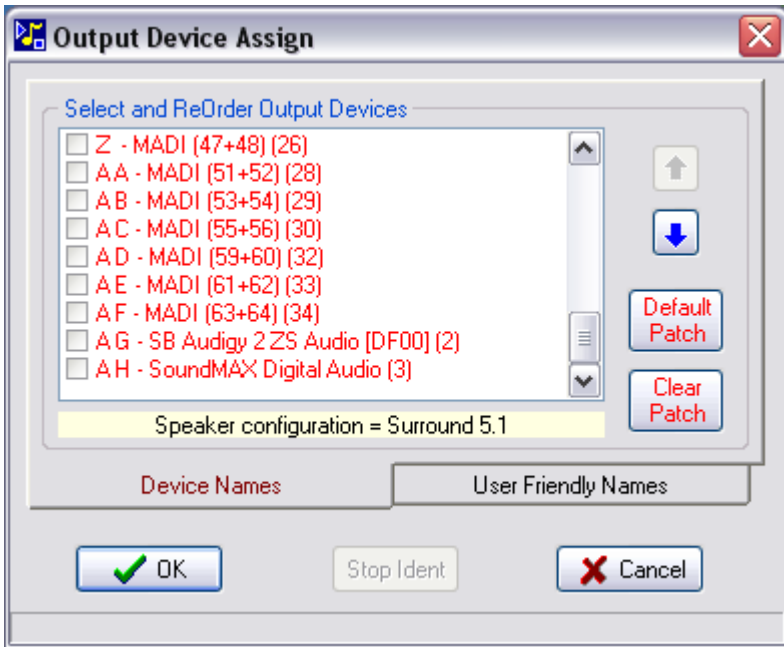

The RME 'TotalMix' utility is correspondingly large to accommodate the 64 channels, requiring a horizontal scroll bar to view all channels.

Below is a screen grab of the first 32 channels with a 5.1 (6 channel) test tone being played on SpotOn outputs A, B, C & D.

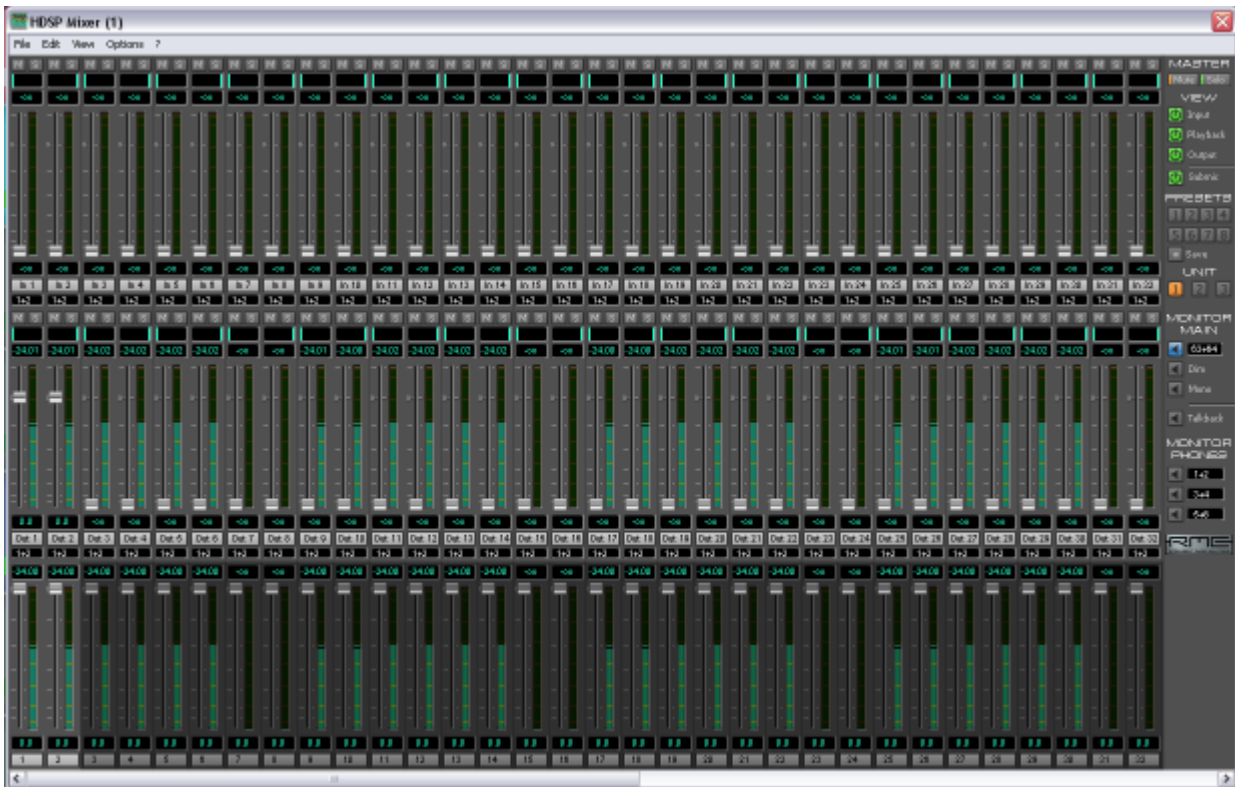

# RME Fireface 800



The RME Fireface 800 has 10 channels of output (8 main + 2 preview) available in a variety of formats, the exact setup will depend on the individual user.

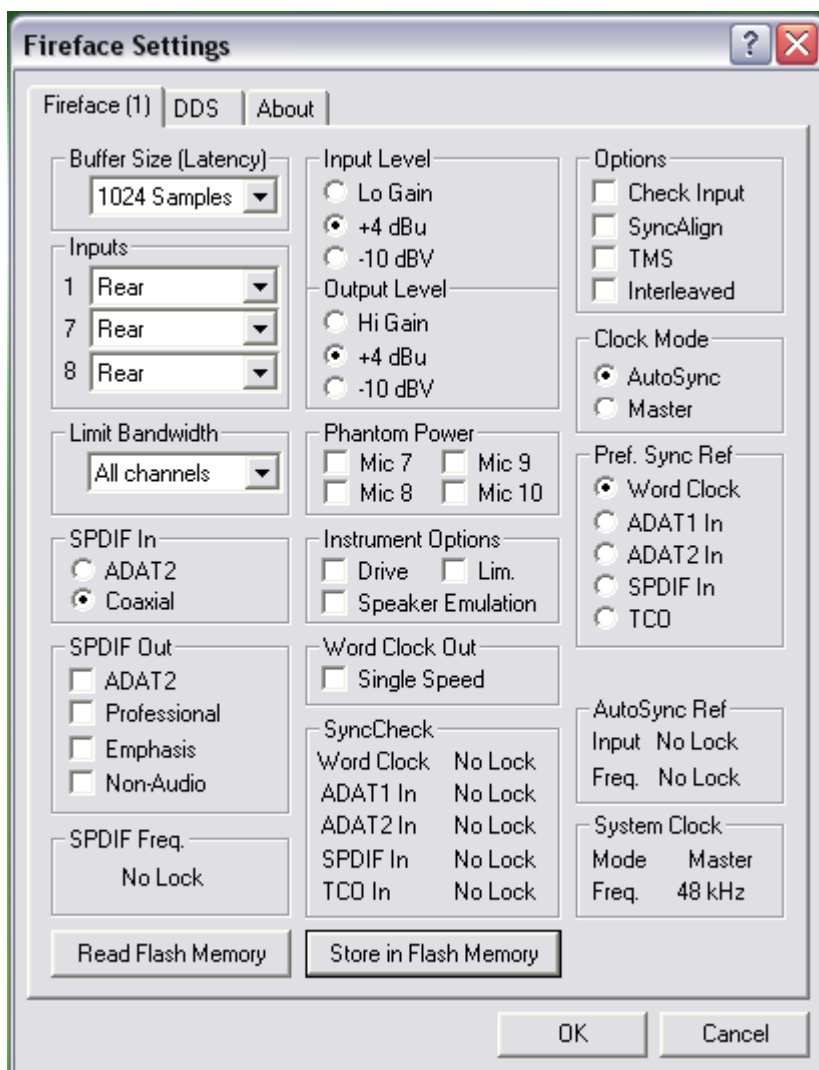

In Stereo mode with the Interleaved option unchecked, SpotOn will present the 5 stereo outputs.

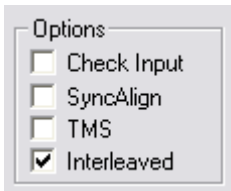
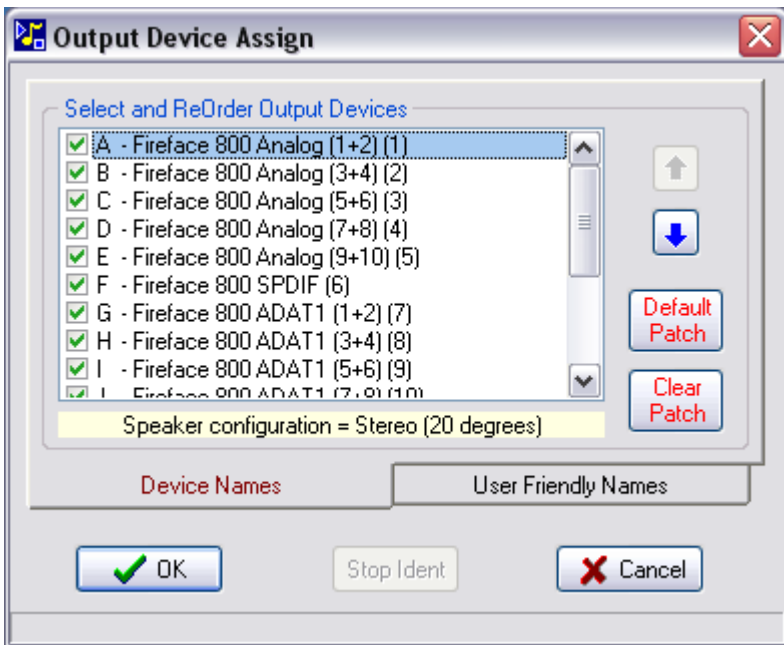

In Interleaved mode only outputs 1+2 can be used in SpotOn for either 2 channel stereo or 6 channel surround sound files.

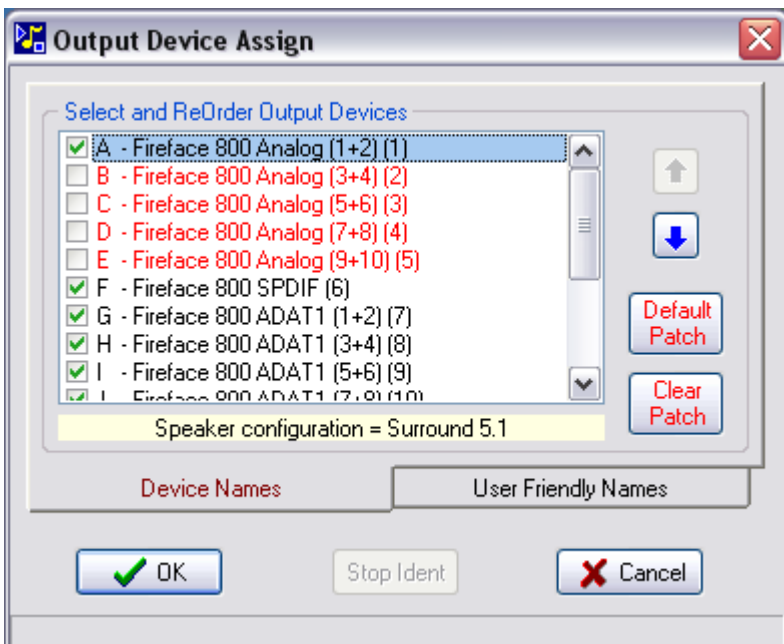

# RME Multiface II



The RME Multiface II has 8 channels of output available in a variety of formats, the exact setup will depend on the individual user.

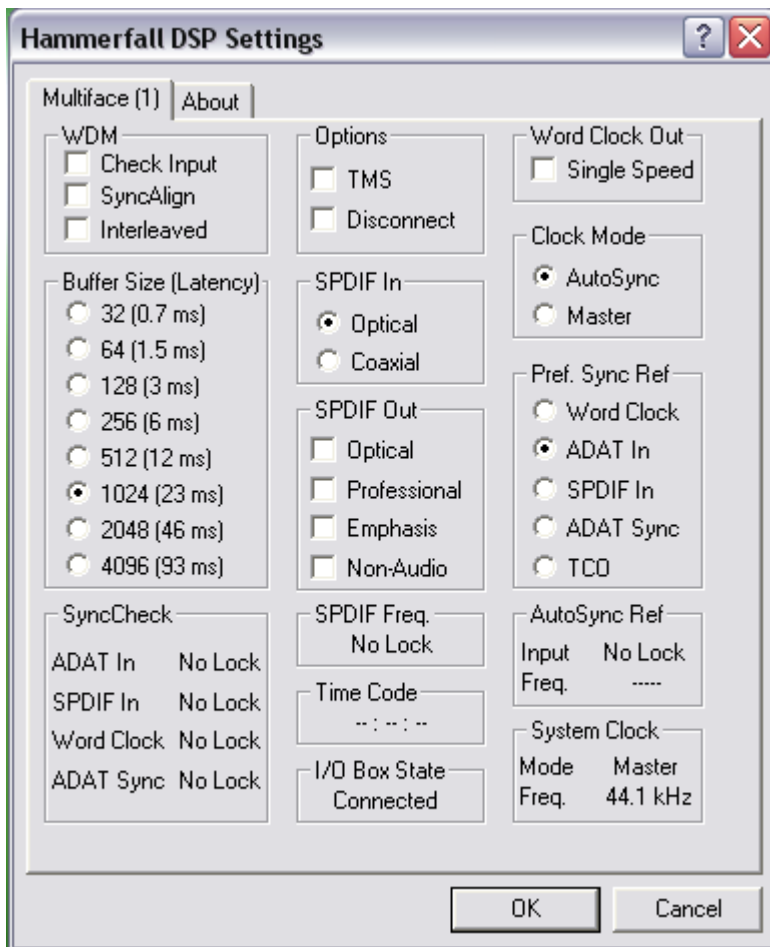

In the Stereo mode the Interleaved option is left unchecked, and SpotOn will offer a range of stereo output devices.

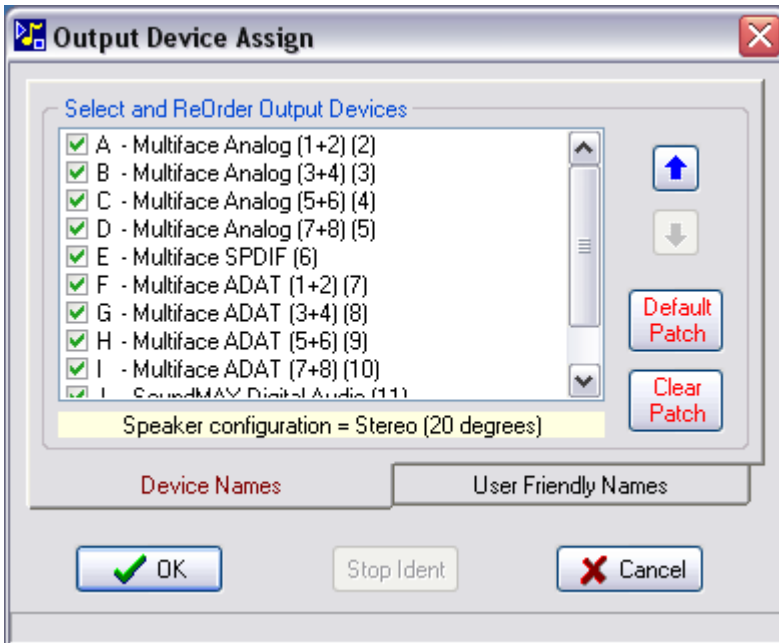

With the Interleaved option checked, the Multiface II will operate in multichannel mode.

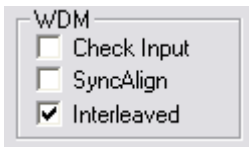

The significance of this is that only outputs 1+2 can now be used, the others 3..8 must be masked.

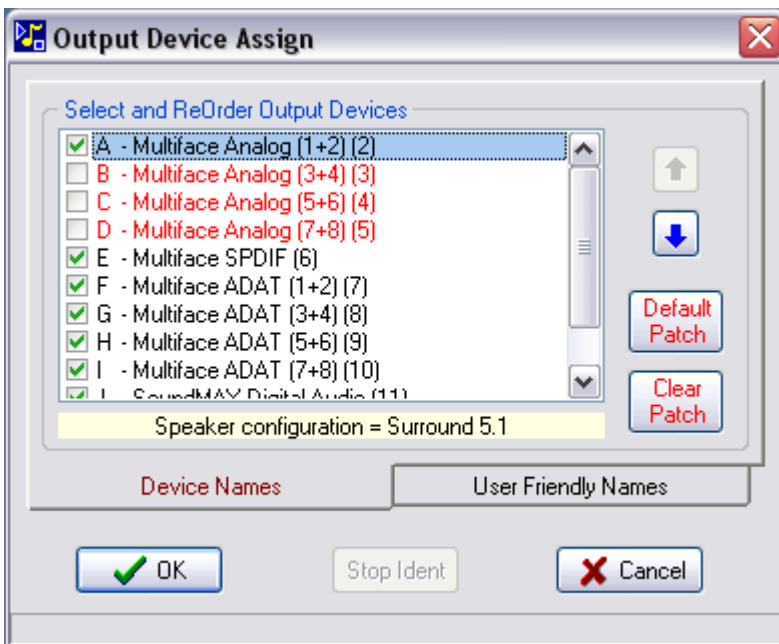

The RME 'TotalMix' utility screen shot below shows a (6 channel) 5.1 test tone playing out on SpotOn output A



# GPI Interfaces

[Game Port Connections](#)

[GPI to Midi Convertor](#)

# Game Port Connections

## Joystick/GPI

The conventional Game Port found on most Sound Cards is a 15 pin D-type socket, to use the Fire buttons as GPI inputs make the connections as described below

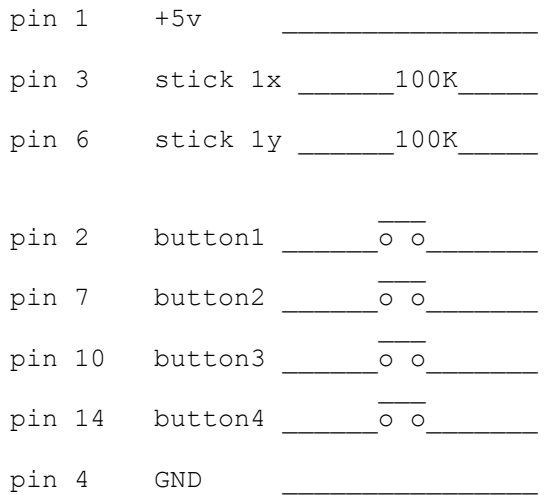

## Soundcard

-----  
1 : +5vDC  
2 : Stick 1 button 1  
3 : Stick 1 X-position  
4 : Gnd  
5 : Gnd  
6 : Stick 1 Y-position  
7 : Stick 1 button 2  
8 : +5vDC  
9 : +5vDC  
10 : Stick 2 button 1  
11 : Stick 2 X-position  
12 : MIDI  
13 : Stick 2 Y-position  
14 : Stick 2 button 2  
15 : MIDI

Take care with the routing of the +5v supply as this may not be current limited on the sound card

A suggestion below consists of two cables a D15M..D9F that remains connected to the PC and a loose cable D9M..(4 x jack plugs) that connect to the GPI sources.

The advantage of this is that the two resistors on pins 3/6 of the D15M are always connected to the PC, and so avoids the situation where the GPI device is inadvertently disconnected, causing SpotOn to poll for a non-existent 'joystick'.

As an alternative to using two leads the 2 x 100K resistors could be mounted directly on the GPI card connector pins inside the computer, this should only be attempted by those with suitable experience.

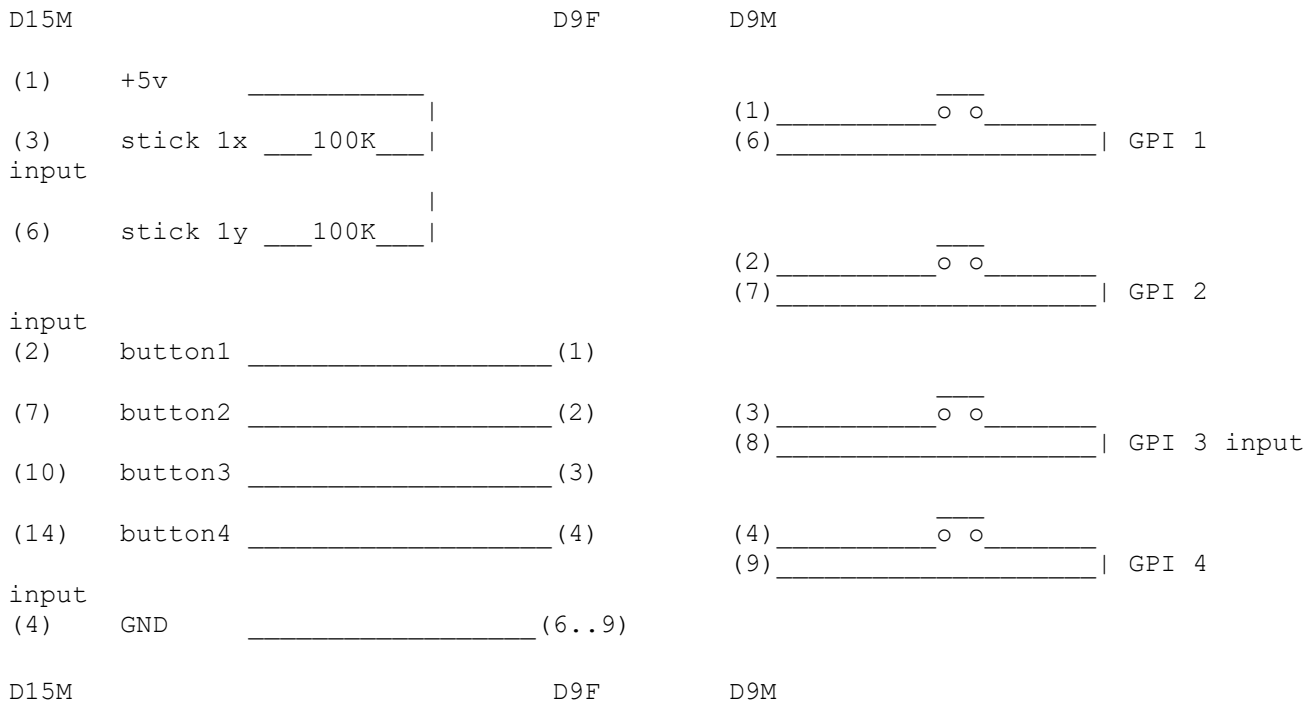

It is recommended that some form of protection is applied to the sound card inputs an Opto or Relay isolated interface would be suitable.

Alternatively a USB joystick can be used to provide the GPI inputs, in this case slightly more work will be required to extract the button signals from the joystick, but the internal wiring of such devices is usually simple.

## Midi

Game ports on many computers support Midi In/Out, the signals on the 15 way game port connector are not suitable for direct connection to a Midi device.

The diagram below from the [Midi Manufacturers Association](http://www.midi-makers.org/) shows one interfacing method

**Computer Sound Card Game Port to Standard MIDI Connector**

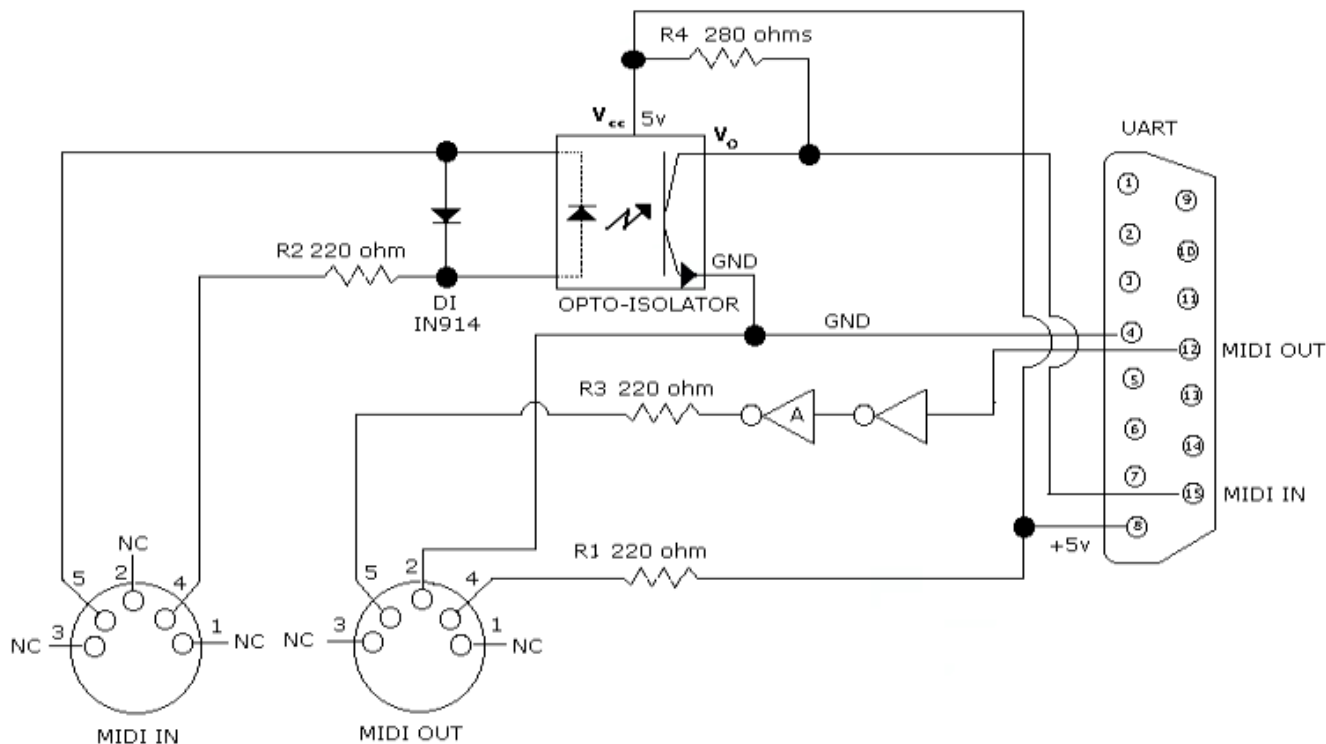

# GPI to Midi Convertor

Game port connectors (D15 way) are becoming increasingly rare on modern computers, there are a few alternatives available to pass GPI signals into SpotOn.

One method is to convert the GPI signal (contact closure) to a Midi note and set SpotOn to trigger from that note.

A unit made in the UK by Kenton Electronics [www.kenton.co.uk](http://www.kenton.co.uk) accepts 16 GPI inputs and patches these to 16 different Midi notes.



The GPIM-16 converter has 16 GPI (general purpose interface) inputs arranged on two 9 pin D sockets.

Each block of 8 inputs can be assigned a starting MIDI note number and subsequent inputs follow on consecutive note numbers. (default for first block is 36-43, and for the second block is 44-51).

Each block of 8 inputs can be set whether note offs are sent when the switches open (default yes).

The MIDI transmit channel for all inputs can be set (range 1 to 16, default 1).

The debounce value for all switch inputs can be set (range 1 to 100 milliseconds – default 10mS).

The inputs are arranged with internal pullups, so that shorting that input to ground will send the appropriate MIDI note-on message – releasing the short to ground will send a note-off message (unless disabled).

The GPIM-16 has two MIDI out sockets which both carry identical MIDI information. MIDI arriving at the MIDI input is merged with the data generated by the switch inputs and sent to the MIDI outs.

Editing of parameters is achieved by use of push buttons in conjunction with the LED display.

In order that settings cannot be accidentally changed, edit mode has to be enabled using a recessed push button.

# Package Converter

As SpotOn evolves there sometimes changes made to the file structure of the Packages, which makes the newer packages incompatible with older versions of SpotOn, Package Converter can overcome this problem by modifying the package file structure.

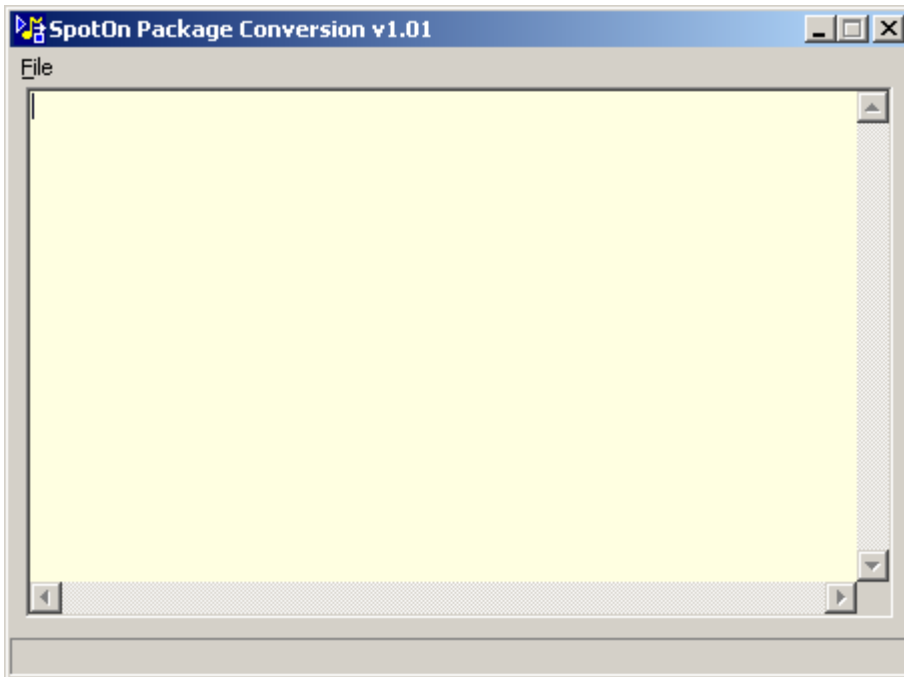

Select File|Open Package

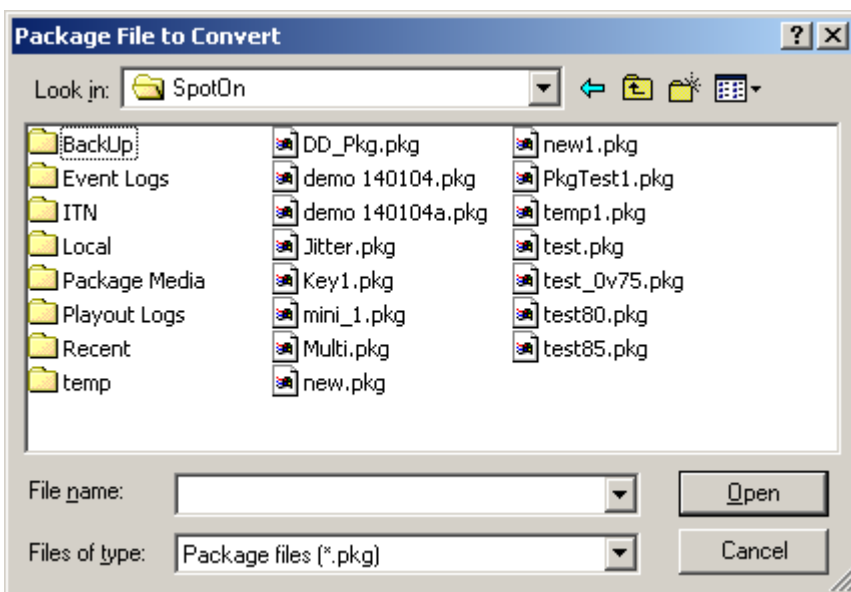
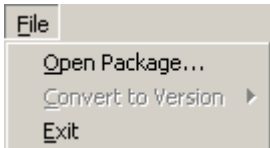

Choose the package to be converted

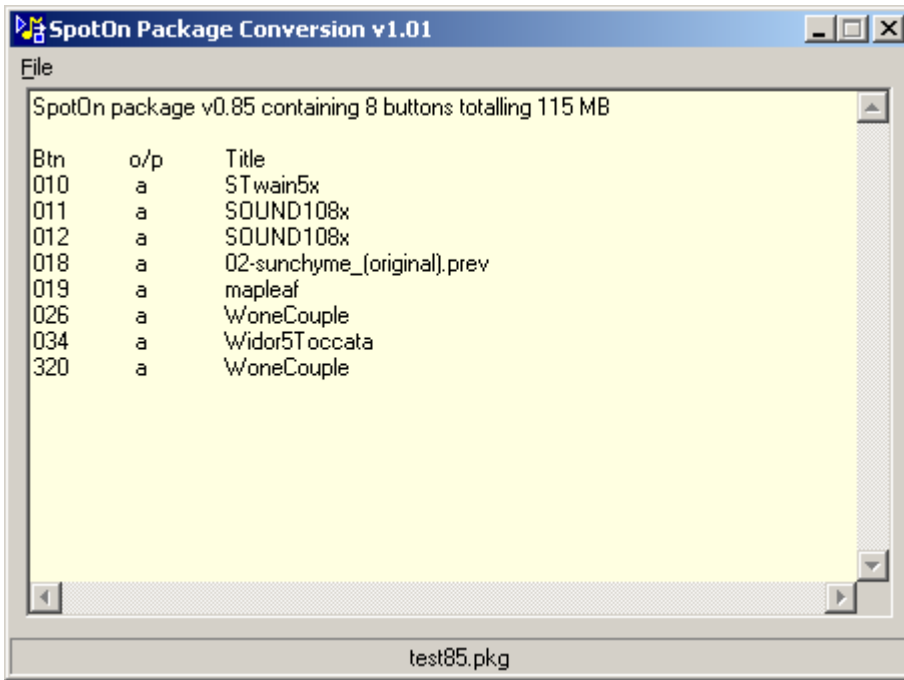

The program will list the contents of the package along with the version number of SpotOn that made the package, in this case it was v0.85

Select the version number to convert to

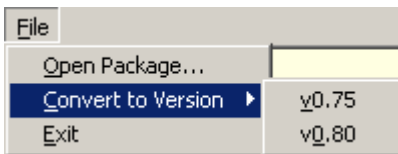

Enter the location and name for the converted package, which can be the same as the original so saving time and disc space

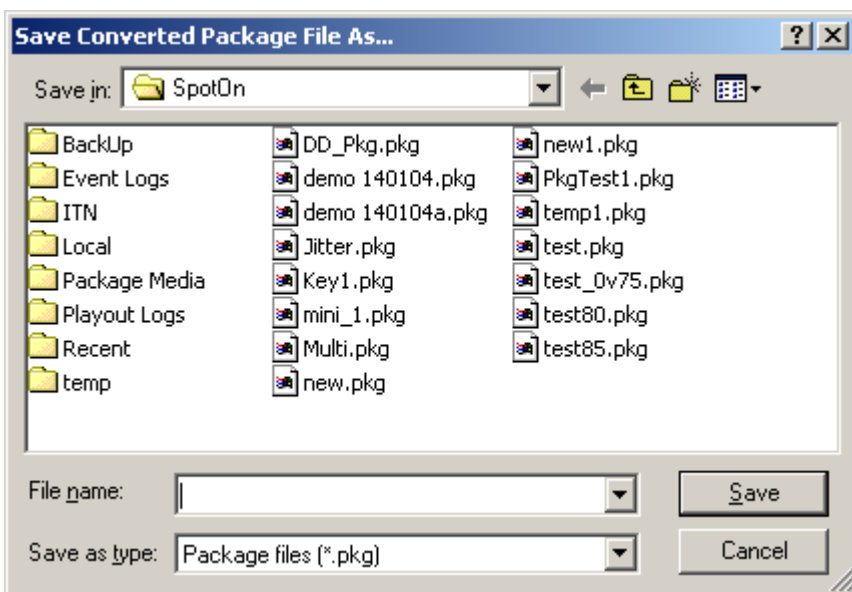

A progress window shows the number of files converted

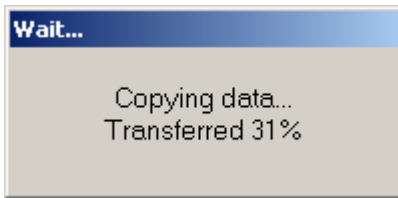

When the conversion process is complete, a summary is displayed in the status bar



# Package Extractor

SpotOn packages contain both button property information and audio data, sometimes it may be necessary to extract the audio data from a package for analysis or archiving.

A utility called UnPackageWAVs.exe is supplied and will be found in the Program Files\Serialtech\SpotOn folder, running the file will show the following dialog boxes.

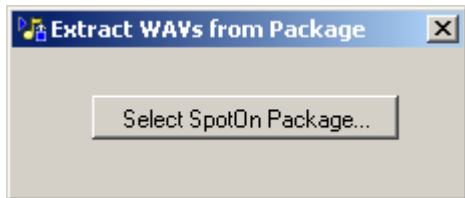

Click on Select Package and navigate to the location of the package to be extracted

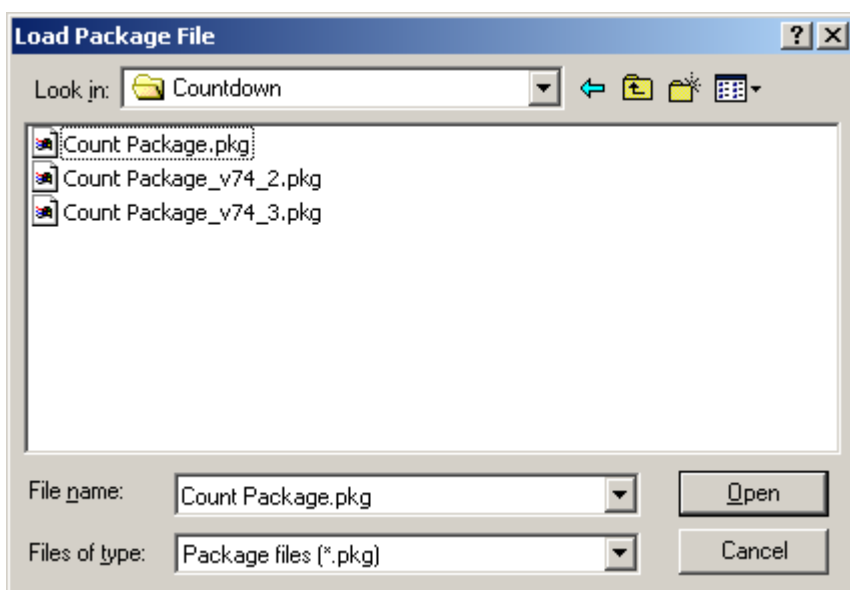

Once the package has been selected the next options are:-

- a, Extract a list of tracks contained in the package
- b, Extract the original unmodified WAV files with track list
- c, Extract the original WAV files using the gain, fade and trim

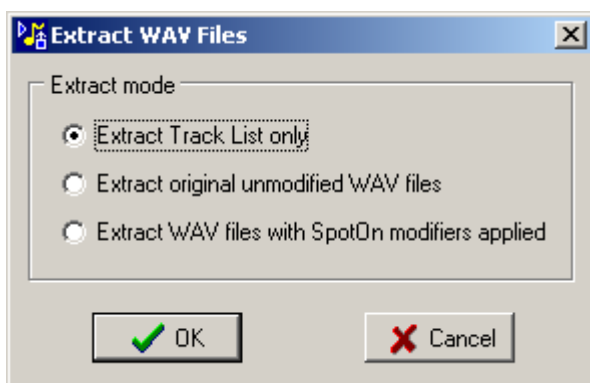

The tracks will be extracted from the package and the selected modifiers applied, the extracted audio files will be saved with new names. Audio files that were originally mono are converted to stereo.

A track named 'test1' on button 1 with no modifiers applied will be saved as:-

'001\_test.wav'

A track named 'test1' on button 1 with modifiers applied will be saved as:-

'001\_test\_Mod.wav'

The three digit prefix refers to the button number so '023\_sample\_Mod.wav' would be the track from button 23.

Next the destination folder for the extracted WAV files and track list is assigned

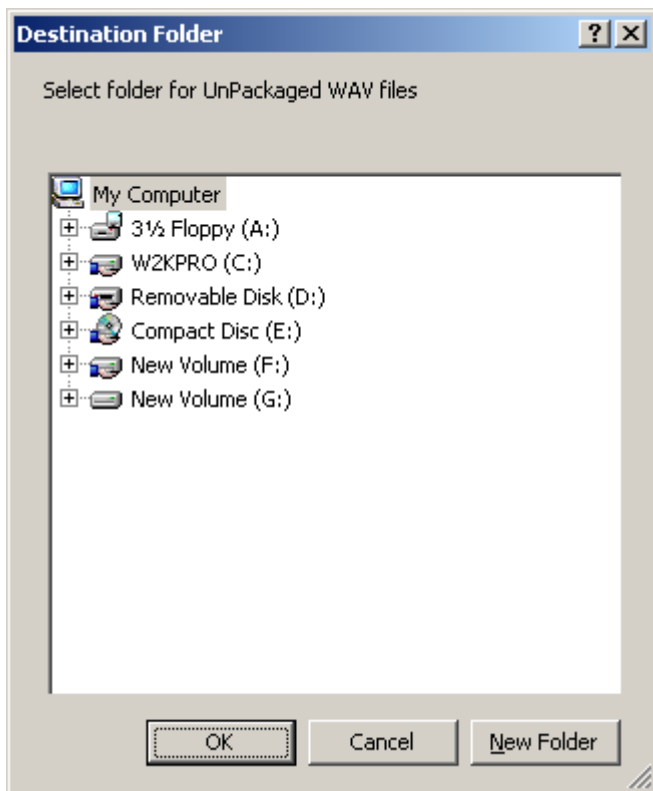

and finally after the files have been extracted the initial window is redisplayed showing the version number of SpotOn that created the package.

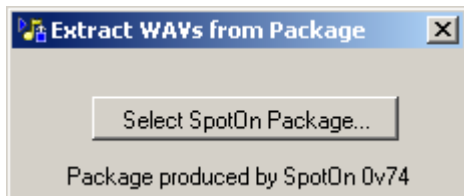

# Session Analyser

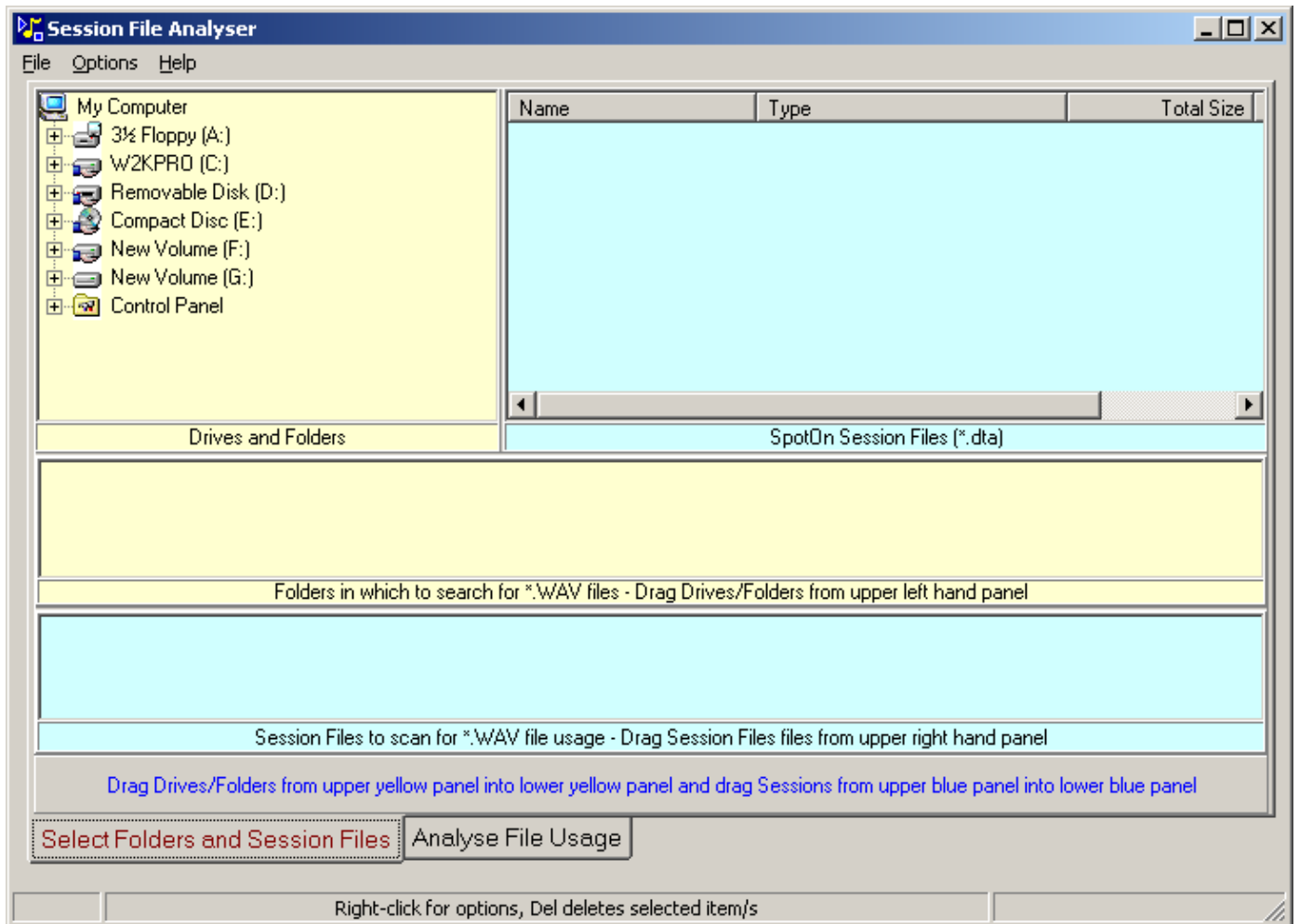

Session Analyser allows comparisons to be made between the files contained in a specified selection of disc folders and those referenced by SpotOn sessions.

The purpose of this comparison is to identify those audio files present on the disc that are not referenced by any of the selected session files, and allow the files to be moved to a new location pending deletion.

The action of moving files is only enabled when SpotOn is running in [Administrator](#) mode

## Disc Folders

The first page named 'Select Folders and Session Files' allows the disc search range to be specified, by identifying drives and/ or individual folders.

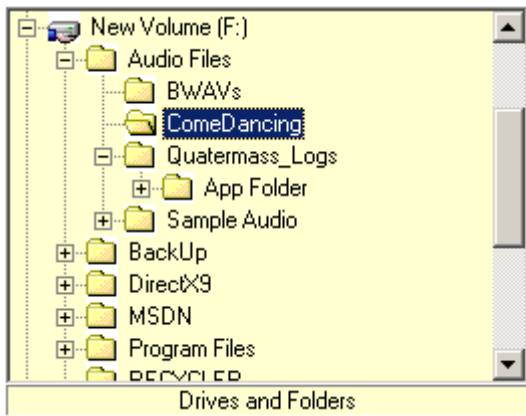

In the upper left hand panel a folder can be selected and then dragged down to the lower search panel, items can only be dragged between panels of the same colour.

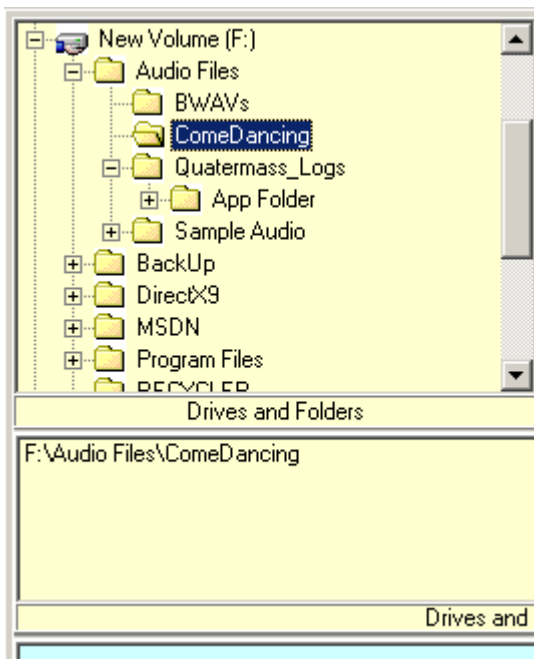

Similarly whole drives can be dragged into the search list

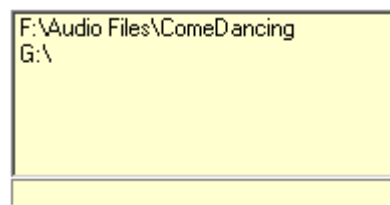
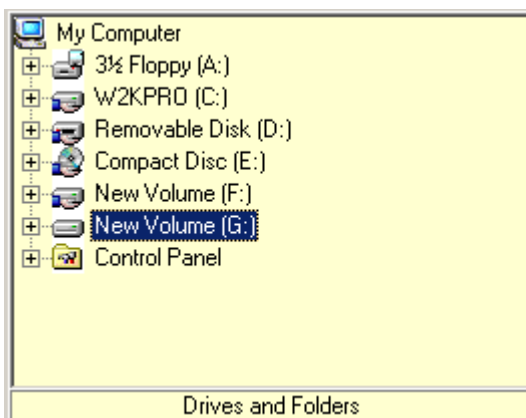

Entries in the list can be deleted by right-clicking in the list and selecting the appropriate option, the delete key will also remove the selected items

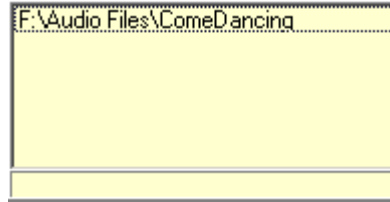
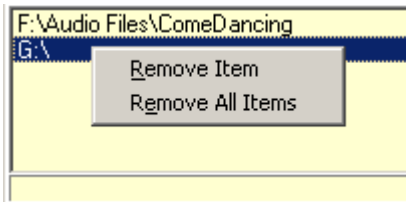

Here the G:/ entry has been removed

It is possible to include ambiguous entries in the search list, below the search of drive F:/ would include the folder F:/Audio Files/Come Dancing, so the second entry is redundant, the program filters out such situations during the analysis

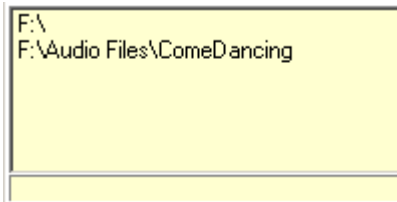

### Session Files

Session files are selected in a similar manner to the disc folders, they are filtered out from the selected folder and will appear in the upper right hand panel.

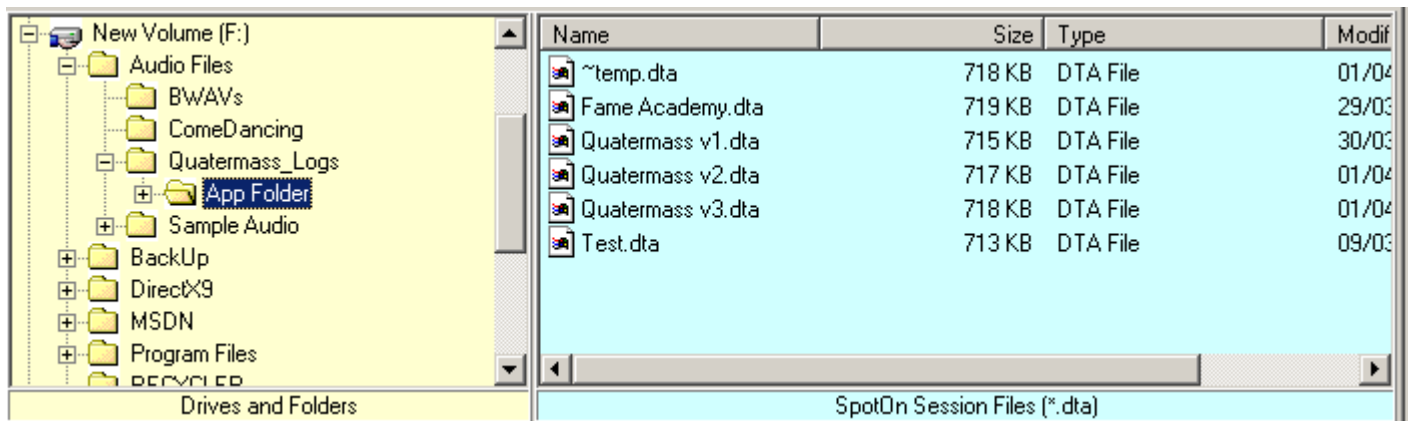

Using the Windows file selection options highlight the session files to be used in the analysis

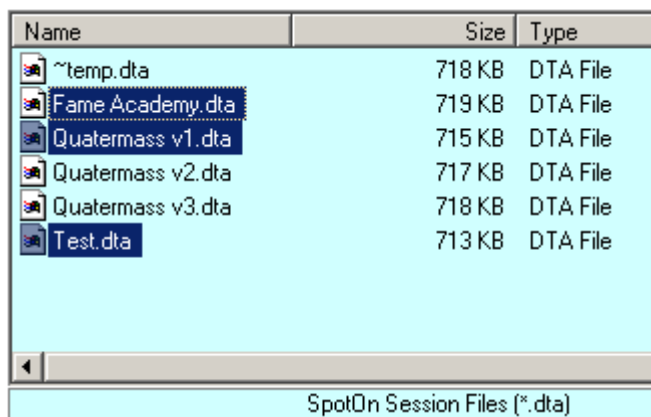

Drag the selection to the lower panel

F:\Audio Files\Quatermass_Logs\App Folder\Fame Academy.dta F:\Audio Files\Quatermass_Logs\App Folder\Quatermass v1.dta F:\Audio Files\Quatermass_Logs\App Folder\Test.dta
Session Files to be included in Analysis

## Analysis

Having completed the above steps the data is ready for analysis, select the second page 'Analyse File Usage'.

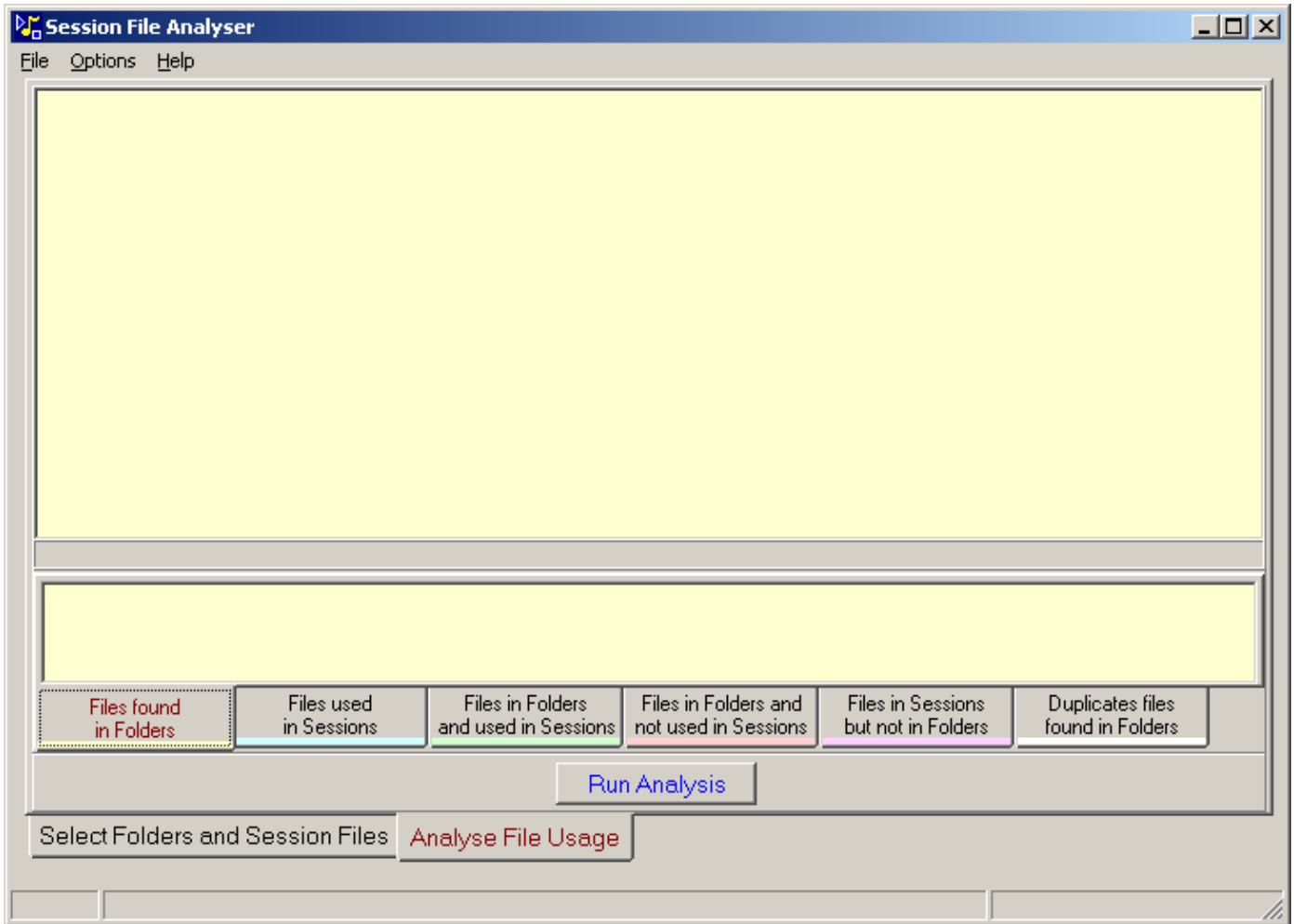

Click on the Run Analysis button to start the process, a progress box will appear showing how many files have been found versus files scanned.

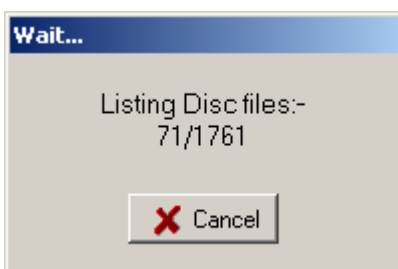

When the scan is complete, the results are loaded into the upper panel

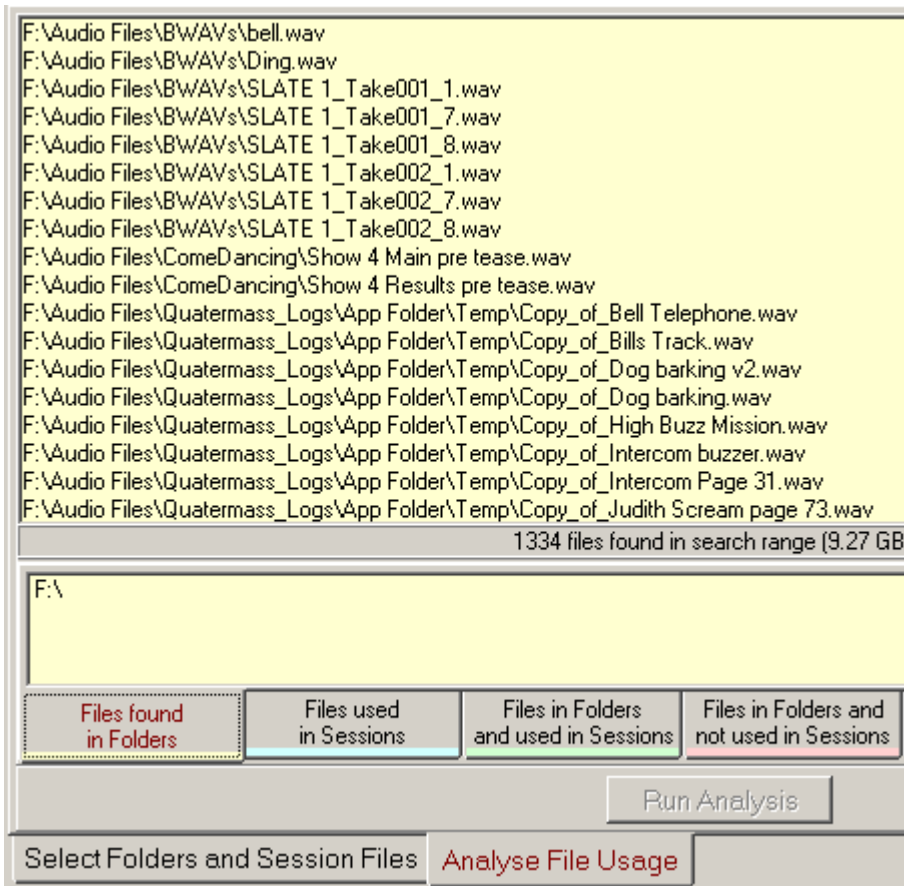

The 6 tabs under the results panel select the various sections:-

- |                              |   |
|------------------------------|---|
| a, Files found in Folders    | All *.WAV files found in the search path                                |
| b, Files used in Sessions    | All *.WAV files referenced by the Session file/s                        |
| c, Files in Folders and used | Files contained in both (a) and (b)                                     |
| d, Files in Folders and not  | Files in (a) but not in (b)   |
| e, Files in Sessions but not | Files in (b) but not in (a)   |
| f, Duplicate files found in  | Files that have the same names and sizes that appear in the search path |

The 4th tab is the one used to move files, select the files and right-click the selection

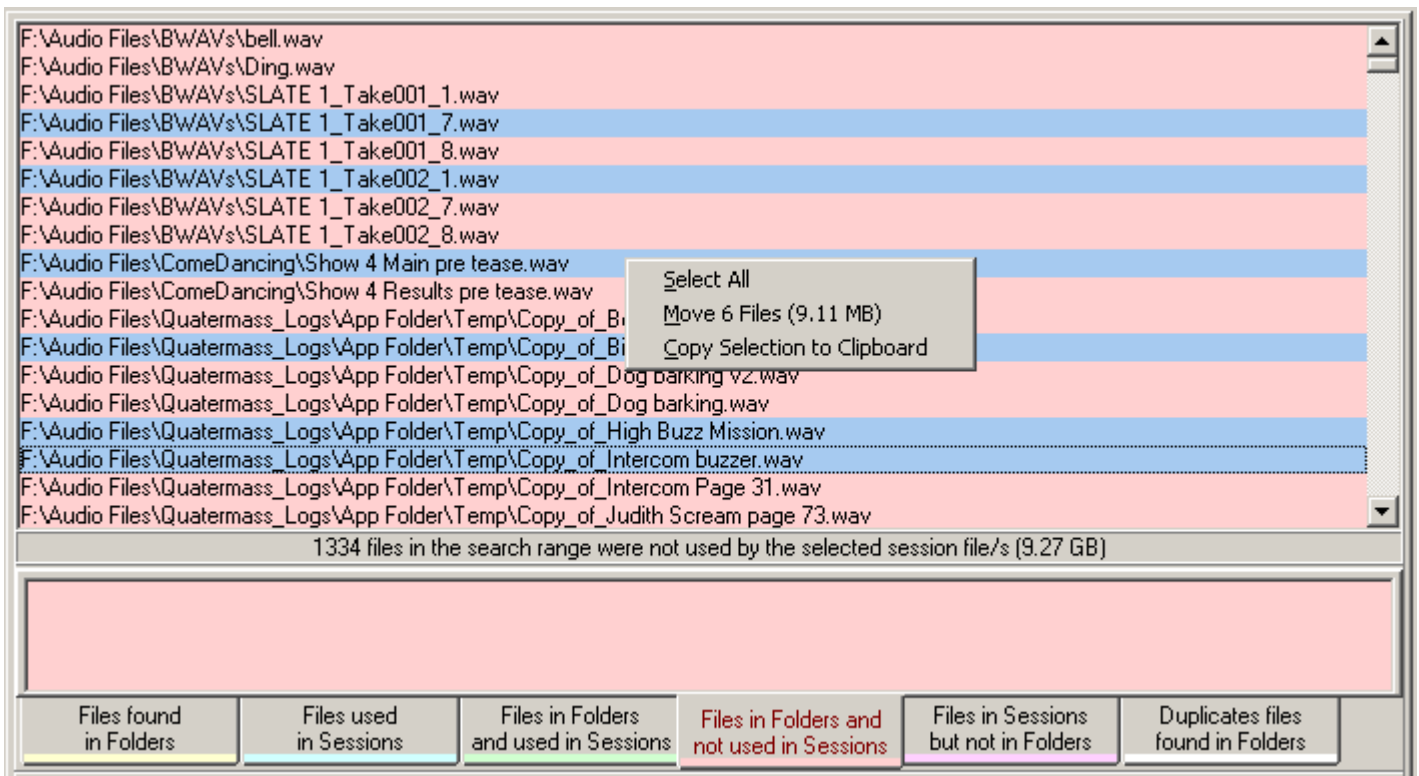

From the popup menu choose the Move xx Files option, which will display a Folder selection dialog to select the destination for the moved files.

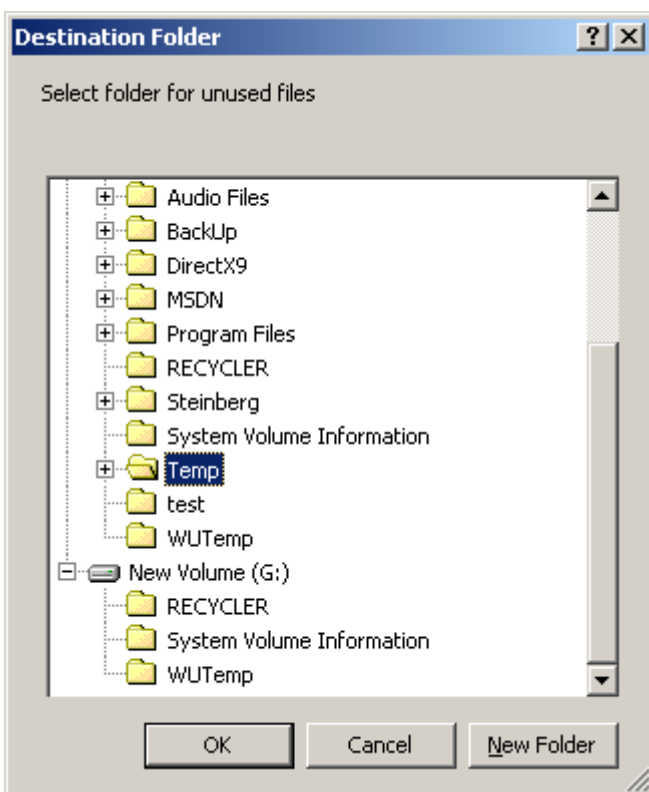

After selecting the destination folder and clicking OK, a further confirmation dialog will appear.

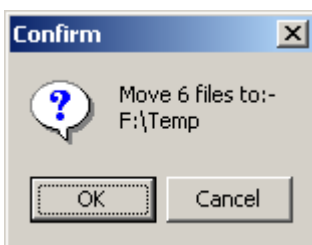

Followed by a progress window indicating the number of files moved

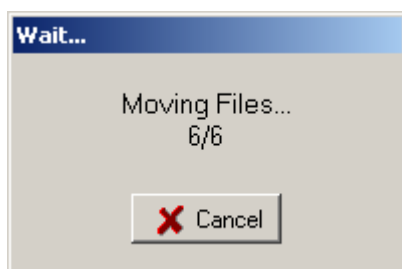

The final tab 'Duplicates', lists files in the search range that have the same name and file size.

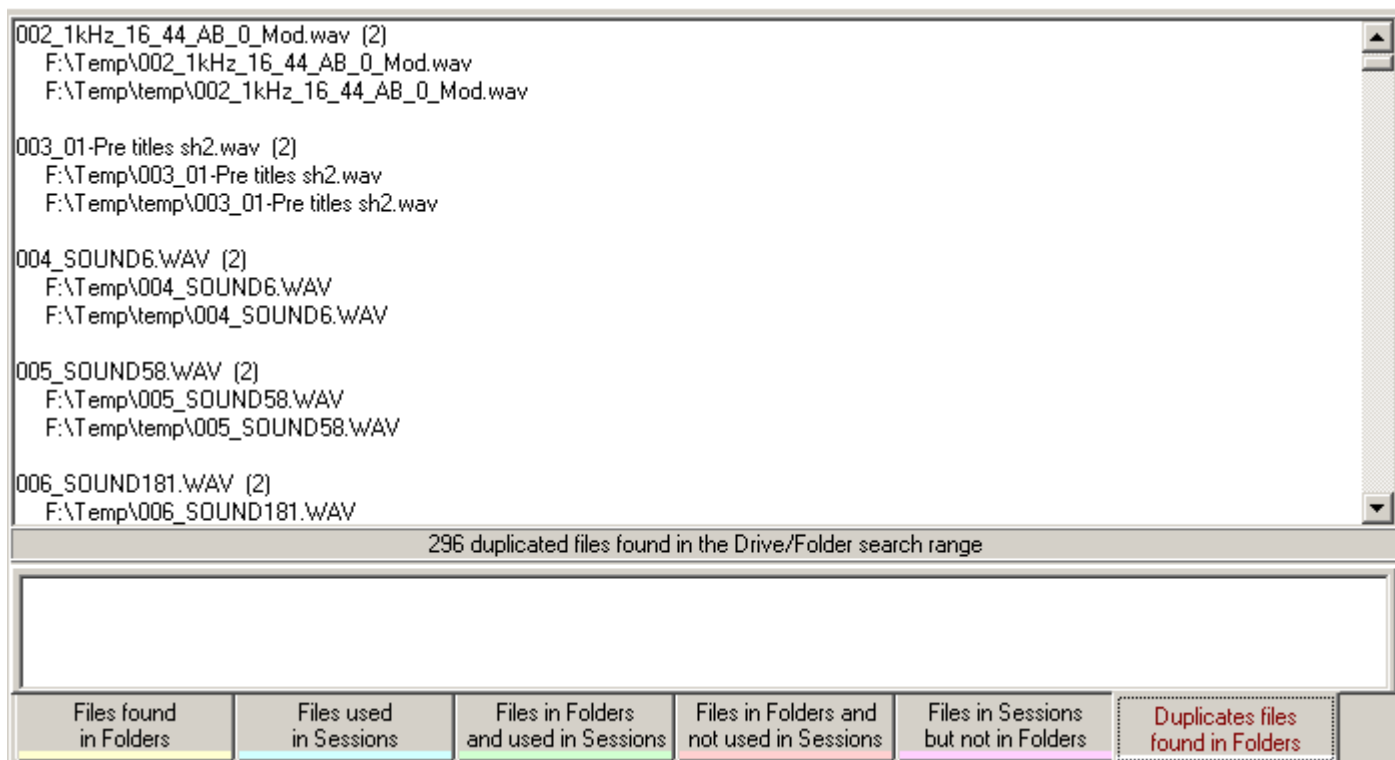

The results shown on the second tab 'Files Used in Sessions' may have some files drawn in red text as below

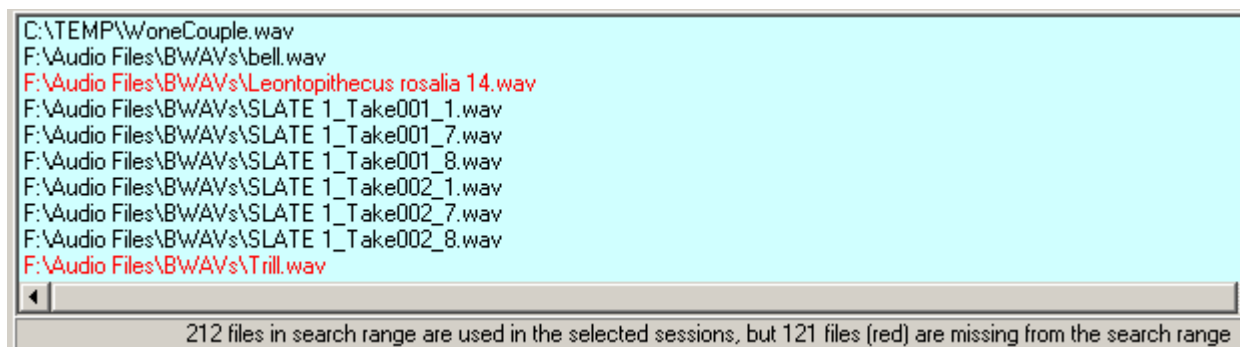

The files drawn in red text are those that cannot be found in the drive/folder search path because they have been moved, renamed or deleted.

The filenames indicate they should be found in the search path but are not present. These files would be listed as not found if this session containing the files was loaded into SpotOn.

The right-click popup menu on this tab has an option to List References, this will list in the lower panel all the selected session files that use this file.

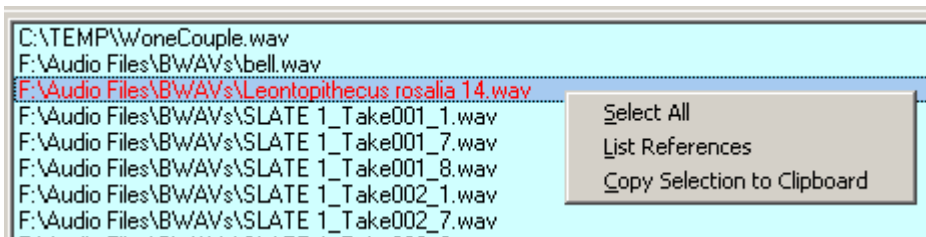

In this case the file is only used in one session 'multichan.dta'

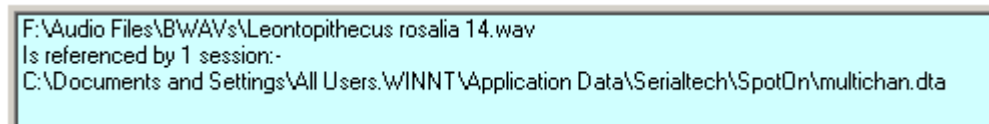

If more than one session uses the file then they are listed as below

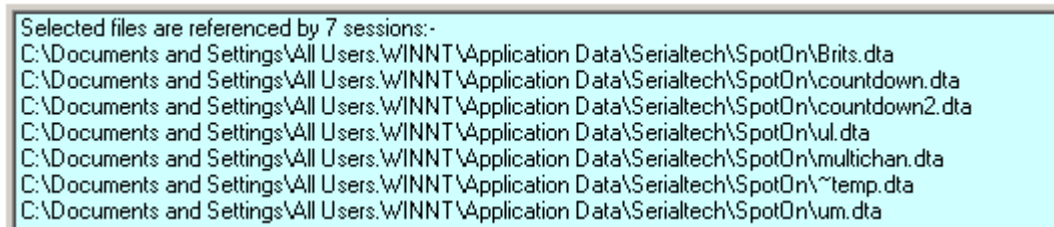

## Menus

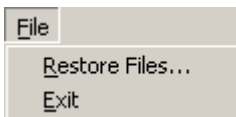

The file menu contains a Restore option, which allows files moved by the process described above to be returned to their original locations.

The moved files are recorded in \*.saf files named with the date and time that the files were moved

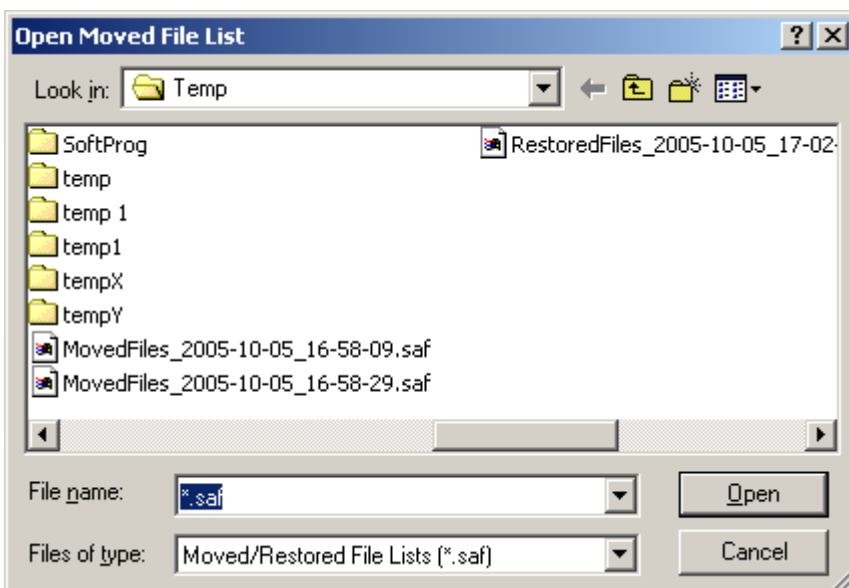

Locate the \*.saf file that refers to the files to be restored and click on Open, a confirmation dialog will appear showing the number of files involved.

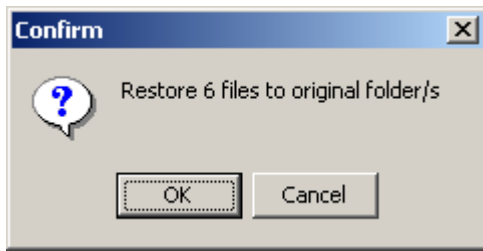

The options menu allows the popup hints to be switched on/off, and to show or hide the coloured bars on the results page buttons

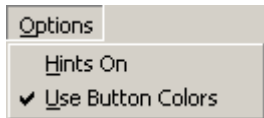

Button Colors On



Button Colors Off



# SpotOnSearch

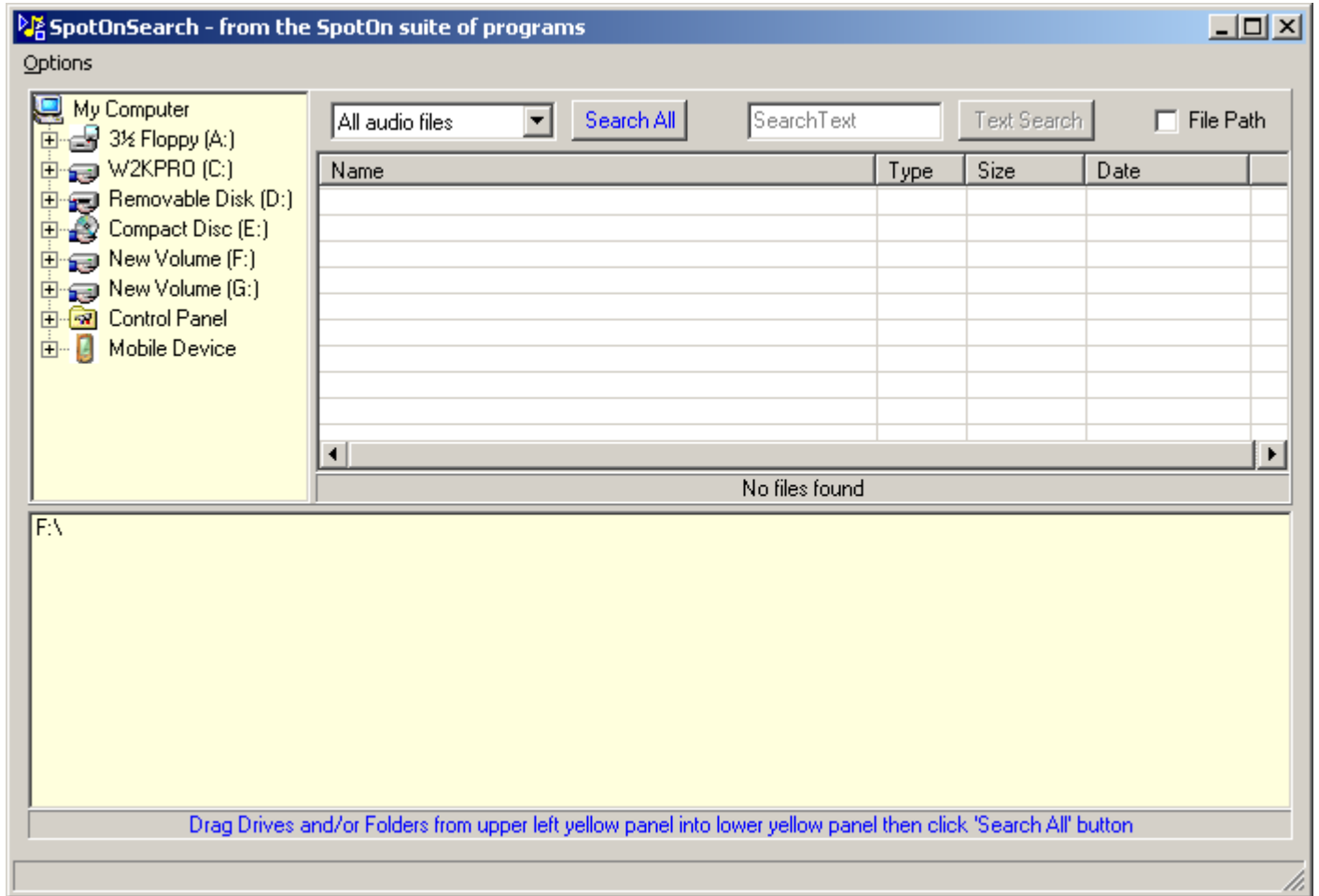

SpotOnSearch is a standalone utility to aid searching of discs for a variety of file types, the search range is specified by discs and/or folders, these can be selected in the upper left yellow panel and then drag and dropped in to the lower yellow panel as required.

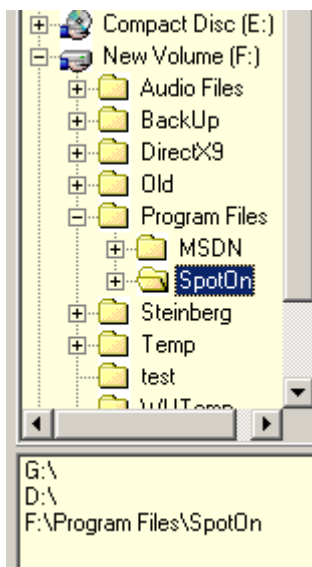

Items can be removed from the search range by using the right-click popup menu or pressing the delete key when an item is highlighted

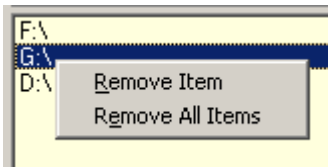

When the search range is changed the 'Search All' button is enabled.

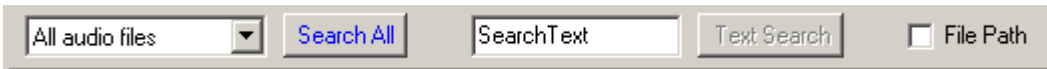

The Search All operation can list a specific file type and this is selected from the drop down list

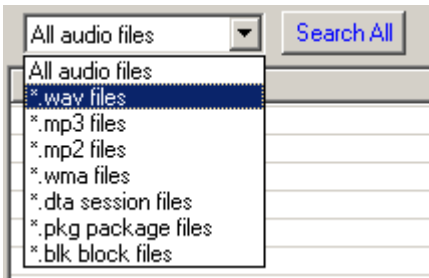

Clicking the 'Search All' button starts a scan of all the selected disc paths, a progress box shows the number of files of the required type found vs the number of files scanned

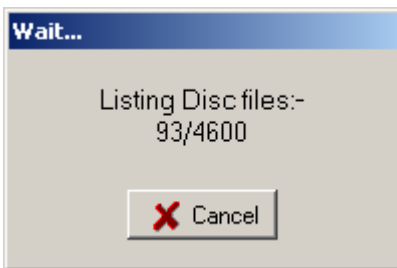

On completion of the scan the files will be listed, the order of the files can be changed by clicking the column headers, below the results are shown with descending file size

Name	Type	Size >	Date
STwain5xy_32x96	.wav	218 MB	14/11/05 20:56
034_Widor5Toccata_Mod	.wav	62.6 MB	26/09/05 17:44
Widor5Toccata	.wav	62.6 MB	05/06/05 09:07
Widor5Toccata	.wav	62.6 MB	30/10/05 10:32
Widor5Toccata	.wav	62.6 MB	22/09/05 07:14
Widor5Toccata	.wav	62.6 MB	22/09/05 07:41

Checking the 'File Path' box displays the full file path (truncated to fit the column size)

Name	Type	Size >	Date
F:\...\SpotOn\Package Media\test85\STwain5xy_32x96	.wav	218 MB	14/11/05 20:56
F:\...\Package Media\DD_Pkg75\034_Widor5Toccata_Mod	.wav	62.6 MB	26/09/05 17:44
F:\Program Files\SpotOn\Local\Widor5Toccata	.wav	62.6 MB	05/06/05 09:07
F:\...\SpotOn\Package Media\test85\Widor5Toccata	.wav	62.6 MB	30/10/05 10:32
F:\Program Files\SpotOn\temp\Widor5Toccata	.wav	62.6 MB	22/09/05 07:14
F:\Temp\Widor5Toccata	.wav	62.6 MB	22/09/05 07:41

Alternate clicks on the column headers sorts the results in ascending/descending order, below the Size column header has been clicked and the results are now sorted by ascending file size

Name	Type	Size <	Date
005_SOUND58	.wav	3.41 KB	12/02/05 22:03
005_SOUND58	.wav	3.41 KB	12/02/05 21:56
006_SOUND58	.wav	3.41 KB	12/02/05 21:14
013_SOUND58	.wav	3.41 KB	20/02/05 12:26
SOUND58	.wav	3.41 KB	20/02/05 12:26
SOUND58	.wav	3.41 KB	12/02/05 21:00
004_SOUND6	.wav	4.38 KB	12/02/05 22:03

The text search box allows for a word to be found within the filename (the file path is excluded from the text search), clicking the Text Search button re-orders the list

Name	Type	Size	Date
bell	.wav	805 KB	12/08/04 19:22
bell	.wav	805 KB	08/01/05 23:05
door bell	.wav	464 KB	10/01/05 18:58
door bell	.wav	464 KB	17/02/05 13:07
door bell	.wav	464 KB	12/01/05 10:14
door bell	.wav	464 KB	20/02/05 12:26
door bell	.wav	464 KB	13/02/05 07:09
Door Bell Bing Bong	.wav	1.02 MB	07/08/05 15:47

Single file or multiple files can be selected with the usual Ctrl/Shift modifiers, the selection can then be drag and dropped onto a SpotOn button where they will be loaded onto consecutive buttons.

Name <	Type	Size	Date
076_Points of View Sting	.wav	719 KB	20/02/05 11:32
077_Pussy cat pussy cat	.wav	7.89 MB	20/02/05 11:32
078_Scary Dick yorkshire KPM_57_31_44khz	.wav	8.52 MB	20/02/05 11:32
079_Scary Dick	.wav	1.44 MB	20/02/05 11:32
08-AudioTrack 08	.wav	9.92 MB	03/02/04 22:05
08-AudioTrack 08	.wav	9.92 MB	04/02/04 09:05
08-AudioTrack 08	.wav	9.92 MB	10/11/04 14:46
080_Scoreboard END	.wav	392 KB	20/02/05 11:32
081_Scoreboard LOOP series 2	.wav	1.41 MB	20/02/05 11:32
082_Scoreboard RESTART	.wav	1.77 MB	20/02/05 11:32
083_Shove it In Yer Gob Guide Vox	.wav	11.4 MB	20/02/05 11:32
084_Shove it In Yer Gob Inst	.wav	11.2 MB	20/02/05 11:32
085_Showbiz AACD6 tk 5 - Early Riser	.wav	32.6 MB	20/02/05 11:32
086_Punch with Oof	.wav	66.4 KB	20/02/05 11:34
087_Plonk metallic_Mod	.wav	136 KB	20/02/05 11:34

1712 files (11.6 GB) - Select file/s and Drag+Drop onto SpotOn - 5 files selected (21.0 MB)

SpotOnSearch has the facility to copy one or more files to a new location, shift+right-clicking on a highlighted file will display a popup menu

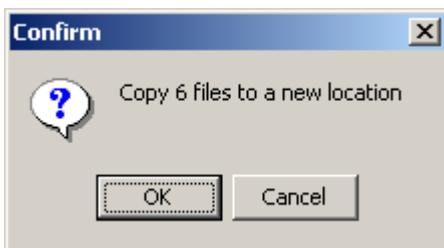
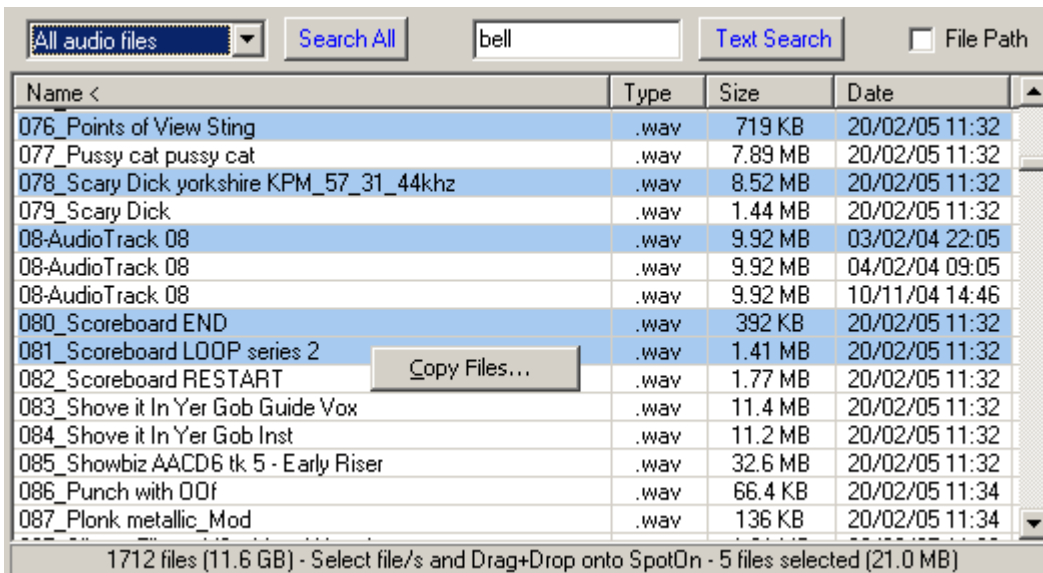

Clicking OK will offer a destination folder selection dialog, the default location will be that used by SpotOn to load WAV files.

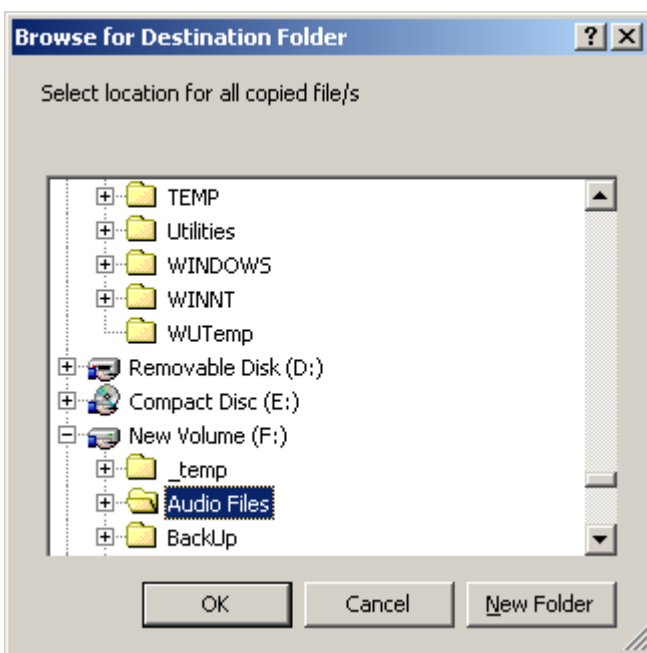

The OK button will bring up a further confirmation prompt box

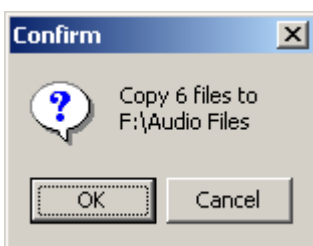

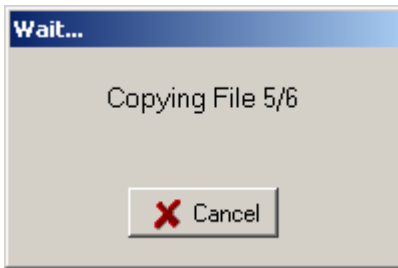

If a file being copied already exists in the destination folder the dialog below will be shown allowing the files to be selectively copied.

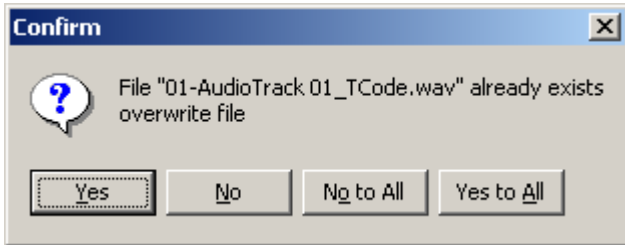

## Options

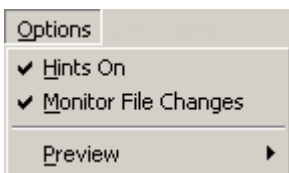

HintsOn allows the popup hints to be enabled/disabled

Monitor File Changes enables a background check of changes to files in the range of folders selected, creation, deletion and renaming of files and folders will be detected and the search list updated.

Preview selects the method of track preview - either SpotOn, Microsoft Windows Media Player or none.

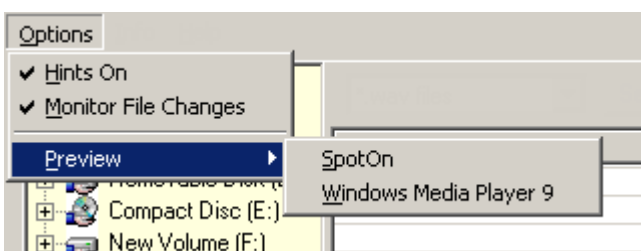

Preview Track -SpotOn

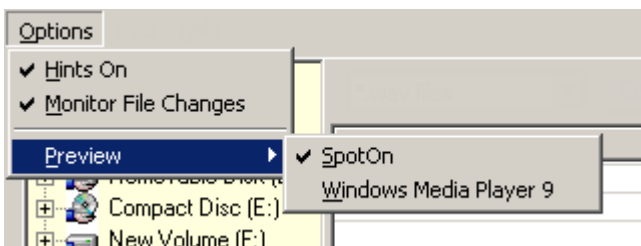

If SpotOnSearch was launched from the SpotOn file menu and SpotOn is selected as the preview destination, then the tracks can be previewed individually by double-clicking WAV files in the results list. So for example the entries for 'bell' and 'door bell' can be compared by double-clicking the names, right-clicking will stop the track as will closing the SpotOnSearch utility.

Name	Type	Size	Date
bell	.wav	805 KB	12/08/04 19:22
bell	.wav	805 KB	08/01/05 23:05
door bell	.wav	464 KB	10/01/05 18:58
door bell	.wav	464 KB	17/02/05 13:07
door bell	.wav	464 KB	12/01/05 10:14
door bell	.wav	464 KB	20/02/05 12:26
door bell	.wav	464 KB	13/02/05 07:09
Door Bell Bing Bong	.wav	1.02 MB	07/08/05 15:47

The previewed audio will be played out by SpotOn to the output that was selected as being the 'Preview Output' via Global|[Preview Output Assignment](#).

### Preview Track - Windows Media Player

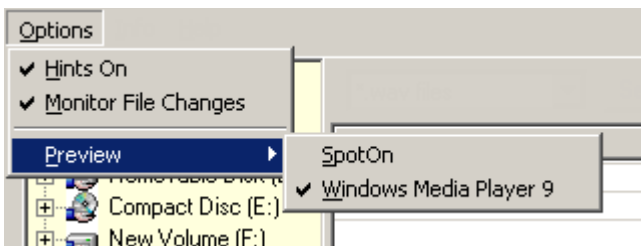

If the Windows Media Player (WMP) option was selected then the tracks can be previewed individually by double-clicking files in the results list. An embedded WMP appears at the bottom of the main window

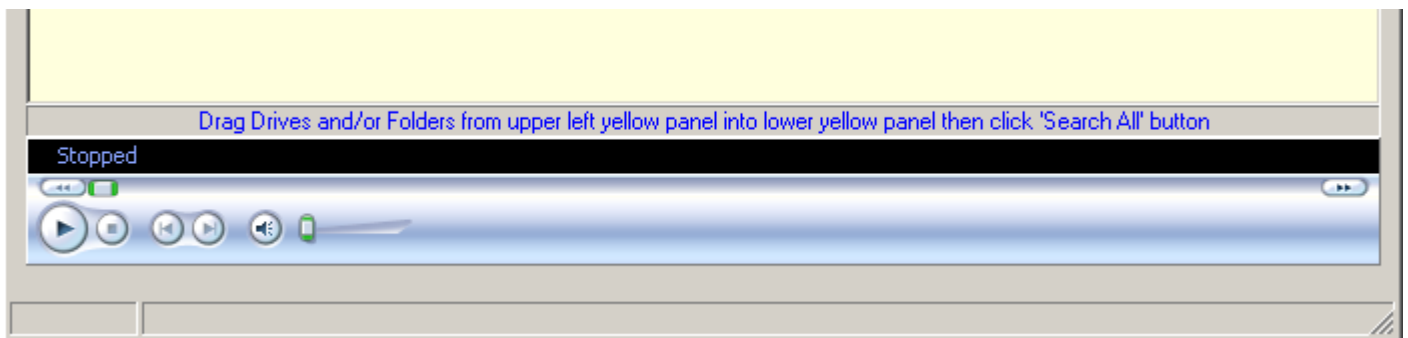

So for example the entries for 'bell' and 'door bell' can be compared by double-clicking the names, right-clicking will stop the track as will closing the SpotOnSearch utility or deselecting WMP as the preview option.

Name	Type	Size	Date
bell	.wav	805 KB	12/08/04 19:22
bell	.wav	805 KB	08/01/05 23:05
door bell	.wav	464 KB	10/01/05 18:58
door bell	.wav	464 KB	17/02/05 13:07
door bell	.wav	464 KB	12/01/05 10:14
door bell	.wav	464 KB	20/02/05 12:26
door bell	.wav	464 KB	13/02/05 07:09
Door Bell Bing Bong	.wav	1.02 MB	07/08/05 15:47

The previewed audio will be played out by WMP to the output that was selected via WMP menu Tools|Options|Devices|Speakers|Properties

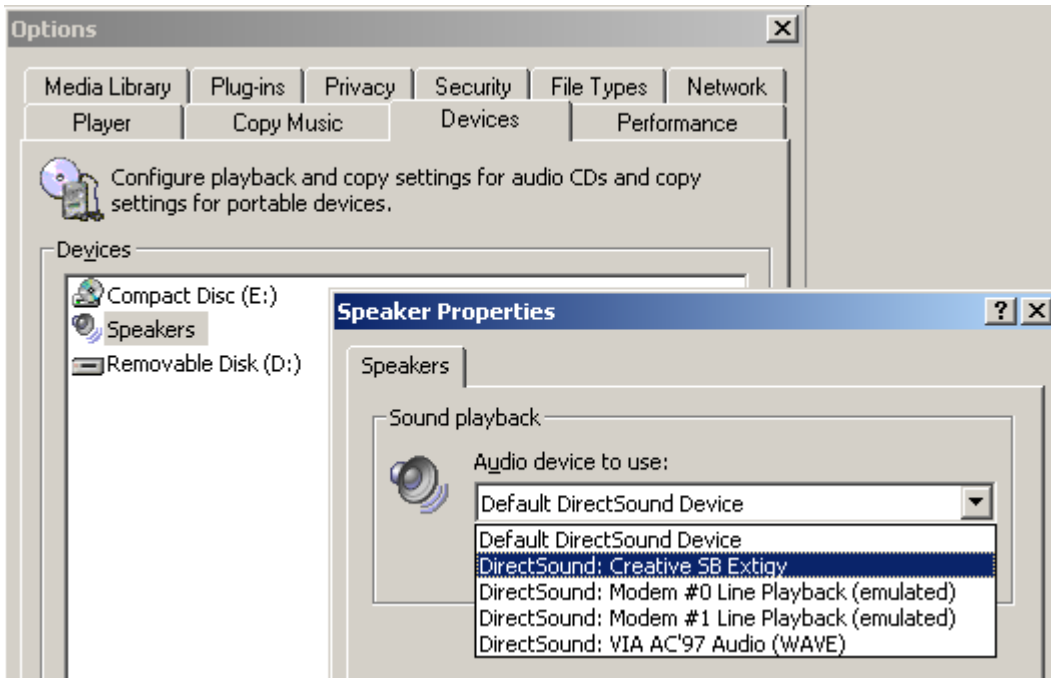

**Info**

The Info menu Item shows the last 1000 changes made to any files in the search paths irrespective of file type.

The image shows a 'Log of Recent File Changes' window with a table of file operations. The table has four columns: Time, Action, Path1, and Path2. The data is as follows:

Time	Action	Path1	Path2
10:42:22	Renameltem	F:\Sting_441.wav	F:\Sting2_441.wav
10:43:10	Renameltem	F:\Sting2_441.wav	F:\Sting3_441.wav
10:43:15	Renameltem	F:\Sting3_441.wav	F:\Sting4_441.wav
10:43:19	Renameltem	F:\Sting4_441.wav	F:\Sting_441.wav
10:43:53	Renameltem	F:\Sting_441.wav	F:\New Folder\Sting_441.wav
10:44:05	Renameltem	F:\New Folder\Sting_441.wav	F:\New Folder\Sting2_441.wav
10:44:22	Create	F:\New Folder\New Folder\Sting2_441.wav	
10:44:32	Delete	F:\New Folder\New Folder\Sting2_441.wav	

In the above example the file F:\Sting\_441.wav has been renamed three times ending with Sting4\_441.wav then set back to the original name.

The file is then moved to F:\New Folder and renamed to Sting2\_441.wav

Finally the file F:\New Folder\Sting2\_441.wav is copied to F:\New Folder\New Folder\ and then the copy deleted.

A log of the 1000 most recent changes is saved to disc when SpotOnSearch is closed.

# Versions

Major releases shown in bold

- v996 24/1/2026  
EmBER+ control option added
- 06/03/2025  
Plain text UDP commands added
- 31/10/2024  
Fixed Midi note assignment being lost on change of Audio Settings
- 21/09/2023  
Adjustment to handle multiple monitors or different resolutions
- v995 25/02/2023  
Added Win 10/11 detection
- 29/11/2022  
OSC listens on UDP port 4700  
OSC Tx messages added to OSC log window
- 16/08/2022  
Slave In Point added to cue up calculation, previously slave cue was always relative to start of track ignoring any Trim In points
- 09/07/2021  
OSC commands audio/button/xy x=button number, y=stop/play  
OSC listens on UDP port 7000
- v993 08/06/2021  
When using Shift+Ctrl+right-click to change output assignment mono/phase selection was lost, added to Save/Restore Params  
Preview track not working in 5.1 mode due to wrong channel mask  
High DPI fix on Drag/Drop links and initial Splash screen  
Ctrl+R defaulting to Embedded tracknames even when TrackNames had been changed  
Trap for Dante Virtual Sound Card installed but not running  
M4a decoder added via BASS\_ALAC and BASS\_AAC dlls  
DanteCheck removed from command line added to Output Device Assign popup and ini file  
Auto convert Mono to Stereo on load option added A=B=(M-6dB)  
DanteCheck checkbox enabled by Dante Virtual Soundcard installed  
HighDPI range extended 100%..300% as user setup requires 250%  
LawoCheck added similar to Dante  
UDP commands extended to include filenames and countdown time for SpotOn\_SD  
OSC commands audio/button/xy x=button number, y=stop/play  
OSC listens on UDP port 7000
- 08/02/2021  
Fixed loss of M/S links when changing o/p from right-click Group/Output popup.
- 05/06/2020  
LawoCheck added similar to Dante

30/05/2020

DanteCheck checkbox enabled by Dante Virtual Soundcard installed  
HighDPI range extended 100%..300%

v991 01/10/17

Ctrl+I for Click Track menu shortcut

Ctrl+J for popup Timecode display menu shortcut

swap region not taking master/slave settings fixed

Ctrl+J changed to popup Timecode generator

delete source file option was not setting checked parameter on menu item

Triggering of Midi Out on a slave button firing instantly and also after Play Delay

Layout extended to allow 20 columns

Midi control of TxMode On/Off added

v990 29/09/2016

Button Layout wrap option added

**v0.989** 27/09/2016

AllStop mods introduced in v986 removed as they cause triggering of Play Next when tracks stopped

List parameter \$30 lists button names plus attributes.

v0.988 15/01/2016

Changes for interface to Tab version

v0.987 04/11/2015

TrimStart included in the equation to remove effect of master InPoint

v0.986 10/09/2015

Properties window Browse to folder changed to select file not just folder

v0.984 16/06/2015

File Folders 'My Network Places' not showing mapped drives,  
test on later than WinXP to show My Computer instead

v0.983 22/05/2015

Check added to optionally retain Network Slave settings when  
loading packages saved from Master computer

- v0.982 26/10/2014  
Source Port number added to UDP/TCP Play Cmd log entry when Delay time is zero  
Delay time embedded in message is now AND \$7fff
- v0.981 08/09/2014  
Include previous day's log option added to File Folders network  
playlist log selection works with Ctrl+P only
- v0.980** 24/04/2014  
MicroFade In/Out bug on 32 bit float fixed  
Mono tracks in 5.1 mode on Win7 fixed  
Midi Out on Play Delay options added to be Instant or After Delay in Eng|Misc
- v0.979 08/03/14  
Duplicate numbering fixed for 8 MADI groups  
Ctrl+W added to reset "Tracks Played" for last track played only
- v0.978 17/01/2014  
Global Properties and Output Device Assign lists widened
- v0.977 30/12/2013  
Save Network Log files Ctrl+P
- v0.976 25/11/2013  
Copy and Paste of Trim In/Out via global clipboard added under Render menu on Trim  
page
- v0.975 06/11/2013  
Locked Midi notes being copied when buttons swapped via clipboard
- v0.974 11/10/2013  
Playlist loop 9999 bug fixed - left over from attempting multiple loop exits  
TxMode log filter
- v0.973 03/09/2013  
MP3 ID3 tag Unicode fix  
FTP mode changed to Passive

- v0.972 23/08/2013  
Off screen Mouse Cursor error fixed
- v0.969 14/02/2013  
Option InPlaceConversion to save 24>32 bit conversions and decompressed files to source folder.  
Global Properties page 4 was checking all outputs on exit not just leaving those already checked.  
PBus bug message stack was mixing up 32+64 bit integer values
- v0.968 12/06/2012  
Copying buttons caused MidiNoteOut to be copied to MidiStopOut  
Master Slave link name dropdown causing error on number >100, limit extended to 255 on both lists
- v0.967 01/05/2012  
Accepts latest ProTools WAV format  
Bug in direct entry of [Trim In/Out](#) values fixed  
Provision to [extract CD tracks](#) direct to disc
- v0.963 01/02/2012  
Stop Slave triggers speed window slowdown to zero if [speed window](#) is open on stopping button  
ShowPlayedBtnsOn, ShowPlayedBtnsOff, ClearPlayedBtns added to [Network Master/Slave](#) control  
[Network Play](#) message was being sent when button Stopped so slave PC restarted button  
Panel Image and button colour copy using [Ctrl+Alt+Shift left drag](#)  
[Floating timecode](#) display window added  
[Play Delay](#) used on Master button triggered Slave on Click then again at end of Play Delay  
Once [Play Delay](#) option was disabled in session there was no method of re-enabling
- v0.96** 01/12/10  
[Stop on MouseUp](#) option in Button Menu  
[Stop Page on Play](#) option in Button Menu  
Trim page bargraphs now respond to pan setting  
Palette selection added to [Output colours](#) dialog  
[Trackname font](#) can be set independently on each button  
Option to indicate buttons that have been [played](#) since the session was loaded  
Default [Midi Out](#) Velocity/Volume was 64 now 127 (maximum)  
All Stop button indicates when escape pressed  
Button WAV files can be [copied to Windows Clipboard](#)  
5.1 surround sound [pan](#)  
[Expand](#) number of track channels

Save pages as [screen images](#) to bmp or jpg files  
[CD burner](#) utility for for \*.cda and \*.wav  
Replay [Gain Metadata](#) displayed  
[DTMF tone decoder](#)  
Option to [Burn Packages](#) to CD/DVD  
[MicroFades](#) for short FadeIn durations  
[Play Delay](#) extended to operate on buttons however they are triggered  
Session file font sizes corrupted by importing blocks based on a different font reference frame  
[Midi All Stop](#) command will stop all tracks not just those triggered from Midi  
Preferred [WAV file editor](#) saved in session file  
[Timecode Trigger list](#) added  
[MicroFades](#) for all FadeOut durations  
Play Delay added to [Paste Special](#)  
[Status](#) Primary buffer details shown in wrong order  
MultiChannel channel mask not reset when [changing outputs](#) causing channel order to be incorrect  
[Fine Trim of In Point](#) added to Trim In options  
[Hide all button text](#) option added to aid display of button images  
[Telephone effects](#) and filtered tracks loaded onto next available button take the original trim points  
[/HardwareMxr](#) switch added to force soundcard hardware mixer to on - defaults to off  
Mixdown of 5.1 tracks prior to [burning to CD](#)  
[Paste](#) from Windows Clipboard  
[Merge timecode](#) option not taking into account trimmed tracks  
[Output device order](#) checked against last run - outputs repatched if possible  
Option to save new output patching or treat it as temporary  
Latest version of [PackageConvertor](#) added at end of each package file - for future use  
24bit to 32bit conversion mono channel bug fixed  
Windows 64 bit check added to status window  
[New Session](#) now resets button colour and font sizes  
[5.1 mix down](#) coefficients changed to ITU standard  
Level options added to [timecode generator](#)  
[PlayDelay](#) limit increased to 999s and shown in main window status bar hint  
[PlayDelay](#) play button flash now on Trim and Audio windows  
"[Other pages playing](#)" now always shown on tabs  
Ctrl+F open/restore [SpotOnSearch](#)  
iXML [metadata](#) decoder  
[Play Stack](#) utility, Play group 24 fades out Play Stack tracks  
AC3 and DTS decoders added  
Load New Session on [startup](#) option  
[Utility filename clear](#) menu option added  
[Click Track](#) generator  
[CD Track ripping](#)  
Playlists reinserted to [merged timecode file](#)  
More metadata fields added to [Playout Logs](#)  
[CD Track details](#) lookup  
Option to draw [highlight](#) rectangle/corners on buttons playing  
[Button colour](#) on a per Genre basis  
BWA V Description field into [log](#) as Notes field  
I+O (In/Out) keyboard shortcuts in [Trim window](#)  
[Spacebar](#) in trim window toggles Play from In/Stop  
[Button Fx](#) being switched on after session load but no parameters set  
Sample frequency button highlight on shift right click [Play mode panel](#)  
PPM [level meters](#)

[Multichannel fine trim](#)

[Autoload](#) CD metadata

[Virtual Playlist segments](#)

[Play/Stop - Play/Menu](#) option now set by click on status panel

[Fine Trim](#) dialog features extended

Trap added for very [long path names](#) and filenames (not paths) truncated if too long

Fade out when [Speed](#) automatically slowed to zero improved

[Set PC clock](#) from external timecode

FTP client added to upload [debug logs](#) directly to web site

Trap to stop [NetworkMidiOut](#) being set when loading package onto another PC

[Midi Channel](#) selection now scrolls in loop and default is AnyChannel

Test to warn on [opening Audition>v1.x](#) whilst tracks playing

[Log Window](#) set to stay visible

[Ignore Emulated Devices](#) option added to cover use of WAVE/WDM Combo sound card drivers

Number of channels button highlight on control right click [Play mode panel](#)

Popup hints for long text added to [Payout](#), [Event](#) and [UDPScan](#) grids

@ Loop command added to [CUES](#) message options

\$01 option added to [LIST](#) message to return numbers of tracks playing

[Cascade Links](#) Admin option to allow slaves to trigger masters

[LinkDrag](#) now resets link to be Play/Stop cancelling any existing VO/Pause/Pan

Play Slaves now permitted in [Groups](#)

Page Change UDP message being sent with [MidiOut Off](#) now fixed

[Output Patching/Masking](#) now covers 256 devices, **Masking for outputs>16 will need to be reset**

[LeftToBoth](#) and [RightToBoth](#) properties swapped so not saved correctly in sessions

[LeftToBoth](#) and other mixdown options added to [Render to New File](#) option

[Global properties](#) page 4 set to reorder output devices

Multichannel files that [failed to load](#) into stereo version now listed in dialog

Fast IIR filters added to [Effects](#) window (44k/48k only)

Button gain setting shown in popup hint and [status bar](#)

[Timecode Chase](#) of [AutoPlay](#) buttons to external timecode

[Timecode file generator](#) sample rate now 48000Hz was 44100Hz

Timecode [Biphase correction](#) option

[Midi Out devices](#) not loaded correctly from sessions built with v0.951 and earlier

[Click track](#) BPM resolution extended

[Global level meters](#)

PanL/PanR added to [status bar hint](#)

[Status bar](#) shows timecode in magenta if chase enabled

Option to clear Editor/Search/CD Burner utilities on cancelling [selection dialog](#)

[Render Trimmed track](#) to file fixed

[Highlight of bit depth](#)

[Midi assignments](#) not showing correct channel number when starting from 'Any'

[Midi loopback status](#) shown in lower case instead of italics conflicting with UDP Midi

SMPTE TC on/off option added to [Int/Ext dialog](#) with warning label if disabled

Web [version check](#) every 7 days

MIDI files can now be [loaded](#) onto buttons

[Advanced Editing](#) option moved to Options menu from Engineering menu

[Repatching](#) of multichannel tracks

Delayed [start time](#) for Play Stack

[Render file](#) fade law taking original button setting not current setting

[Force GPI Poll Check](#) moved into Admin|Misc menu

[Global Properties](#) default values changed

[Menu item locator](#) added

[Remote support](#) option added to Help menu

Midi [Note Out](#) on button stop  
[Timecode Triggers](#) trigger time window changed

v0.952 19/02/08

Trim window [find start of audio](#), default level -40dB with Options menu user setting  
UDP/TCP command [NOTE](#) added to list Midi notes allocated to buttons  
[PBus](#) control added, GPI In status panel shows underline when PBus control selected  
Shift right-click on GPI In panel toggles PBus control on/off  
[Multiple files](#) loaded onto a range of buttons now sorted alphabetically before loading  
[AutoPlay](#) WAV preview now plays on Preview output  
Spectrum analysis ([FFT](#)) routine added to Trim window  
Internet Explorer version detection now recognises v7.0  
Trim window [find end of audio](#), default -40dB with Options menu user setting  
[Top+Tail](#) track added to TrimIn menu  
[Pause Masters](#) added  
[Play to In Point](#) facility added to Trim window  
Bug fixed that caused Trim In/Out timecodes to add 1 frame when popups were accessed  
SpotOn\_DLL added to package  
[UDP/TCP](#) Midi Note reply forced to be zero based channel numbering  
[AltAppDataDir](#) command line switch added  
[SMPTE timecode GPI emulation](#) option  
Error in saving value of Pan set in GainPan window fixed  
Option to colour buttons on a [per output](#) basis added  
Stop slaves now allowed in groups  
File read only access trapped in session and package save routines  
New folder for replacement wav file now saved in Locate File utility  
[Double-click](#) track in SpotOnSearch to play out via SpotOn preview output  
[Double-Click](#) track in Search window to play out via preview output  
Matt Nicholls bug fixed - button losing attributes when output changed via right-click popup  
Bug fixed that falsely triggered grouped PlayNext target when another grouped button played  
Option to use [Scroll Lock](#) to focus application main window  
[Default Tab name](#) option added to main window tab popup  
Double-click on a blank button brings up load dialog  
Alt+double-click on a blank button brings up Top/Tail load dialog  
Alt+drag+drop from Windows Explorer Top/Tails track  
Alt+drag+drop from search window will Top/Tail track  
[Export](#) WAV files now has option to restrict range to buttons on the current page  
Default [Search Utility](#) now set to SpotOnSearch  
GPI assigned to a button now moved with button on cut and paste  
Packages contain file format version now checked in [package load](#) for compatibility  
[Midi Out over Network](#) implemented for UDP  
Midi SetUp dialog has [Midi Out over Network](#) enable checkbox  
MidiOut status panel underlined when [Network Midi Out](#) selected  
Help file now called directly allowing clean switching between SpotOn and the help file  
Midi Out Auto fill added to [Paste Special](#)  
"^" added to Midi [CUES](#) command list to stop page  
[Left/Right to Both](#), Mono and channel phase inversion options added  
For 5.1 a [mix down](#) to stereo replaces the Mono option  
Option to [lock Session files](#) by setting them to be Read-Only  
Popup on playlist entry now has [cue to In](#) option if Playlist is disabled  
Velocity data added to [Midi Monitor](#) listing

Stereo and MultiChannel [bargraphs](#) added to Trim window  
Level [bargraphs](#) have A/B and M/S modes and LED style display  
Resolution of [level graph](#) improved  
Multiple [Midi Out](#) destinations now available  
MP3 Decoding timeout period increased to use 30s as default  
[Timecode format](#) options added to GPI setup window  
Trim waveform cursor positional accuracy improved  
FLAC (Free Lossless Audio Codec) and Ogg [decoders](#) added  
DirectShow Filter [property editor](#)  
[Remote Trigger](#) graphic added to button  
Shift+right-click on GPI In panel displays [nudge](#) popup to set GPI Ext timecode trigger  
Ctrl+Shift+Left mouse down on active Master or Slave shows [linked buttons](#)  
Ctrl+Shift+Left mouse drag/drop from active button will set/remove up a new [Play slave link](#)  
Audio capture ([SMPTE timecode](#)) list limit of 15 devices removed  
[EdgedBtnText](#) now defaults to on  
LED [bargraph](#) style defaults to on  
[SpotOnSearch](#) forced to closing on exiting SpotOn  
When display set to 120dpi multi channel [bargraphs](#) corrupted  
Option for 'none' added to [Preview output assign](#)  
Output [friendly names](#) added to all windows when selected  
[NarrowTrack numbers](#) hard coded to true  
Floating [Position bars](#) added for ganged playout, position and size saved in session  
Spurious Save Session prompt when exiting fixed  
Skip PlayList item added to [GPI emulation](#) - replaces Pause on buttons with a PlayList  
Extended range of [default fade out](#) times  
[Paste Special](#) can be qualified by output assignment  
[Timecode Generator](#) utility added  
[Merged Timecode](#) files  
File copy option added to [Statistics](#) and [Display](#) dialogs  
[Button Audio Effects](#) (Echo/Flange)  
[Button Filters](#) (Telephone/Low Pass)  
[AutoArmed GPIs](#) defaults to on, individual GPI AutoArmed defaults to off

**v0.951** 18/06/2007

Registry fix for new security key (dongle) drivers  
AIFF file format and 24 bit WAV now supported

**v0.95** 01/06/2007

Row and column paged track number options  
Identical Play and Stop Midi notes now allowed  
If Midi play/stop note received when track playing it will stop track otherwise it will play track  
Display forced to top left of main monitor if screen size changed between sessions  
Preview track conflicts with cut/paste/swap/delete fixed  
AutoPlay added to Load track dialog  
Midi In/Out text on buttons and Paste Special dialog showing incorrect Midi Channel number

08/04/2007

Security key (dongle) drivers updated  
Paste Special - Loop and Stop All options added  
Trim Edit enter timecode font size increased

Loop mode can be changed to on whilst playing without stopping track  
Loop mode can be changed to off without stopping track, loop cancelled when track is stopped  
Button looped circle changed from dotted if loop set to off whilst playing  
Glits/BlitsM18 filename trapped as special file name and button gain forced to maximum  
StopAll and PlayNext modifiers now maintained if Cut+Pasted onto a blank button  
Soft Splash screen added as ini file option

#### v0.92

TCP interface added  
Step to next button highlight added  
Multi monitor form position saved when second monitor is on the RHS  
MP3 decoder timeout was fixed at 15s now saved to in SpotOn.Ini file for manual adjustment  
Floating Level bars added  
Prompt for alternative location for uncompressed files  
Use Friendly Names option not saved in Global Properties  
Debug options moved to disabled section of Admin menu  
Midi messages filtered to avoid duplicate actions  
FastMidiMute function added to UnMute/Mute track instead of Play/Stop  
Price Is Right Midi glitch fixed  
Vista OS detected and compatibility checked  
Multi-Monitor support for Right and Lower monitors  
Long device names trapped in Output device assign long hint added  
Remote and decompressed file location - option to maintain alternate location for duration of session  
Double click on unassigned button directly brings up Load dialog  
Midi channel numbering fixed as 1..16  
Auto Armed Midi timecode GPIs option

#### v0.91

Changes made to UDP Scan dialog  
Preview Track added  
LIST and CUES UDP commands added  
Wave and Master volume controls now trapped at >0.5dB from norm rather than absolute  
VolumeCheck now Admin menu option  
Location for saving remote files can now be selected per track defaults to Local File Folder  
Set from next MIDI input option added to Midi SetUp and GPIMidi SetUp  
x0 fade out glitch fixed  
Locate File deleting StopAll and Playlist entries  
Holding Shift+Alt in preparation for Track Pvw now shows left status panel yellow  
Button being previewed has outer cross hatch rectangle  
Payout logs now have output filtering  
Payout log shows aX, bX etc for missed durations  
Installation device order saved to ini file  
Set from next MIDI input option added to GPIMidi SetUp  
Win2000/WinXP timer bug fixed, Timer Adjust menu option added  
madException handler added  
Compressed debug files moved to Admin menu  
Max number of event/payout/exception logs increased to 90 days  
LimitLayout menu item hidden and forced to false

Step in gain level on fade out when Midi Velocity used with Stop Velocity>Start Velocity  
Modified loop count being remembered on Copy/Swap  
'-' removed from delimiter list in wordwrapping  
Pause/UnPause logic changed to Play/Pause/UnPause  
Preview mode Gain/Pan/Trim/Speed parameters added  
Tracknames page has button coloured blocks in front of track names  
Master/Slave summary 125..126 now reads 125,126

**v0.90** 28/07/2006

Button images saved into Packages  
GPI pause/unpause action added  
GPI range extended to 64  
Locate file now auto-fills on 'modify session and select next button'  
Web hyperlinks can be disabled via a menu option  
Button colour saved separately in Btn Image and non-Btn Image modes to improve readability  
Fade bug in trim window when centre-click cueing up and rehearsing out points  
Autoload button images option to associate button image with an audio file  
Button Regions introduced to manipulate rectangular regions of buttons  
Drag and drop bmp/jpg from Windows Explorer  
Wait box shown at start of search process whilst scanning links  
Ctrl+F shortcut to File search  
Btn popup position moved away from menu items avoid accidentally selecting Cut option  
Left click + spacebar emulates centre click when not in Step to Next (touchscreen pause)  
Global|Statistics offers facility to copy files from Local folder to a more relevant location  
Playout log selection save to file option incorporates a column filter  
Trimmed tracks can be rendered and saved as a new file

**v0.89**

Playout logs set to restart at midnight  
GPI device present test added to allow GPI device to be unplugged when SpotOn is running  
Compressed debug logs added to assist development  
Event and Playout log right-click save selection not saving the correct lines  
Free disc space check added to Package Save As  
Multiple track moves in TrackNames dialog enabled  
Search window list can be ordered order by alphanumeric or most recently used tracks  
Button Images can be loaded from \*.bmp and \*.jpg files  
Midi AllStop and AllNotesOff now only acts on buttons originally played via Midi note On  
Custom button colours saved into session file  
Pan position labelled 0..100  
GPIs can be emulated by Hotkeys  
WAV file load error caused by display field embedded in Audition 2.0 files now trapped

**v0.88**

Locate missing file action incorrectly reporting mismatched file timestamps  
Main window Tab text now takes '^' as embedded line break

Tabs text now split over 1,2 or 3 lines depending on tab height  
Package Viewer now lists session option settings  
Button track name text label now allows '&' character to be entered  
Fade in/out times extended to 15s  
Voice Over Gain adjustment now includes gain swell to +10dB  
Gain increase when fading out during an active Voice Over fixed  
Session, Package and Block file Save As action checked for incorrect file extensions  
PlayDelayed buttons not firing master/slaves - fixed  
Voice Over fade depth now has user defined option  
Fade In/Out times have user defined values  
Coarse gain display in Audio setup dialog added  
Midi monitor run/stop button text changed to be more obvious  
Audio Setup trim window slow to draw when fades exceeded clip length -fixed  
Paste Special Fade In/Out law checkboxes added and default to on when fade in/out checked  
MenuIcons option now defaults to true  
Global Properties dialog box added to access commonly used options  
Button track number color logic changed so that FadeOut takes preference over FadeIn  
Track gain handling changed to use separate levels for FadeIn, FadeOut, VOGain and Preset Gain  
VO gain not returning to original level  
Pan Masters added  
Volume not at zero warning dialog now only shows outputs that are enabled  
Output selection added to popup group menu as an option  
More exception events logged and untrapped application exception now reported  
Playout log durations now checked for previous 16 entries in case of very rapid restarting of tracks

#### v0.87

On refreshing tracks if track has a modified playlist, button playlist is updated  
SkipPlayNext option - track after the end of a PlayNext sequence is the next selected to play  
Playout log duration added to onscreen, disc and XML logs  
Popup menu added to Main Tabs to edit Tab names  
Selecting Browse to Folder in Properties dialog now closes dialog  
Page Stop very slow in responding when >40 buttons on a page - fixed  
Save prompt appearing when no changes had been made - fixed  
Date and time added to session/package viewer report  
Split monitor mode supported

#### v0.86

Buzzer timeout options changed to include a closer to infinite value actually 99 minutes  
Play trigger notes added to playout log e.g. 12h = button 12 played via a hotkey  
Duplicate Play log entry removed from Midi In triggers  
Audio Setup window triggered Midi Out when playing tracks - now inhibited  
Unassigned buttons do not now show the duration previously shown as 00:00  
2GB limit removed from dropped files  
Load package now includes automatic call to PackageConverter if Package version incorrect  
SpeedBar x0 button added  
File Not Found/Locate File options added  
Middle+Right Mouse button detected and calls right click menu, added as an option

Auto fill Midi notes auto incrementing all the time - fixed  
Countdown on buttons enabled via Show Elapsed Time option and Ctrl+T shortcut  
GPI SetUp window has shortcut of Ctrl+G  
Output Device Assign "Reset Order" action changed to delete infile o/p entries on save  
Playout logs not being saved on exit if <5min elapsed since last button played - fixed  
On refreshing tracks if track has a modified comment, button comments are updated  
Multiple lines allowed in comment field  
Recursive Invalid Date Encode error - fixed

**v0.85** 18/10/2005

Browse Folder option added to Display/Hotkey local filename right-click options  
WMA, MP2 and MPEG file decoding enabled  
UnPausing short tracks playing mute - fixed  
GPI stop action added  
Highlight of buttons on a specific output added  
StartUp message if audio output levels are not set to 0dB  
Volume menu moved to Engineering  
Default sample frequency changed to 48kHz  
Search window resizable  
Playout log file save conflict - fixed  
Updated security drivers incorporated  
Commented or Copyrighted WAV files are shown in blue text in search window  
Refresh Tracks resaves link with new attributes (comment/copyright)  
Paste special now has auto increment of midi in notes  
Buzzer group timeout count can be cleared by playing any button on Group 25  
Play group 25 is now shown as 25! in play group selection windows  
Buzzer timeout options changed to include an infinite (10m) value  
Switching GPI Off/On will clear Buzzer Timeout  
Session Analyser added

**v0.81**

XML version of Playout logs added  
Page Stop button added with menu option to show/not show  
Page tabs have two lines of non-intelligently word wrapped text on medium and large sized tabs  
Voice over depth range changed to have finer steps  
Ctrl+Right click brings up Hotkey selector, duplicate hotkeys automatically deleted  
Pressing DEL key in Hotkey selector accepted to delete current assignment  
Button GPI icons now switch with GPI enabled checkboxes  
JoyStickID defining GPI input saved per machine not per session, will ignore settings in any session loaded  
Audio window Playlist has Cue name column reduced to show more notes text  
Double-click on VO depth label resets VO level to default  
Locked Midi removed from swap, copy and paste operations  
Locked Hotkey removed from swap, copy and paste operations  
Package Converter now covers v80 and v81 files

**v0.80** 29/06/2005

Features:-

AdminPassword command line switch now shows both Engineering and Admin menus

at StartUp  
PlayNext locked to button  
Preparation (/Prep) mode added - 16 output devices in total and status bar shown in yellow  
WAV header test reports file details on unrecognised file types  
Midi Velocity=0 trapped to convert into Note Off if option selected  
Web link to release notes added  
User Forum added  
StopAllOnPlay locked to button  
Supported Modes analyser added  
Voice Over mode added to master/slave links  
File|New Session special file added ~NewSession.dta  
Speaker position in multi channel mode added to Audio window  
Output device assign can now set output speaker format  
Button highlight now shows MidiIn/HotKeys in yellow  
PlayDelay setting added to Gain Pan dialog  
Session load/save folder added to FileFolders dialog, option to force as default  
Dropped file list now sorted into alpha order  
HotKey and Midi button text black edged and drawn transparent  
Default WAV load folder now an option  
Broadcast WAV (BWF) added at end channel number label in audio dialog  
User friendly output names option added - only appear in GainPan dialog  
Auto-show of session notes with checkbox on dialog to disable for that session  
Output ident audio files added to Output Mask dialog  
Fade times can be set by dragging fade bars in trim window  
MP3 file details added to FilePreview dialog  
SpeedBar additional resolution on long speed bars and percent actual speed in title bar  
Overlapped Hotkeys can also be triggered by mouse left-click  
Broken links summary added to Master/Slave Links setup with option to delete all broken links  
Scope of Paste Special increased to include global, current page and button range  
Audio disc filenames can now be modified  
File export added  
Page Stop on Play option  
Output mask check box sense reversed to be selected instead of masked  
Output device letter added to playout log listing  
Statistics graphs for file size and session folder fragmentation  
Session and Package viewer incorporated  
Archive viewer for Playout and Event logs  
Ctrl+M shortcut for Master/Slave links setup page  
Windows set for operation in 120 DPI screen resolution  
PlayNext added to Paste Special options  
Package and session files can now be drag and dropped onto any SpotOn button  
Midi Note On at velocity zero conversion to Note Off made the default state  
Midi timecode shown in data rate panel when valid timecode detected  
On buttons containing a playlisted track the mouse middle-click will emulate ctrl+right click, so allowing a playlist item to be skipped without the need for a keyboard press  
SpotOn ScreenSaver added to installation

#### Fixes:-

Step to Next up/down not always updating status  
Save session prompt dialogs added and only shown when session data modified  
Mouse mode status panel not changing colour to blue when in debounce mode in XP  
Swap button not swapping output devices  
Save prompt shows on loading over blank session  
Button layer drawing order changed to stop loop erasing the HotKey/Midi legend  
Package loading confused by leading blank buttons  
GPI setup group boxes transparent in XP themes  
Advanced Edit reminder dialog only shows twice after being set true  
Repeated pressing of Grouped btn caused btn with long fades to have the fades restarted

XP ghosting fix applied  
Changing Fade out time in Audio dialog stopped track  
'Quatermass' bug  
Drag and Drop files not working on unassigned buttons  
MP3 silence bug  
Voice Over fade up step missing  
Search dialog causing error if opened repeatedly  
Session notes not displayed on loading package  
Package version check added to prevent packages being loaded by older versions of SpotOn

**v0.75** 23/01/2005

Play-click debounce added 0..250mS  
EnableSearchMenu, HintsOn, UseMenuIcons, UseUDPMidi now stored per session - will need to be reset after updating  
+ added to Midi in icon when both Play and Stop notes are assigned  
Button icons added over Hotkey/Midi text not underneath as before

v0.74

GPI display expanded to 16  
Now button added to GPI PC Clock time entry  
Unplugging GPI device stops polling until rescanned  
Rescan of GPI devices added to GPI setup window  
Prompt dialog added to load package sequence asking to save extracted session as new session  
GPI icon diamonds have + in centre if more than one GPI assigned to button  
Session/Package version numbers added to event log  
NumLock on option in engineering menu  
HotKey summary added for alpha/qwerty and numeric  
Tab height options renamed Small, Medium, Large  
Link number in Master/Slave dialog not selected on display - now selected

v0.73

Pause indicated by dashed square on button  
Folder locations added to Status window  
Option to skip muted buttons on step to next  
Centre mouse button pauses track if option selected  
Midi over UDP rejecting some Midi note combinations - fixed

v0.72

GPI triggering from PC clock and Midi timecode  
Loopback Midi enabled with Midi In On  
Recent Session/Package list not reading first item fixed  
Scroll wheel disabled on floating speed bar  
Master/Slave dialog opens with first unused link selected  
Play next now triggers Master/Slaves functions previously disabled in v0.45  
Master link allowed on Grouped button  
Button number label width increased to include Master/Slave/Group indicators  
Step to Next skipping over muted buttons removed  
Status bar text shows Midi out in italics when loopback enabled  
ShadedButtons property replaced by (edgewidth>0)

v0.71

Audio output level settings shown in SetUp menu  
Blank buttons ignored in Step To Next mode  
Delete HotKey Duplicates option added  
Sound mixer mute/gain settings added to SetUp menu  
Duplicate destination filenames extracted from package trapped  
Page layout extended to 16 columns x 10 rows, was 10 x 8  
Hotkey paged mode not working on button 1  
Advanced Editing option added allowing direct editing of files  
No fade out on short clips had disabled Play Next fixed  
Ctrl+R shortcut to Refresh tracks  
Lock colour to button in Properties dialog  
Page 1 selected when new session loaded  
Full playlist enabled when refreshing a track that did not have a playlist but now does  
Hotkey and Midi In text available simultaneously if both present Hotkey takes preference  
GPI Pause and UnPause added  
Midi GPI emulation of GPI instead of just "Step to Next"  
Stop on GPI Off removed from acting on Un/Pause command  
Link slaves stopping when master button stopped manually fixed  
Midi Loopback added looping outgoing midi message directly to input  
GPI In can be enabled when no JoyStick selected  
GPI status panel colour still brown when no JoyStick selected but can be activated  
Master/Slave Play and Stop ticks not mutually exclusive  
Links Play/Stop entries now show red cross when group selected  
Links can be sorted in master button order  
NumLock state not set on start up  
Warning message added when Try Remote Filename option selected  
File menu session/package file entries masked with Try Remote Filename  
Button time @ prefix now responds to floating speed bar settings  
MouseWheel activated on floating SpeedBar  
Fill run of buttons with same file  
Clear Session and Package history lists  
Pause in Playlists inhibited

**v0.70** 17/11/2004

Session Notes added to Info menu  
Start with blank session moved to Options menu

v0.69

Fade out disabled on short clips (<1s)  
Rehearsal of last xx seconds added to trim window  
Status bar height adjustable via Display menu  
Out point rehearsal now available from Trim window

v0.68

HotKeys now not included in Button "Swap" function if either button has the HotKey Locked  
Menu option to restore session from BackUp files  
Main menu item Search can be disabled in Options menu  
File timestamps set to use UTC instead of local time

v0.67

Short items at beginning of playlist do not loop automatically  
Temporary changes to playlist loop counts allowed

v0.66

abc.MP3 load overwriting existing abc.WAV unique filename now used  
Full playlist now not inherited during copy when copied file had been edited and had no playlist  
\*.MP3 copies now stored in "Local" files folder

**v0.65** 10/10/2004

Save As updates title bar filename  
File timestamp trapped when reloading buttons with same filename  
Functions (Hotkeys/Links/Midi...) that are disabled now shown in function setup dialog  
Midi In Play/Stop now have separate selectors  
Message boxes in loading of Mini Packages clarified

v0.64

BackUp and Playout log file locations now user defined  
WAV file preview added to Load dialog  
Shift+Ctrl+right-click now shows popup group selection

v0.63

2GB limit in Package load/save progress windows removed  
Destination button color retained on copy  
Destination button output device retained on copy  
Variable speed range increased 1%..400%  
Minimum variable speed now engineering option  
Playlist viewer columns resizable  
Gain Pan timecode shows ~~:xx:xx on tracks longer than 1 minute

v0.62

Internal change to stop very short clips inadvertently looping  
Option to load a blank session on start up added  
Page tab height adjustable to ease use on touchscreens

v0.61

Skip playlist item improved  
Button Color retained on load

**v0.60** 18/07/2004

Menu Icons  
Settings saved across multiple user LogOns

v0.59

Output Assignment scope now selectable  
Play Groups available increased to 25

v0.58

Diagnostic Web Server  
Output port mapping

Status window resizable  
Midi timestamp in playout logs

v0.57

Buffer initialised with silence  
Buzzer Groups added

v0.56

Midi alternative to hotkey button text  
Midi/Hotkey overlapped modes separated  
MidiIn in italics if Midi over UDP is enabled  
Log file page rewritten with circular buffer  
CueUp centre click copied to shift+(left or right) click  
Recent Session and Package lists  
Ganged and Paged options for Midi In and HotKeys

**v0.55** 12/04/2004

Output device retained when loading clip onto active button  
Form caption indicates when file is saved to disk  
Copyright field added to play log  
Overlapped mode extended to Midi In  
Midi In to Out copy added  
Drag and drop between pages  
Output device masking  
Midi over UDP  
Midi all notes stop  
Midi monitoring dialog  
Log fade now default

**v0.50** 09/03/2004

Source code recompiled with D7 compiler

v0.46

Primary mixer sample rate selectable 44.1/48kHz  
Floating speed bar added  
Global output assignments now selectable

**v0.45** 24/02/2004

Internal changes to minimize CPU usage.  
Play next no longer triggers Master/Slaves functions  
Button highlight of Links, GPIs, MidiIn, MidiOut, Hotkeys

v0.44

Stop all on play code changed to avoid delaying play action  
Button Play/Stop groups added

v0.43

Button panel tab draw routine changed

v0.42

File Folders dialog text changed  
Editor filename in packages ignored  
Joystick BaseIndex added  
Data load/save folder saved on exit  
Package load/save rewritten

**v0.40** 10/02/2004

Save on exit prompt dialogs added  
Midi emulation of GPI "Step to Next"  
Midi In selection now a multi select check list  
Midi Out selection now single select check list  
Option to send an all Midi notes off message on All Stop  
Speed control labelling shows absolute speed  
Speed control range increased now 25%..400%  
Menu settings added to log file  
Invalid audio port GUIDs removed when reading from package  
Audio port GUIDs and DeviceIDs compared on changing  
Button colour retained when changing output device  
Unused package media folders now deleted  
Package Media root folder added to File Folders options  
Package load sets text attributes on all buttons  
Single hotkey repeat works in Overlapped mode  
Loading of MP3 files  
Invalid file format exceptions trapped  
Log load failures due to invalid file formats  
Timestamped play list created  
Button panel tab text auto-sized  
Try Remote Filename now defaults to false on startup  
Remote filename links only enabled by Try Remote Filename  
Sticky Master/Slave links modified  
Midi In indication on unassigned button removed  
Failed to find file on playout dialog added  
Only one instance of application allowed  
Partial packages implemented

**v0.30** 28/01/2004

Activity log file added  
BackUp file suffix retained on exit  
Loading Button group now reports missing files  
ReEntrant Undo actions trapped  
Internal button patching disabled  
Duplicate files removed from packages  
Search facility includes remote file locations  
Splash screen added

v0.21 Screen redraw flash removed when toggling status bar options  
Overlapped HotKeys run even if inactive buttons have duplicate HotKeys

**v0.20** 19/01/2004

Internal change - ManualStop tag set in AllStop mode

v0.19 Track load has the option to search both local and remote file locations  
Undo added to merging of button groups

Overlapped indication on Status Bar only present with duplicate HotKeys

v0.18 Hints and help file updated  
Screen drawing speed improved  
Master/Slave attributes remain with button unless moved or cleared

v0.17 Number of Master/Slave links increased

v0.16 Optimize Tracks now has global and current page options.  
GPIs can "Home" the step to next facility.  
Ganged and Overlapped hotkey modes added.  
HotKeys now not case sensitive.  
HotKey on/off toggle added to status bar.  
Blind buttons disabled.  
Primary Sound Driver output removed from selections  
First named audio output is now designated A.  
Bugs with very long playlist and invalid playlist data trapped

**v0.15** 20/12/2003

First release